

# FURUNO

# OPERATOR'S MANUAL

## Radio Rack Console

MODEL RC-1500-1T

There are two versions of the radio rack console: standard type and the dual Inmarsat C type which has two Inmarsat C systems.

For the dual Inmarsat C type, skip the chapter on NBDP.



**FURUNO ELECTRIC CO., LTD.**  
NISHINOMIYA, JAPAN

© **FURUNO ELECTRIC CO., LTD.**

9-52 Ashihara-cho,  
Nishinomiya, Japan

Telephone : 0798-65-2111

Telefax : 0798-65-4200

Your Local Agent/Dealer

All rights reserved.

Printed in Japan

PUB.No. OME-55970

( TENI ) RC-1500-1T

FIRST EDITION : JAN. 1995

H : APR. 16,2002



\* 0 0 0 8 0 6 2 5 9 0 0 \*



\* O M E 5 5 9 7 0 H 0 0 \*



# SAFETY INSTRUCTIONS

"**DANGER**", "**WARNING**" and "**CAUTION**" notices appear throughout this manual. It is the responsibility of the operator of the equipment to read, understand and follow these notices. If you have any questions regarding these safety instructions, please contact a FURUNO agent or dealer.



**DANGER**

This notice indicates a potentially hazardous situation which, if not avoided, will result in death or serious injury.



**WARNING**

This notice indicates a potentially hazardous situation which, if not avoided, could result in death or serious injury.



**CAUTION**

This notice indicates a potentially hazardous situation which, if not avoided, could result in minor or moderate injury, or property damage.



# DANGER

**Never touch the SSB antenna, antenna coupler or lead-in insulator when the SSB radiotelephone is transmitting.**

High voltage which can cause death is present at the above-mentioned locations when the SSB radiotelephone is transmitting.

Turn off the power before performing maintenance on the SSB antenna.

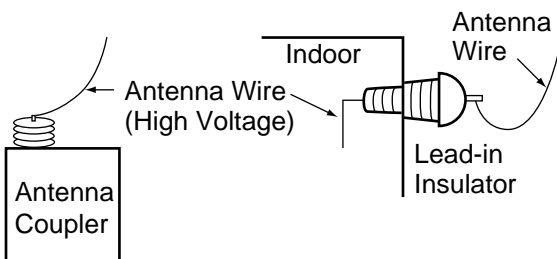

# WARNING



**Do not open the equipment.**

This equipment uses high voltage electricity which can shock, burn or cause serious injury. Only qualified personnel should work inside the equipment.

**Do not disassemble or modify the equipment.**

Fire, electrical shock or serious injury can result.

**Turn off the power immediately if water leaks into the equipment or the equipment is emitting smoke or fire.**

Continued use of the equipment can cause fire or electrical shock.

# TABLE OF CONTENTS

**Part 1 RC-1500-1T**

**Part 2 SSB Radiotelephone**

**Part 3 MF/HF DSC**

**Part 4 NBDP**

**Note:** NBDP is not included in the dual Inmarsat C type radio rack console.

**Part 5 Inmarsat C**

**SPECIFICATIONS**

This page is intentionally left blank.

***RC-1500-1T***

---

***Part***

**1**

# TABLE OF CONTENTS

## Chapter 1 INTRODUCTION

1.1 System Diagram .....	1-1
1.2 Equipment Description .....	1-3
1.3 Mutual Operation of Equipment .....	1-4
1.4 Power On/Off .....	1-5

## Chapter 2 RC-1500-1T Control Panel and PP-510

2.1 RC-1500-1T Control Panel .....	2-1
2.2 Maintenance .....	2-4
2.3 PP-510 .....	2-5



# Chapter 1 INTRODUCTION

## 1.1 System Diagram

The figure below shows the system diagram for the RC-1500-1T. Equipment are controlled using FURUNO's own radio interface system called MIF (see note below).

**The type and number of the component differ from set to set.**

**Note:** MIF is a handshaking type signal exchange system developed by FURUNO for remote control of our radio equipment. In the RC-1500-1T, for example, the DSC-60 can automatically set the frequency on the FURUNO SSB Radiotelephone.

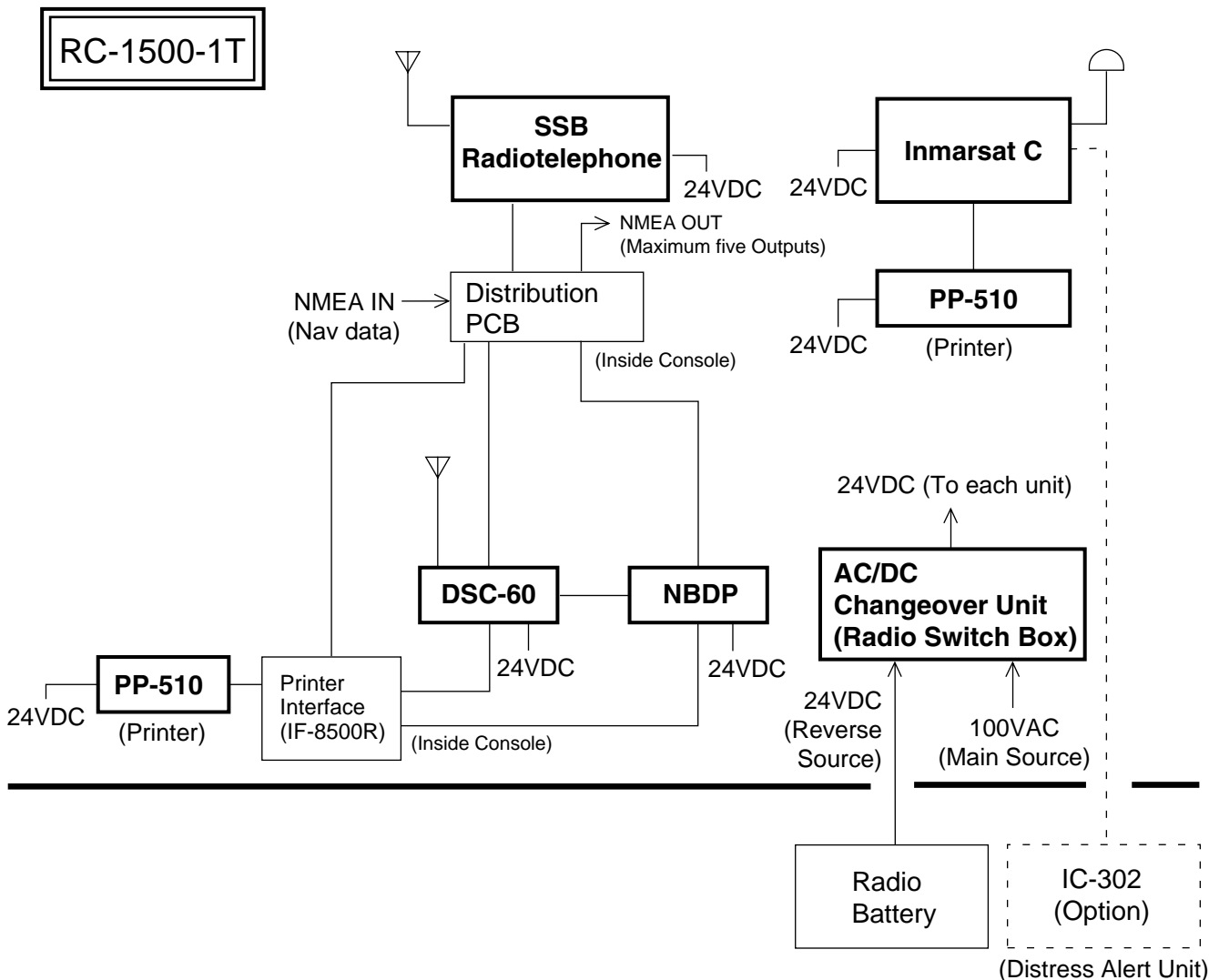

*System 1 Standard type*

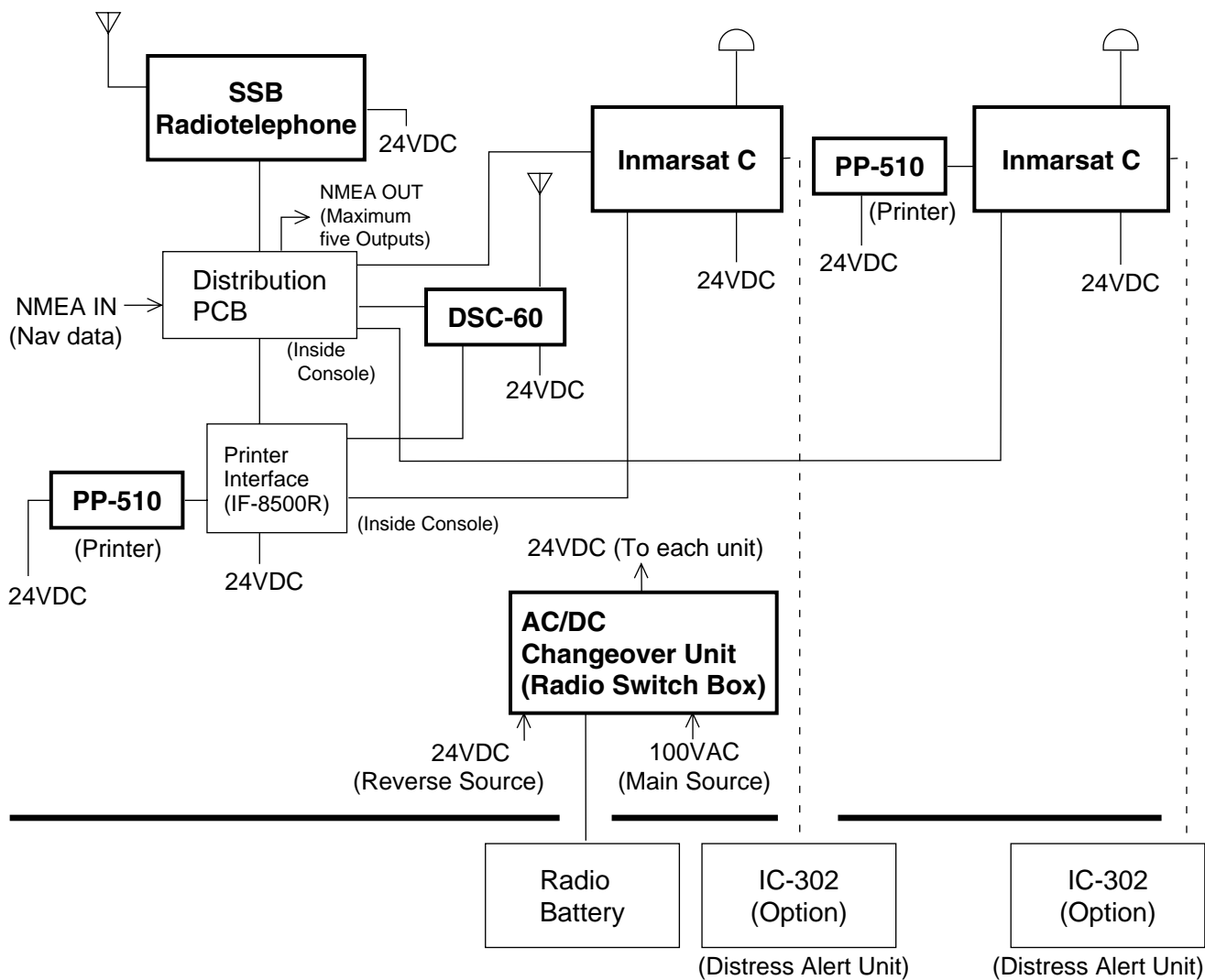

*System 2 Dual Inmarsat C type*

## 1.2 Equipment Description

Keep the all equipment powered while the vessel is underway by regulations.

### FURUNO SSB Radiotelephone

For ship-ship and ship-station radio communications in the MF/HF band. The main communications modes used are;

- Voice communications (J3E/H3E) via the handset
- DSC communications (Telex) by the DSC-60
- Telex communications by the DP-6

### DSC-60 MF/HF DSC Terminal

The DSC-60 has many functions. Below are its main functions.

- Distress alert: Transmit the distress alert via the FURUNO SSB Radiotelephone.
- Watches DSC distress and safety frequencies. The DSC-60 receives distress alert from vessel in distress and all ships call (safety and urgent call) from ship or coast station.
- All Ships Call: For urgent situation on own ship (for example, request for medical assistance).
- Individual Call: Place a call to a specific ship or coast station.

### NBDP Terminal

The DP-6 provides Telex communications with coast stations over the MF/HF band via the FURUNO SSB Radiotelephone. Furthermore, it can receive MSI (Maritime Safety Information) messages via the FURUNO SSB Radiotelephone (Scan reception).

**Note:** NBDP is not included in the dual Inmarsat C type radio rack console.

### Inmarsat C Mobile Earth Station

Provides distress and general Telex communications for mobile and fixed terrestrial subscribers in the Inmarsat C communications network. Telex messages are processed by what is known as store-and-forward Telex. A Telex message transmitted by you arrives at a coast station where it is stored temporarily and then delivered to the subscriber specified (No full duplex communications possible.)

### AC/DC Radio Switch Box

The AC/DC Radio Switch Box consists of a battery charger and two rectifiers (PR-850AR and PR-300) which can accept both AC and DC powers. In the event of main AC power failure, auxiliary power (battery) provides power to the equipment, for the amount of time stipulated by radio regulations.

## 1.3 Mutual Operation of Equipment

As noted earlier, the equipment in this radio console are interfaced by FURUNO's MIF radio interface. For example, to transmit a message over the DSC-60 or DP-6, the Tx and Rx frequencies and class of emission are automatically set on the FURUNO SSB Radiotelephone and then the message is transmitted.

Two printers are supplied and one is dedicated to the Inmarsat C. The other printer is for both the DSC-60 and DP-6. If the DP-6 is used (message transmission or reception), this printer is automatically connected to the DP-6 to print out the data. When the printer selector switch in the console is set to the "AUTO" position, it automatically connects one of those equipment to the printer on a first-come-first-served basis. For example, if the DSC-60 is used (message transmission or reception), the printer selector switch automatically connects the printer to the DSC-60 and disconnects itself from other equipment.

### Connection between DSC-60 and DP-6

Suppose you transmitted a call over the DSC-60 and want to communicate with the receiving station by the DP-6 instead of FURUNO SSB Radiotelephone. If the DSC-60 and DP-6 were not connected you would have to set the several data such as working frequency, communication mode, etc. manually on the DP-6. Because they are connected by the remote function, however, the data mentioned above are automatically set on the DP-6 via the DSC-60.

# 1.4 Power On/Off

## Turning on the system

1. Turn on breakers and switches on the AC/DC Radio Switch Box in the following order:
  - ① 100 VAC main power switch
  - ② PR-850AR AC input breaker
  - ③ PR-850AR DC output breaker
  - ④ All toggle switches (any order) on right side
2. Turn on power switches (any order) of all equipment in the console.

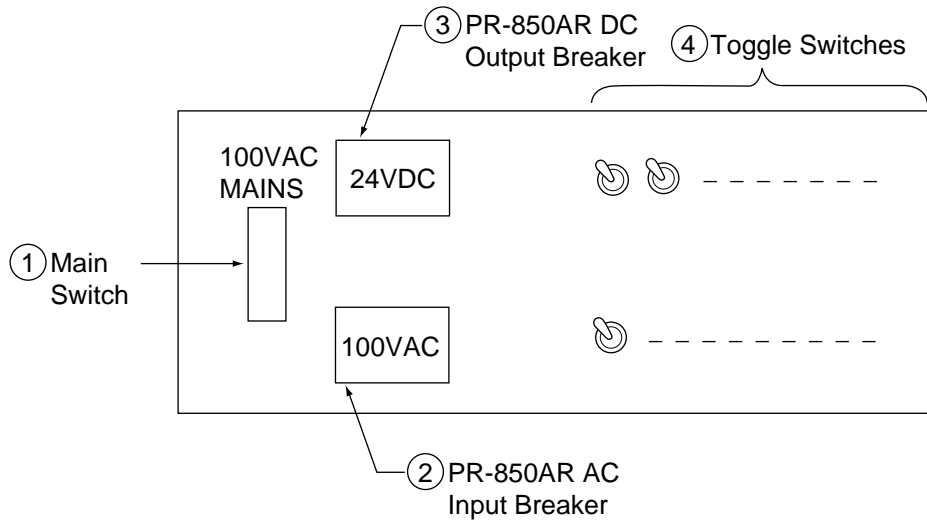

## Turning off the system

Reverse the order shown above.

(Reference)

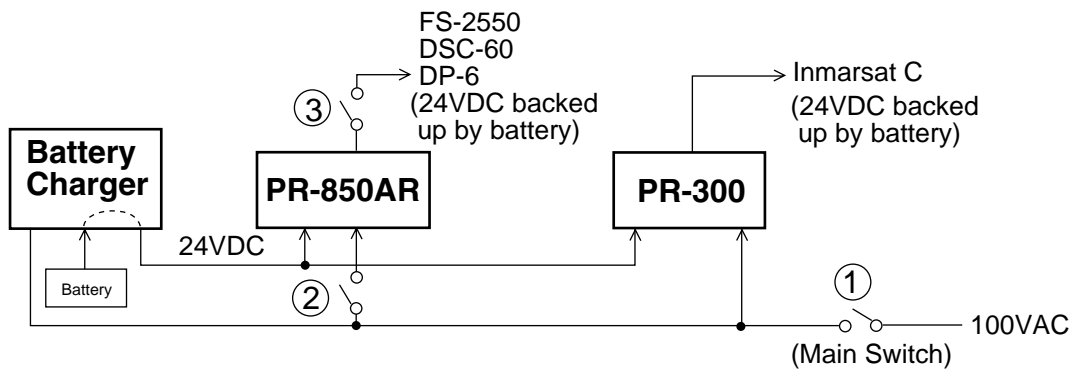

This page is intentionally left blank.

# Chapter 2 RC-1500-1T Control Panel and PP-510

## 2.1 RC-1500-1T Control Panel

The figure which follows is an exploded view of the control panel.

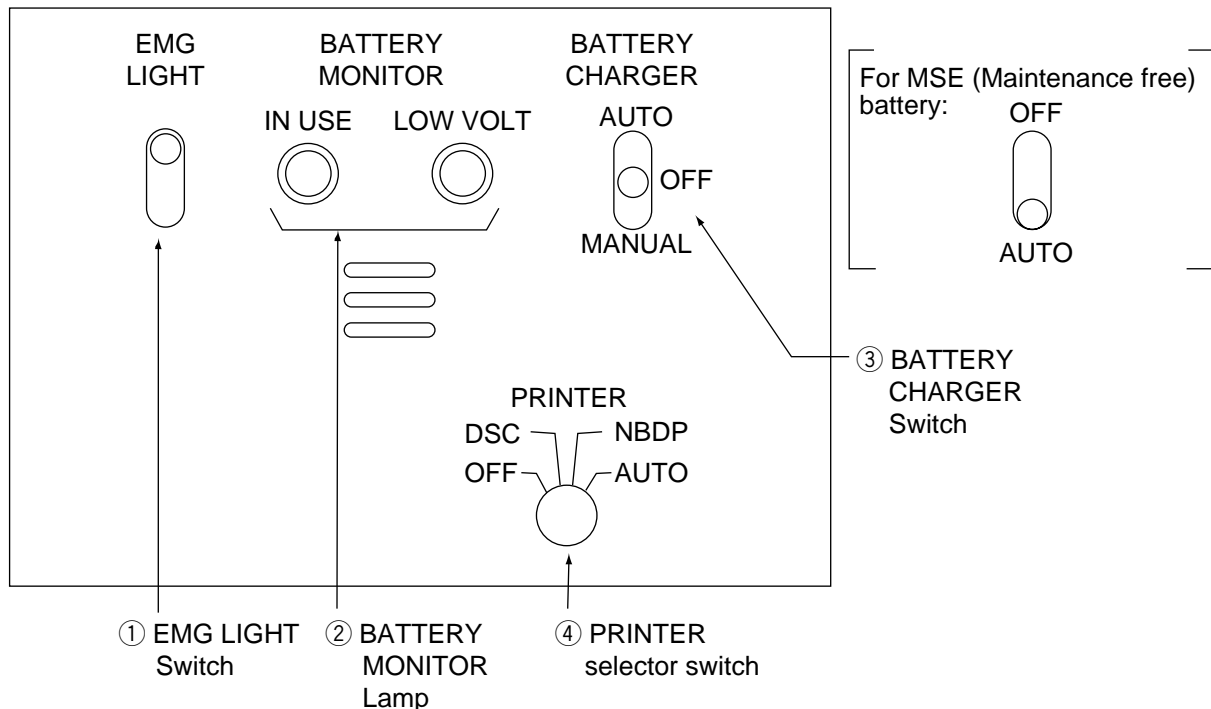

### Control description

#### ① EMG LIGHT switch

Turns the emergency lamps at the top of the console and external lamps (if applicable) on/off. If an external emergency light switch is provided (at the entrance of the radio room), the emergency lamps can also be switched on/off by this switch. (Flipping the switch up or down changes the state of the lamps; upward position is not always on.) The emergency lamps can be turned on at any time regardless of AC power status.

#### ② BATTERY MONITOR lamp

IN USE lamp (AC power failure: orange): Lights to alert that the AC power has failed and radio equipment are being powered by the radio battery (DC power) alone. When lit, only the equipment related to distress communications are powered. (Power is not supplied to PP-510 or console lights.)

LOW VOLT lamp (low battery voltage: red): Lights to alert that the battery voltage is below 22.5 VDC. (Aural alarm sounds until the voltage becomes 22.5 VDC.)

### ③ BATTERY CHARGER switch

Turns battery charger on/off. When charging, battery voltage is shown on the voltage meter on the AC/DC Radio Switch Box (in the lower-half side of the rack console).

**AUTO:** Automatically turns on the battery charger when the battery voltage is below 24 VDC and turns it off when the voltage exceeds 27.5 VDC. While the vessel is underway, set the switch in this position.

**OFF:** Disconnects the charger from the radio battery.

**MANUAL:** Charge the battery manually. When the voltage becomes 28 VDC change the switch to the "OFF" or "AUTO" position.

For maintenance free battery, keep the switch to the "AUTO" position to maintain the battery voltage between 25 V to 27 VDC.

### ④ PRINTER selector switch

Selects the input source equipment for the printer mounted on left of the radio console.

**OFF:** Printer is not connected.

**DSC:** Connects the printer to the DSC terminal.

**NBDP**

**(INMARSAT) :** Connects the printer to the NBDP terminal.

**Note:** Connects the printer to the Inmarsat C for the dual Inmarsat C type radio rack console.

**AUTO:** Connects the printer automatically.

For general telex communications, set the switch to NBDP position. You may select the DSC position to log communications made on DSC terminal, or to print out the DSC's internal settings.

*Do not turn the switch while printing. Garbled printout will result.*



## Battery charging

Before operating the radio, check the battery voltage on the meter provided on the AC/DC Radio Switch Box. The battery voltage is maintained between 24 VDC and 27.5 VDC when the BATTERY CHARGER switch is in the AUTO position. Note that the OFF position of the BATTERY CHARGER switch may allow the voltage to drop below 24 VDC. In this case, charge the battery as follows:

1. Set the BATTERY CHARGER switch for MANUAL. Watch the charging current at the AC/DC Radio Switch Box. (For a 200AH battery, the charging current will be around 20A at the start, and will be reduced gradually as charging proceeds.) -----> For maintenance free battery, set the BATTERY CHARGER switch for AUTO.
2. Turn the BATTERY CHARGER switch off or set it to AUTO when the charging current falls below 2A.

**Note:** If the AC power has failed, the radio battery automatically supplies power to the radio equipment regardless of BATTERY CHARGER switch position. The battery will not discharge as long as the AC power is alive.

## Care of the lead-acid battery

The lead-acid battery powers distress-related communications equipment when the ship's main power and emergency power fail, to enable communications in the event of distress. Therefore, follow the points mentioned below to keep the battery in good working order.

 <b>WARNING</b>	
<b>Keep sparks and lit smoking materials away from the lead-acid battery. Make sure the battery room is well ventilated.</b>	The battery emits hydrogen gas which can cause explosion.
<b>The electrolyte in the lead-acid battery contains sulfuric acid which can be harmful, particularly to the eyes.</b>	If sulfuric acid contacts eyes, skin or clothing, flush directly with water. For eyes, contact a physician. Loss of eyesight can result.
<b>The temperature of the electrolyte in the lead-acid battery should not exceed 45°C.</b>	The electrolyte can cause explosion if it becomes too hot.

## **1. Confirming charging**

Confirm that the BATTERY CHARGER switch on the control panel is set for AUTO. Further, confirm that the battery voltage meter on the AC/DC Radio Switch Box reads between 24 V and 27.5 VDC.

## **2. Checking specific gravity of electrolyte**

The specific gravity of electrolyte is normal if it is  $1.240 \pm 0.010$  (at 20°C).

## **3. Water supply**

The electrolyte level can be seen on the battery. When the electrolyte falls below the highest graduation on the scale, fill to highest graduation with distilled water. Do not use diluted sulfuric acid or ordinary tap water—they will shorten battery life.

## **4. Cleaning**

The battery and the area around it should always be clean and dry. Clean the battery case with a water-moistened cloth. Do not use chemical cleaners to clean the battery; they may crack the case. Kerosene may be used.

## **5. Environmental conditions**

- Keep the battery out of direct sunlight.
- Coat the nuts and bolts which secure the battery contacts with anticorrosive paint for the lead-acid battery. Check yearly that bolts are securely fastened. Tighten nuts and bolts if necessary.

# **2.2 Maintenance**

## **1. Cleaning display screens**

Dust or dirt on the display screens of equipment may be removed with a soft cloth. Do not use chemical cleaners—they may remove paint and markings.

## **2. Cleaning floppy disk drives**

The heads in the floppy disk drive of the DP-6 and FELCOM 12 should be cleaned regularly to prevent damage to floppy disks. Use a floppy disk cleaning kit. (FURUNO can supply a floppy disk cleaning kit. It is type MCD-2, code no. 000-116-420.)

### Procedure

1. Insert a floppy disk cleaning kit in the drive.
2. Execute "Format" operation (in the  $\overline{\text{F1}}$  menu). The access lamp on the drive lights.
3. Wait until the access lamp goes off. Remove the disk. (Error message for formatting appears on the screen.)

## 2.3 PP-510

### Turning on the power

Turn on the POWER switch at the front of the printer. The POWER and ON LINE lamps light. The printer is now ready to print. If the ON LINE lamp is off, press the ON LINE switch to turn it on; you cannot print when the ON LINE lamp is off.

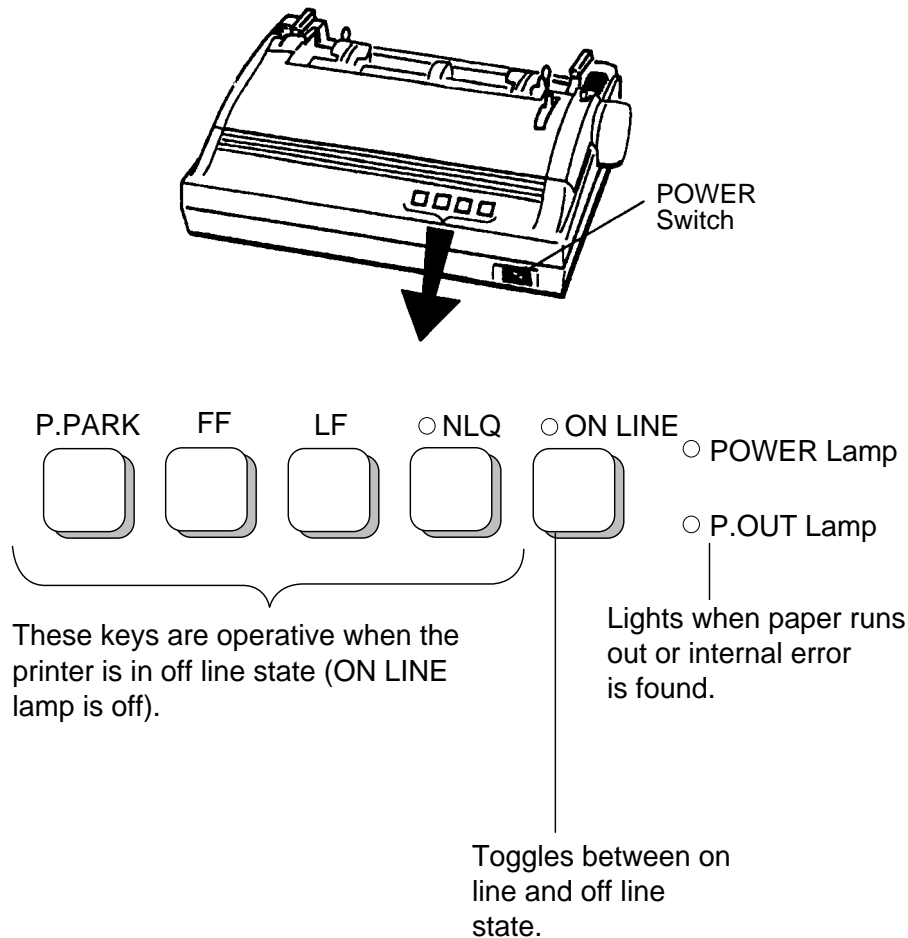

### Key description

#### [NLQ] (Near Letter Quality) key

Toggles between draft and NLQ print modes. Lighting the key selects near letter quality (high quality) print.

#### [LF] key

Advances the paper one line. Press and hold down the key to advance the paper continuously.

#### [FF] key

Advances the paper to the top of the next available form. The default form length is 11 inches.

## [P.PARK] key

Backs the paper by maximum 18 inches. If the paper is not detected after backing it, the P. OUT lamp blinks three times and the printer stays in off line state.

## Loading roll paper



This section shows you to load the roll paper.

Observe the following cautions when loading the paper:

- To prevent paper skewing or jamming, be sure the paper is positioned correctly.
- Never turn the platen knob too fast—gears may be damaged.

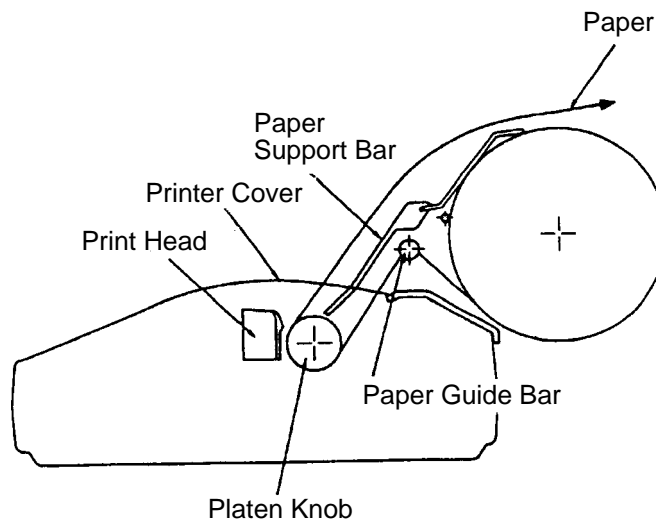

*PP-510, side view*

## Removing remaining paper

1. Press the  switch to back up the paper. Turn off the power.

- Unfasten screws (A) and push back (B) (for both right and left) shown below to remove the printer cover.

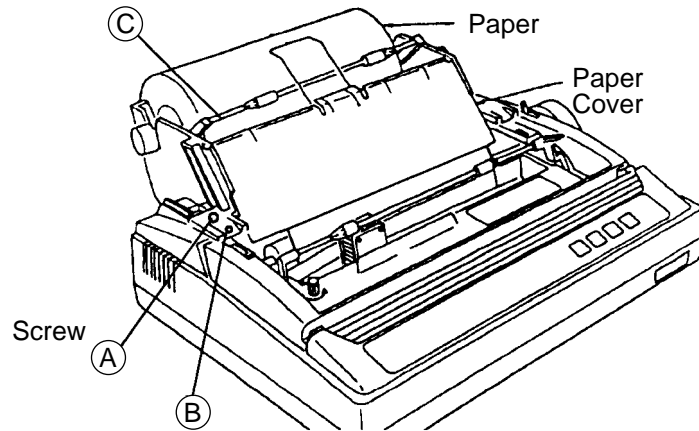

- Swing out the paper cover by 100° to 120° then lift it up from the right-hand side to remove it from the printer.
- Referring to the previous figure, lift the paper bail (C). As shown in the figure which follows, remove the roll paper stay (D) and then take out the roll paper.

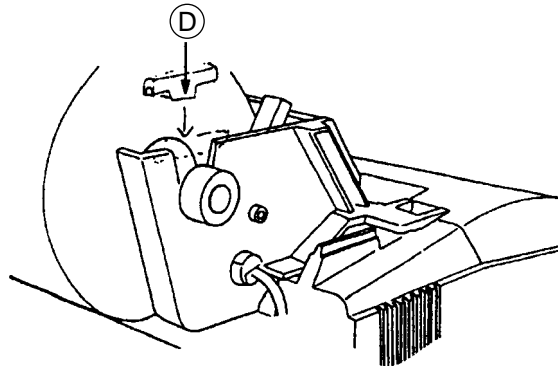

### Loading new roll paper

- Insert the roll bar into the roll paper from the left side. Set the roll paper to the roll paper cradle.

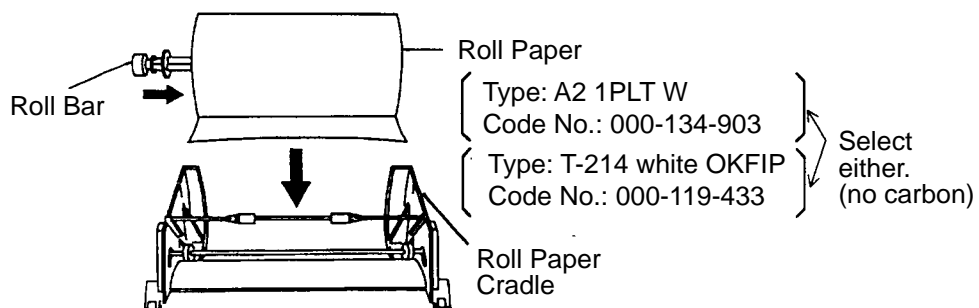

- Pull the paper bail toward the front. Manually feed the paper over the paper guide bar and under the platen. Turn the platen knob clockwise to feed the paper so it reaches the paper guide bar.

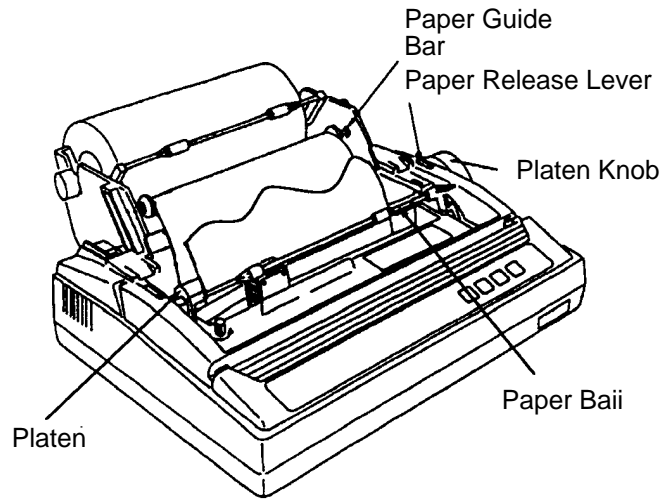

- Unlock the paper release lever to adjust the paper and then lock the paper release lever.
- Slide the left and right guide rings to position the paper straightly.

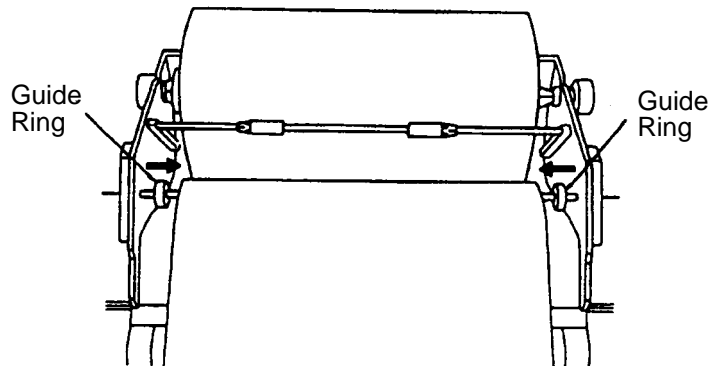

- Replace the paper cover, the printer cover and roll paper stay.

<u>Remarks on Replacement of Ribbon Cassette</u>		
Change the ribbon when print darkness is no longer suitable to your needs.		
Part	Type	Code No.
Ribbon Cassette	SP-16051NB	000-133-029
The print head is hot after printing. Allow it cool down before touching it.		

***SSB Radiotelephone***

---

***Part***

**2**

The RC-1500-1T can be connected to the FS-1562 series or FS-5000 series FURUNO SSB Radiotelephone. Refer to respective operator's manual for operating information.



***MF/HF DSC***

---

***Part***

# TABLE OF CONTENTS

---

<b>FOREWORD</b> .....	<b>vi</b>
<b>1. DSC SYSTEM OVERVIEW</b> .....	<b>1-1</b>
1.1 What is DSC?.....	1-1
1.2 DSC Call.....	1-1
1.2.1 Distress alert call and reply.....	1-3
1.2.2 Individual call.....	1-4
1.3 Audio Alarms.....	1-4
1.4 Remote Control and Automatic Acknowledge .....	1-5
1.4.1 Remote control.....	1-5
1.4.2 Automatic acknowledge .....	1-5
1.4.3 Both remote control and automatic acknowledge ON .....	1-5
1.5 Interpreting Call Displays .....	1-6
1.5.1 Receive calls .....	1-6
1.5.2 Send calls.....	1-8
1.6 Remote Control of SSB Radiotelephone .....	1-9
<b>2. OPERATIONAL OVERVIEW</b> .....	<b>2-1</b>
2.1 Controls, LED Description.....	2-1
2.2 Turning the Power On/Off .....	2-3
2.3 DSC Standby Screen, Radiotelephone Setting Screen and Their Indications .....	2-3
2.3.1 DSC standby screen .....	2-3
2.3.2 Radiotelephone setting screen .....	2-3
2.4 Panel Backlighting, LCD Contrast and Brightness.....	2-4
2.5 Loudspeaker, Buzzer On/Off.....	2-5
2.6 Starting, Stopping Scanning DSC Routine Frequencies .....	2-6
2.7 Automatic Acknowledge On/Off .....	2-7
2.8 Intercom On/Off.....	2-8
2.9 Selection of On-screen Items.....	2-9
2.10 Manual Entry of Position and Time.....	2-10
2.11 Remote Control of FURUNO SSB Radiotelephone .....	2-12
<b>3. DISTRESS OPERATIONS</b> .....	<b>3-1</b>
3.1 Sending Distress Alert.....	3-1
3.1.1 Sending distress alert by DISTRESS button.....	3-1
3.1.2 Sending distress alert with nature of distress specified .....	3-3
3.2 Receiving a Distress Alert.....	3-7
3.2.1 Distress alert received on MF band .....	3-7
3.2.2 Distress alert received on HF band.....	3-13
3.3 Sending Distress Relay on Behalf of a Ship in Distress .....	3-15
3.3.1 Sending distress relay to coast station .....	3-15
3.3.2 Sending distress relay to all ships.....	3-18
3.4 Receiving Distress Relay All Ships from Ship.....	3-21
3.5 Receiving Distress Relay from Coast Station .....	3-21

4.	CALLING .....	4-1
4.1	All Ships Call .....	4-1
4.1.1	Sending all ships call .....	4-1
4.1.2	Receiving all ships call .....	4-3
4.2	Individual Call .....	4-4
4.2.1	Sending individual call .....	4-4
	How to set working frequency .....	4-6
	How to set DSC frequency .....	4-8
4.2.2	Receiving individual call .....	4-12
4.3	Group Call .....	4-17
4.3.1	Sending a group call .....	4-17
4.3.2	Receiving a group call .....	4-19
4.4	Geographical Area Call .....	4-20
4.4.1	Sending a geographical area call .....	4-20
4.4.2	Receiving a geographical area call .....	4-23
4.5	Neutral Craft Call .....	4-24
4.5.1	Sending a neutral craft call .....	4-24
4.5.2	Receiving a neutral craft call .....	4-25
4.6	Medical Transport Call .....	4-26
4.6.1	Sending a medical transport call .....	4-26
4.6.2	Receiving a medical transport call .....	4-27
4.7	Polling Call .....	4-28
4.7.1	Sending a polling call .....	4-28
4.7.2	Receiving a polling call .....	4-31
4.8	Position Call .....	4-33
4.8.1	Position call: requesting other ship's position .....	4-34
4.8.2	Position call: other ship requests your position .....	4-36
4.9	PSTN Call .....	4-39
4.9.1	Sending PSTN call, receiving acknowledge back (ACK BQ) .....	4-39
4.9.2	Sending PSTN call, receiving acknowledge back (QUEUE indication), ring back .....	4-43
4.9.3	Receiving PSTN call, sending acknowledge back (ACK BQ) .....	4-47
4.9.4	PSTN call disconnection, receiving charge information (ship disconnects line) .....	4-48
4.9.5	PSTN call disconnection, receiving charge information (coast station disconnects line) .....	4-50
5.	LOG FILE .....	5-1
5.1	Log File Description .....	5-1
5.2	Opening a Log File .....	5-1
5.2.1	Distress log .....	5-1
5.2.2	Ordinary log .....	5-3
5.2.3	Transmitted log .....	5-4
6.	PREPARING SEND MESSAGES .....	6-1
6.1	Preparing Individual Call Messages .....	6-1
6.2	Preparing Group Call Messages .....	6-4
6.3	Preparing Geographical Area Call Messages .....	6-5
6.4	Preparing PSTN Call Messages .....	6-7
6.5	Preparing Test Call Messages .....	6-8

6.6 Sending Prepared Messages.....	6-9
6.6 Printing List of Send Message Files.....	6-10
<b>7. SETUP MENU.....</b>	<b>7-1</b>
7.1 Setup Menu Overview.....	7-1
7.2 Alarm Menu.....	7-2
7.3 Auto Ack Menu.....	7-3
7.4 Erase File Menu.....	7-5
7.5 Message Menu.....	7-5
7.6 Position Menu.....	7-6
7.7 Print Out Menu.....	7-6
7.7.1 Sample printouts.....	7-7
7.8 Scan Freq Menu.....	7-8
7.8.1 Distress frequencies.....	7-8
7.8.2 Routine frequencies.....	7-9
7.9 User CH Menu.....	7-10
7.10 Volume Menu.....	7-12
7.11 Test Menu.....	7-13
7.12 System Menu.....	7-13
<b>8. CHECKING, MAINTENANCE.....</b>	<b>8-1</b>
8.1 Daily Test.....	8-1
8.2 Maintenance.....	8-2
8.2.1 Preventive maintenance.....	8-2
8.2.2 Cleaning.....	8-2
8.3 Simple Troubleshooting.....	8-3
8.4 Error Messages.....	8-3
8.5 Test Call.....	8-4
<b>APPENDIX.....</b>	<b>A-1</b>
Menu Tree.....	A-1
DSC Frequency Table.....	A-2

# FOREWORD

---

Thank you for purchasing this DSC/Watch Receiver. We are confident you will discover why FURUNO has become synonymous with quality and reliability.

Dedicated in the design and manufacture of marine electronics equipment for half a century, FURUNO Electric Company has gained an unrivaled reputation as a world leader in the industry. This is the result of our technical excellence as well as our worldwide distribution and service network.

Please carefully read and follow the safety information and operating and maintenance instructions set forth in this manual before attempting to operate the equipment and conduct any maintenance. Your DSC/Watch Receiver will perform to the utmost of its ability only if it is operated and maintained in accordance with the correct procedures.

## Features

Connected to an SSB radiotelephone, the DSC-60 generates and receives digital selective calls for quick and efficient establishment of distress, urgency, safety and routine communications with other ships and coast stations that install any MF/HF DSC facilities. Data is displayed on a large, easy-to-read backlit LCD. Operation is simplified by the use of few keys and easy-to-follow menus.

The main features are

- DSC Terminal, DSC Watch Receiver, DSC General Watch Receiver (option) and MF/HF Radiotelephone Remote Station all contained in a compact and light-weight cabinet.
- Fully meets GMDSS carriage requirements. Large LCD of 160-character indication.
- Conforms to the following standards and regulations:
  - IMO A. 694(17)
  - IMO A. 806(19)
  - IMO A. 813(19)
  - IMO MSC 68(68)
  - IEC-61097-3/8/9
  - IEC-60945 (3<sup>rd</sup> edition)
  - IEC-61162-1
  - ETS-300/338
  - ITU-R M.493-9, M.541-8, M.1082-1
- Scan watch feature scans operator-programmed DSC frequencies.
- Remote operation optionally available.
- Automatic position and time input and update with connection of EPFS (Electronic Position-Fixing Equipment).
- Optional printer can automatically print out received messages and test results.
- Log stores 50 each of latest ordinary, distress and transmitted messages, in separate memory blocks.

- Built-in intercom function provides voice communications between the DSC-60 and SSB radiotelephone.
- Optional built-in receiver board for DSC ship's business/routine frequencies.
- One-touch testing facility.

## Program number

MAIN CPU 0550201002

MODEM 0550202001

# 1. DSC SYSTEM OVERVIEW

## 1.1 What is DSC?

DSC is an acronym meaning Digital Selective Calling. It is a digital distress and general calling system in the MF, HF and VHF bands used by ships for transmitting distress alerts and general calls and by coast stations for transmitting the associated acknowledgements.

For DSC distress and safety calling in the MF and HF bands the frequencies are (kHz) 2187.5, 4207.5, 6312.0, 8414.5, 12577.0, and 16804.5.

The DSC-60 is a combination MF/HF DSC Terminal and Watch Receiver. Connected to an SSB radiotelephone, the DSC-60 sends and receives calls via the SSB radiotelephone. The built-in remote control permits control of a FURUNO radiotelephone from the DSC-60.

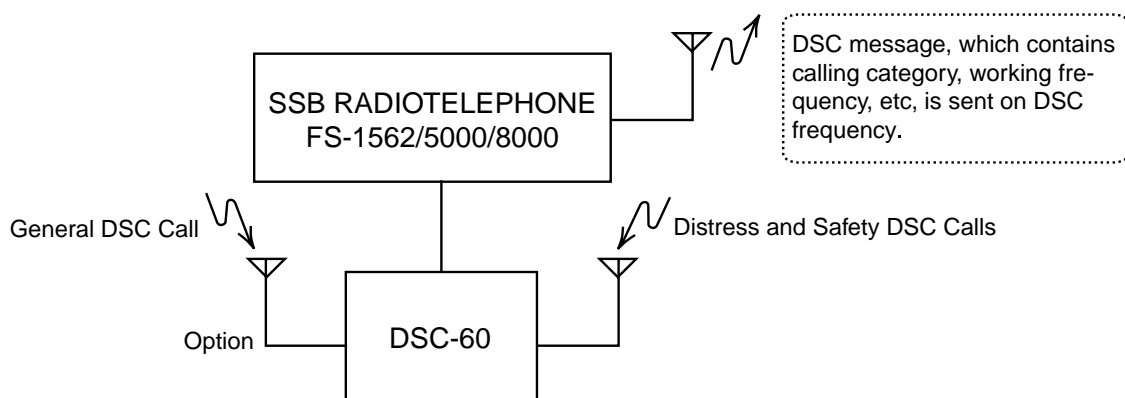

## 1.2 DSC Call

DSC calls are roughly divided in two categories: distress and safety calls, and routine calls. Below are the types of DSC calls and the pages on which their descriptions and procedures appear.

- All Ships (page 4-1)
- Distress (your ship is in distress) (page 3-1)
- Distress relay all (all ships) (page 3-18)
- Distress relay sel (coast station) (page 3-15)
- Geographical Area (page 4-20)
- Group (page 4-17)
- Individual (page 4-4)
- Medical Transport (page 4-26)
- Neutral Craft (4-24)
- Polling (page 4-28)
- Position (page 4-33)
- PSTN (page 4-39)
- Test (page 8-4)

## Contents of a DSC call

### Calling category

Call category	Call
Individual	Individual, PSTN, Test, Position, Polling, Relay Sel (specific coast station)
All Ships	All Ships, Neutral, Medical, Relay All
Group	Group
Geographical Area	Area

### Station ID

Own ship ID and sending station ID. Coast station ID begins with 00; Group ID begins with 0.

### Priority

**Distress:** Grave and imminent danger and request immediate assistance.

**Safety:** A station is about to transmit a message containing an important navigational or meteorological warning.

**Urgency:** A calling station has a very urgent message to transmit concerning safety of ship, aircraft or other vehicle or safety of person.

**Business:** Communication related to the navigation, movements and needs of ships and aircraft.

**Routine:** General calling

### Communication type

Telephone: telephone (J3E) by SSB

NBDP-ARQ: Telex (J2B) mode ARQ via NBDP Terminal

NBDP-FEC: Telex (J2B) mode FEC via NBDP Terminal

### Communication frequency

Working frequency used to call by telephone or NBDP. The sending station may have the receiving station (ship or coast station) assign the frequency to use.

### Position

Position can be automatically or manually input.

### DSC frequency

DSC frequency to use. If the order of communications priority is SAFETY, URGENCY and DISTRESS, select a DSC distress frequency.

### End code

The end of a DSC message is denoted by ACK RQ (Acknowledge Request), ACK BQ (Acknowledge Back) or EOS (End of Sequence).



## 1.2.1 Distress alert call and reply

This type of call is sent by own ship in the event of distress, by pressing the [DISTRESS] button more than three seconds as follows:

1. The LED in the button initially flashes, and lights when the button is pressed more than three seconds. (If the button is pressed less than three seconds the distress alert is not sent. Once the alert is sent it cannot be cancelled.)

**⚠ WARNING**

**IN CASE OF ACCIDENTAL TRANSMISSION OF THE DISTRESS ALERT**

If the distress is accidentally transmitted, contact the nearest coast station and inform them of the accidental transmission as follows:

- a) Ship's name
- b) Ship's call sign and DSC number
- c) Position at time of transmission
- d) Time of transmission

2. The DSC-60 sets the DSC distress frequency on the SSB radiotelephone and it transmits the distress alert.
3. After the distress alert is transmitted (about 40 seconds) the DSC-60 waits for the DIST ACK call from a coast station. This usually takes less than 3 minutes and is accompanied with an audio alarm. (If it is not received within 4.5 minutes the distress alert is re-transmitted.)
4. The SSB sets the DSC distress frequency to use to communicate with the coast station. With the optional handset you can communicate through the DSC-60.

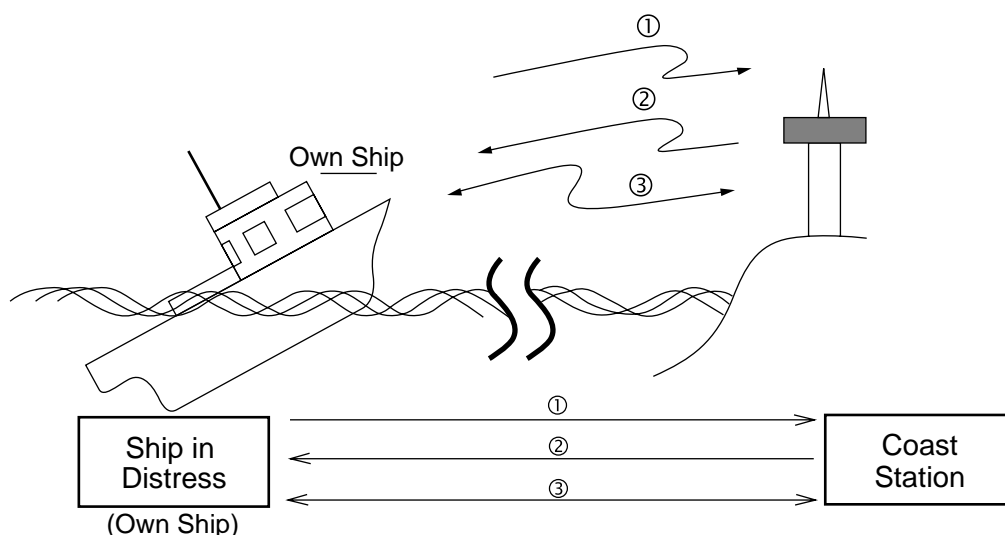

- ① Ship in distress sends Distress Alert.
- ② Coast station sends distress acknowledgement (DIST ACK).
- ③ Voice or telex communications between ship in distress and coast station

## 1.2.2 Individual call

The individual call is for sending a call to a specific station.

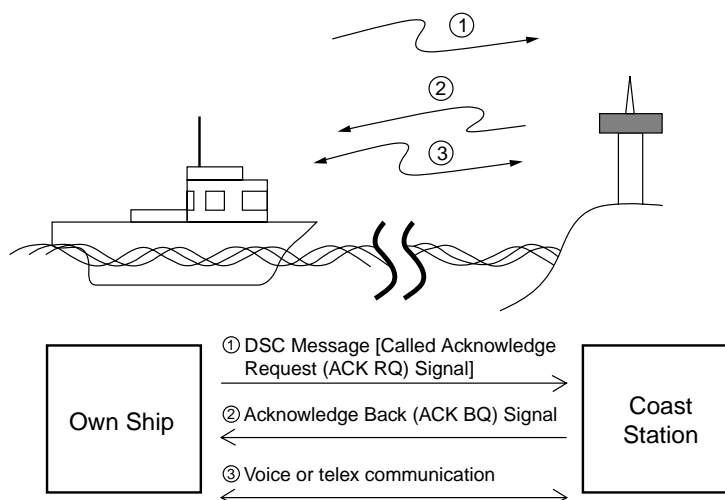

### Basic procedure

1. Prepare message and transmit it by pressing the [CALL] key. The DSC-60 then awaits acknowledgement of the call.
2. Receive acknowledge back (ACK BQ) signal from receiving station (coast station or ship station) within about five minutes. The audio alarm sounds at this time; press the [CANCEL] key to silence it.
3. After receiving ACK BQ signal, communicate with coast station; the FURUNO SSB radiotelephone sets the working frequency and class of emission specified by your ship.

## 1.3 Audio Alarms

When you receive a distress alert or routine call addressed to your ship the audio and visual alarms are released. For the distress or urgent call, the audio alarm sounds until the [CANCEL] key is pressed. For other calls, the audio alarm sounds for one second and then automatically goes off.

The tone of the alarm depends on the call received. By becoming accustomed to the tone you can know which type of call you have received.

Alarm	Frequency (interval)
Safety message received	1300 Hz and 0 Hz (250 ms)
Routine, Ship's Business message received	880 Hz and 440 Hz (500 ms)
While DISTRESS button is pressed for three seconds	2200 Hz and 0 Hz (125 ms)
Distress alert is being sent	2200 Hz, continuous
Own ship position not updated	2200 Hz (50 ms), three beeps every two seconds

## 1.4 Remote Control and Automatic Acknowledge

### 1.4.1 Remote control

The DSC-60 and a FURUNO SSB radiotelephone communicate with each other by means of the MIF (FURUNO Radio Interface) protocol, a unique handshaking type signal exchange system developed by FURUNO. The DSC-60 can also communicate with other makes of radiotelephones which incorporate data format IEC-61162-1. The remote control feature allows the DSC-60 to automatically set the DSC and working frequencies and class of emission on a FURUNO SSB radiotelephone.

### 1.4.2 Automatic acknowledge

The automatic acknowledge feature, when turned on, automatically transmits the acknowledge back signal to the sender when an individual, position or polling call is received. With the automatic acknowledge feature turned on the remote control is also turned on.

Automatic acknowledge is alternately enabled or disabled with the [5/ACK] key.

### 1.4.3 Both remote control and automatic acknowledge ON

The illustration and table below outline the sequence of events in an individual call when both remote control and automatic acknowledge are turned on.

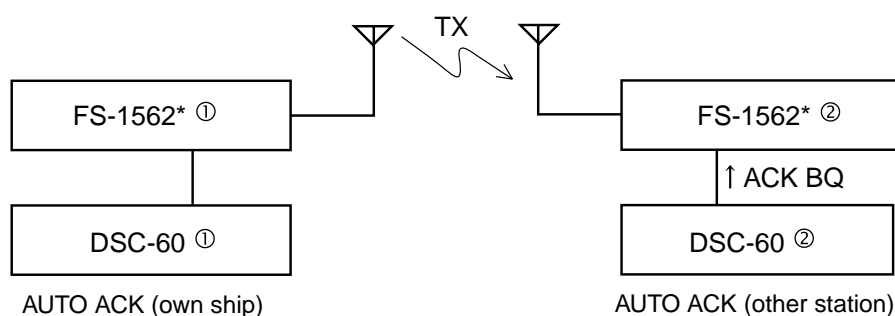

\* FURUNO SSB radiotelephone

DSC operation	Radiotelephone frequency ①	Radiotelephone frequency ②
1. DSC-60① [CALL] key pressed.	DSC frequency changed; call sent.	Scans DSC frequencies.
2. DSC-60② receives via radiotelephone.		Sets DSC frequency received.
3. DSC-60② automatically sends acknowledge back (ACK BQ) signal.		DSC frequency set; ACK BQ sent. Then, working frequency and class of emission specified at DSC-60① are set.
4. DSC-60① receives acknowledge back signal via radiotelephone.	Working frequency and class of emission specified at DSC-60① are set.	
Both communication frequency and class of emission are already set on the FS-1562 ① and FS-1562②, so you may begin communications.		

# 1.5 Interpreting Call Displays

This paragraph provides the information necessary for interpreting receive and send calls.

## 1.5.1 Receive calls

Below are sample distress and individual receive calls. Content of other receive calls is similar to that of the individual call.

### Distress call

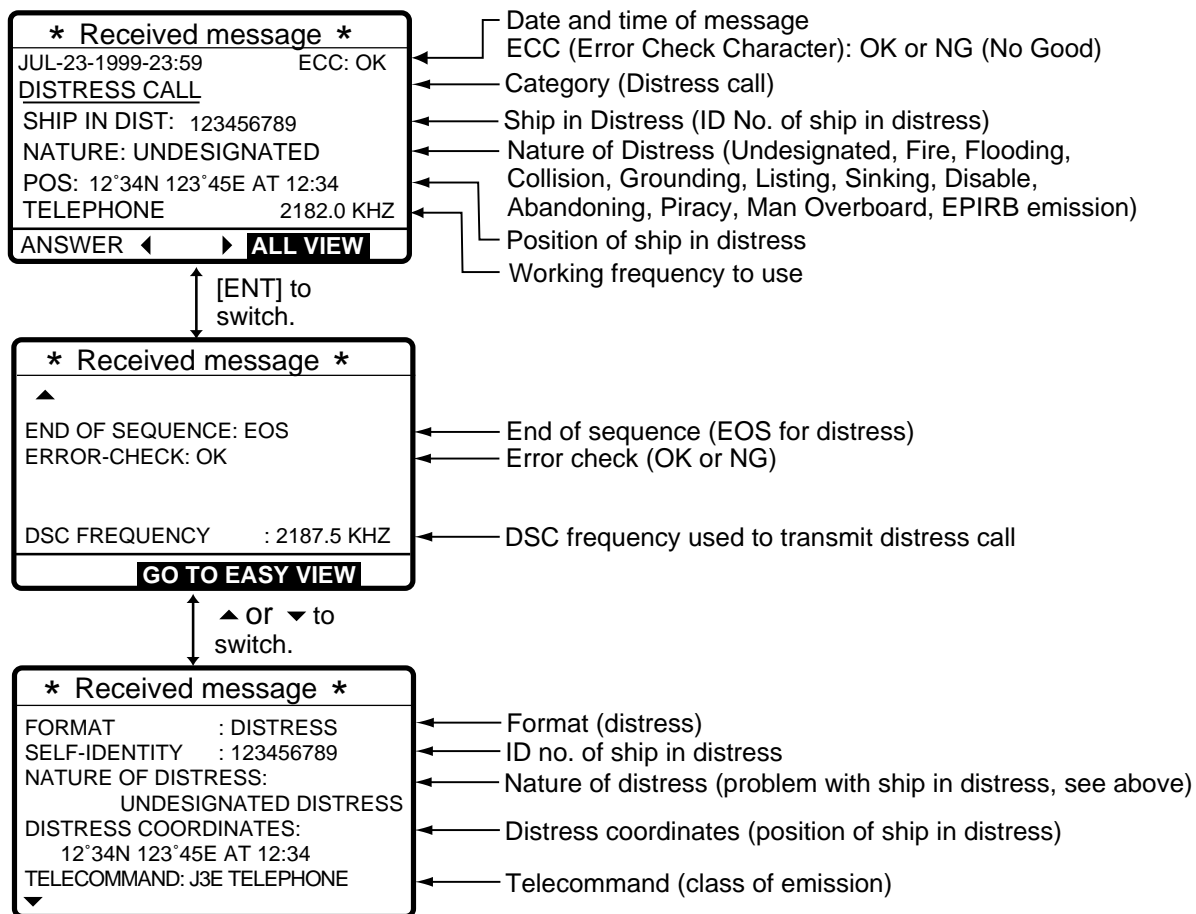

## Individual call

```

* Received message *
JUL-23-1999-23:59      ECC: OK
INDIVIDUAL REQUEST
FROM SHIP:      123456789
ROUTINE
TELEPHONE      2182.0 KHZ
ANSWER ◀      ▶ ALL VIEW
  
```

- ← Date and time of message
- ← ECC (Error Check Character): OK or NG (No Good)
- ← Able to acknowledge ("Unable to acknowledge" and reason if unable)
- ← ID No. of sending station
- ← Category (Routine, Business, Safety, Urgency)
- ← Working frequency to use

**Note:** ANSWER is for replying to message.

↑ [ENT]  
to switch.

```

* Received message *
▲
WORKING FREQUENCY : 2182 KHZ
END OF SEQUENCE: ACK. RQ
ERROR-CHECK: OK
DSC FREQUENCY TX: 2189.5 KHZ
                  RX: 2177.0 KHZ
GO TO EASY VIEW
  
```

- ← Working frequency to use
- ← End of sequence (ACK. BQ or ACK. RQ)
- ← Error check (OK or NG)
- ← DSC frequency used

↑ ▼ or ▲  
to switch.

```

* Received message *
FORMAT      : INDIVIDUAL
ADDRESS     : 987654321
CATEGORY    : ROUTINE
SELF-IDENTITY : 123456789
1ST TELECOMMAND: J3E TELEPHONE
2ND TELECOMMAND: NO INFORMATION
▼
  
```

- ← Format (individual)
- ← ID of your station
- ← Category (Routine, Business, Safety, Urgency)
- ← ID of sending station
- ← 1st Telecommand (class of emission)
- ← 2nd Telecommand (class of emission)

## 1.5.2 Send calls

Below are sample distress and individual send calls. Content of other send calls is similar to that of the individual call.

### Distress call

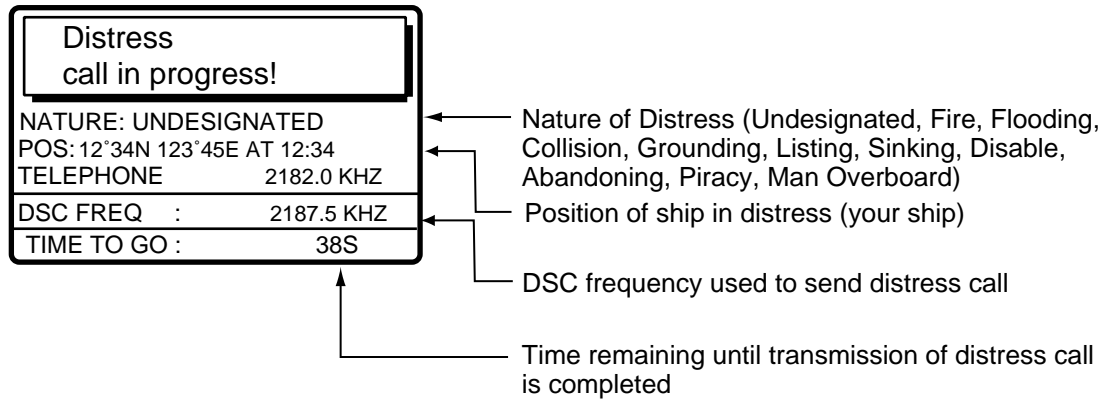

### Individual call

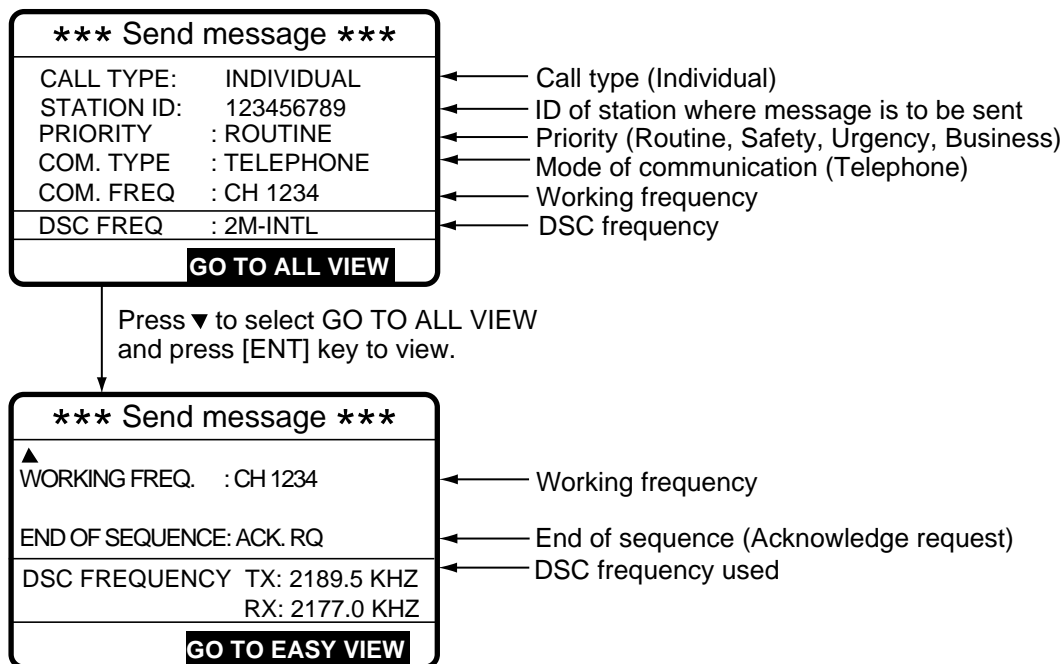

## 1.6 Remote Control of SSB Radiotelephone

### SSB output power at transmission of distress alert

When the [DISTRESS] button is pressed, the output power of the FURUNO SSB radiotelephone is automatically set to maximum, even if it is set for minimum.

### Keyboard lock at the SSB radiotelephone

The keyboard of the FURUNO SSB radiotelephone is automatically locked while a DSC message is being transmitted.

- Distress alert or distress relay transmitted (transmission time about 40 seconds)  
The keyboard is locked until the transmission of the distress alert or distress relay is completed.
- Call other than distress is transmitted (transmission time about 8 seconds)  
Press the [CANCEL] key to unlock the keyboard.

This page is intentionally left blank.



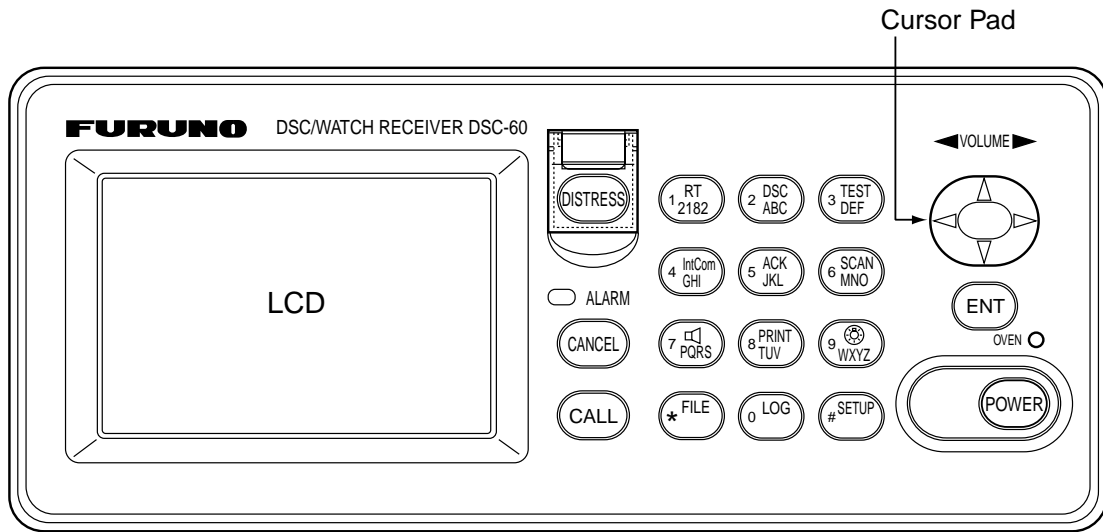

# 2. OPERATIONAL OVERVIEW

## 2.1 Controls, LED Description



Control, LED description

Control	Function
POWER switch	Turns the power on/off.
DISTRESS button	Press and hold down the button more than three seconds to transmit the distress alert. When pressed it initially flashes, and lights up if the button is pressed more than three seconds. It stays lit until your ship receives the distress acknowledge message. The distress alert will not be transmitted if the button is pressed less than three seconds.
CALL key	Transmits calls other than distress.
Cursor Pad	Selects items on menus; adjusts loudspeaker volume (64 levels) on the DSC standby screen. (The distress and urgency alarms are received at maximum volume regardless of current loudspeaker volume setting.)
ENT key	Registers key input.
CANCEL key	<ul style="list-style-type: none"> <li>• Cancels wrong data.</li> <li>• Restores previous menu.</li> <li>• Returns to DSC standby screen from other screen.</li> <li>• Silences audio alarm (distress or routine).</li> <li>• Cancels transmission, printing.</li> <li>• Erases error message.</li> </ul>
1/ RT/2182 key	<ul style="list-style-type: none"> <li>• Switches from the DSC standby screen to the radiotelephone setting screen.</li> <li>• Switches to 2182.0 kHz/J3E on radiotelephone setting screen by pressing more than two seconds.</li> </ul>
2/DSC key	Switches from the radiotelephone setting screen to the DSC standby screen.
3/TEST key	Executes daily test.
4/IntCom key	Turns intercom with radiotelephone on/off, from the radiotelephone setting screen.
5/ACK key	Switches automatic and manual acknowledge alternately at the DSC standby screen.
6/SCAN key	Starts/stops scanning of DSC routine frequencies at the DSC standby screen.
7/  key	<ul style="list-style-type: none"> <li>• Turns loudspeaker on/off.</li> <li>• Silences buzzer.</li> </ul> <p>Note that this key does not silence the distress or urgency alarm.</p>
8/PRINT key	Prints communications log files, current screen (except DSC standby screen and radiotelephone setting screen) and test results.
9/  key	Adjusts keyboard/LCD backlighting and LCD contrast.
*/FILE key	<ul style="list-style-type: none"> <li>• Opens the send message file from the DSC standby screen, to send stored message.</li> <li>• Selects station or coast ID when preparing an individual message.</li> </ul>
0/LOG key	Opens the Tx/Rx log file from the DSC standby screen.
#/SETUP key	Opens the Setup menu from the DSC standby screen.
ALARM lamp	<ul style="list-style-type: none"> <li>• Flashes in red for distress or urgency call.</li> <li>• Flashes in green (more rapidly) for safety or routine call.</li> </ul>
OVEN lamp	Lights (in green) when oven power is on.

## 2.2 Turning the Power On/Off

Press the [POWER] switch at the right-hand side of the equipment to turn the power on or off. Whenever the power is applied the DSC standby screen appears.

## 2.3 DSC Standby Screen, Radiotelephone Setting Screen and Their Indications

### 2.3.1 DSC standby screen

The DSC standby screen appears by pressing the [2/DSC] key. This is where you begin all calling operations.

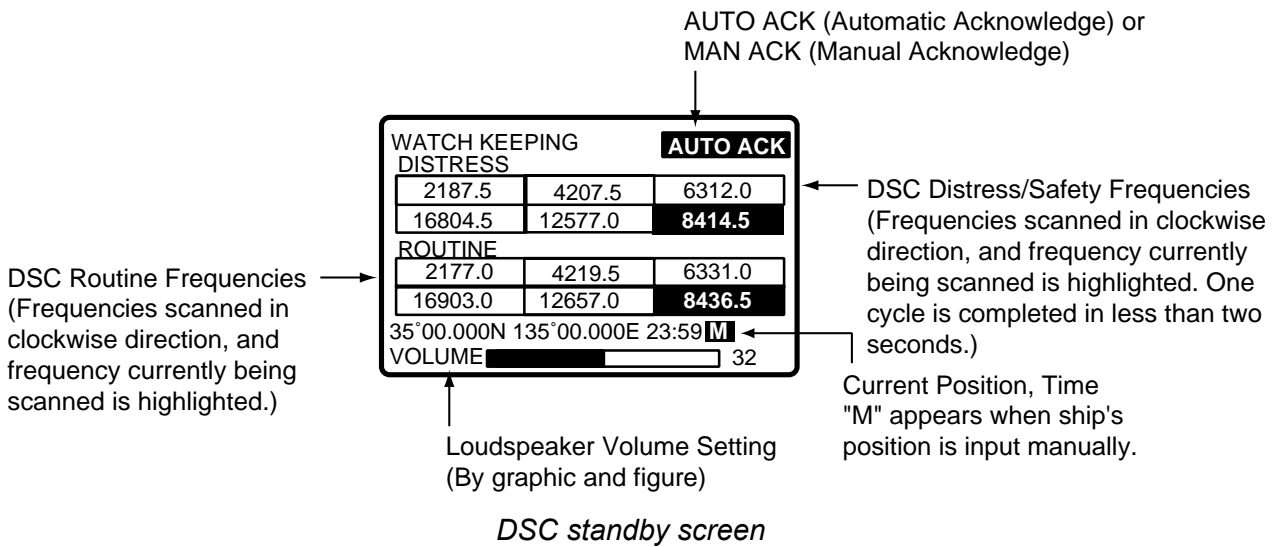

### 2.3.2 Radiotelephone setting screen

The radiotelephone setting screen appears by pressing the [1/ RT/2182] key. This is where you set up the radiotelephone.

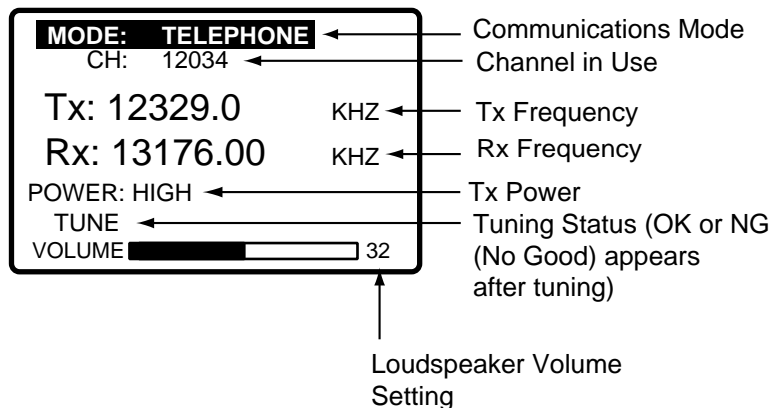

**Note:** "Tx" pops out when the radiotelephone is transmitting.

## 2.4 Panel Backlighting, LCD Contrast and Brightness

1. At the DSC standby screen or radiotelephone setting screen, press the [9/⊗] key. The following display appears.

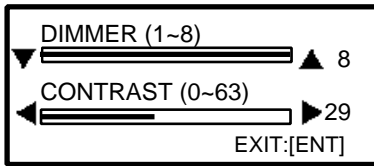

2. Use ▲ to increase the panel backlighting, LCD brightness; ▼ to lower it. Current backlighting setting is shown in both digital and analog indications below DIMMER.
3. Use ◀ to lower the LCD contrast; ▶ to raise it. Current contrast setting is shown in both digital and analog indications below CONTRAST.
4. Press the [ENT] key to finish and return to the screen previously in use.

## 2.5 Loudspeaker, Buzzer On/Off

1. Display the DSC standby screen or radiotelephone setting screen.
2. Press the [7/🔊] key to turn the loudspeaker and the alarm generated for ordinary messages (others than distress and urgency) on/off. The message SOUND: ON or SOUND: OFF appears with each pressing of the key. The indication OFF appears at the lower-right side of the DSC standby and radiotelephone setting screens when the loudspeaker is turned off.

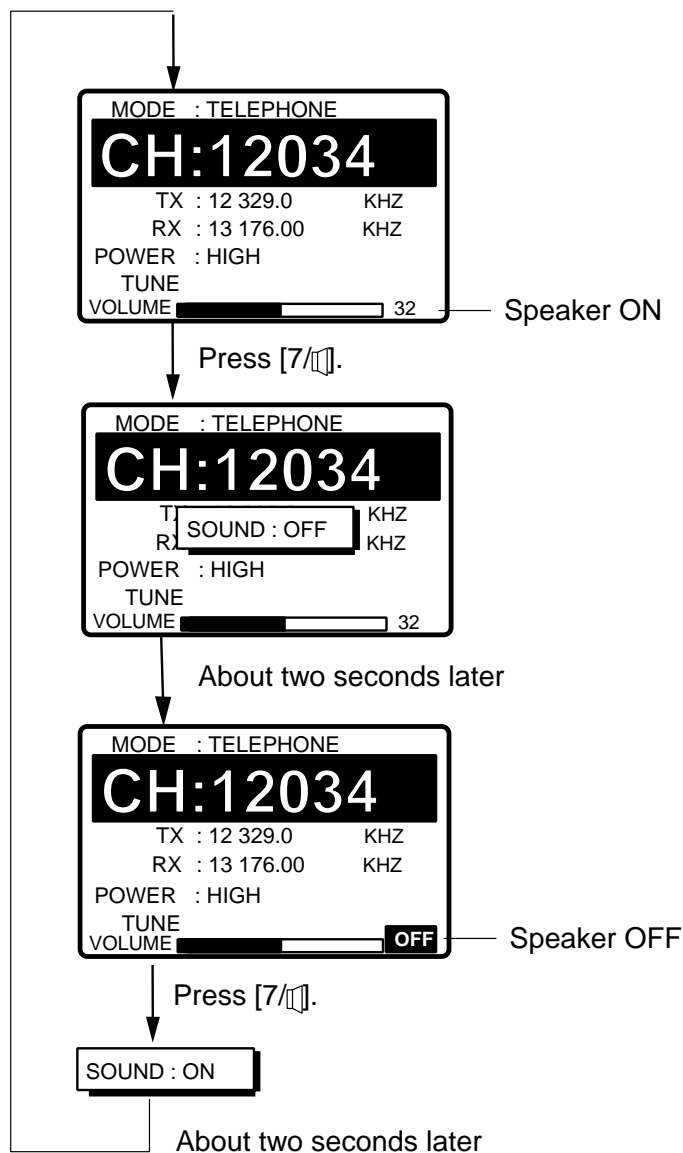

3. When the loudspeaker is on, press ◀ to lower the volume; ▶ to raise it. The setting range is 0 to 63. Current volume setting is shown by both bar graph and numeric at the bottom of the display.

**Note:** The volume setting is set to 5 and the loudspeaker is ON whenever the unit is powered on.

## 2.6 Starting, Stopping Scanning DSC Routine Frequencies

Press the [6/SCAN] key at the DSC standby screen to start or stop scanning DSC routine frequencies. The DSC routine frequencies to scan can be selected through the menu. Note that scanning of DSC distress frequencies cannot be stopped.

The screenshot shows a menu with the following content:

WATCH KEEPING		<b>AUTO ACK</b>
DISTRESS		
2187.5	4207.5	6312.0
<b>6804.5</b>	12577.0	8414.5
ROUTINE		
2177.0	4219.5	6331.0
<b>16903.0</b>	12657.0	8436.5

35°00.000N 135°00.000E 23:59  
VOLUME

Annotations:

- An arrow points from the text "DSC routine frequency currently being scanned is highlighted." to the highlighted value 16903.0 in the ROUTINE section.
- An arrow points from the text "DSC distress frequency currently being scanned is highlighted." to the highlighted value 6804.5 in the DISTRESS section.

**Note:** DSC routine frequencies may not be received when optional receiver board (for receiving DSC routine frequencies) is installed and you receive a distress signal when you are close to the sender of the frequency.

## 2.7 Automatic Acknowledge On/Off

The automatic acknowledge feature, when turned on, automatically transmits the acknowledge back (ACK BQ) signal to the sender when an individual, position, or polling call is received. (For position and polling calls, respective item on the AUTO ACK menu must be turned on to enable automatic acknowledge.) It can be turned on or off at the DSC standby screen by pressing the [5/ACK] key. The message AUTO ACK or MANUAL ACK appears at the top-right corner of the DSC standby screen with each press of the key.

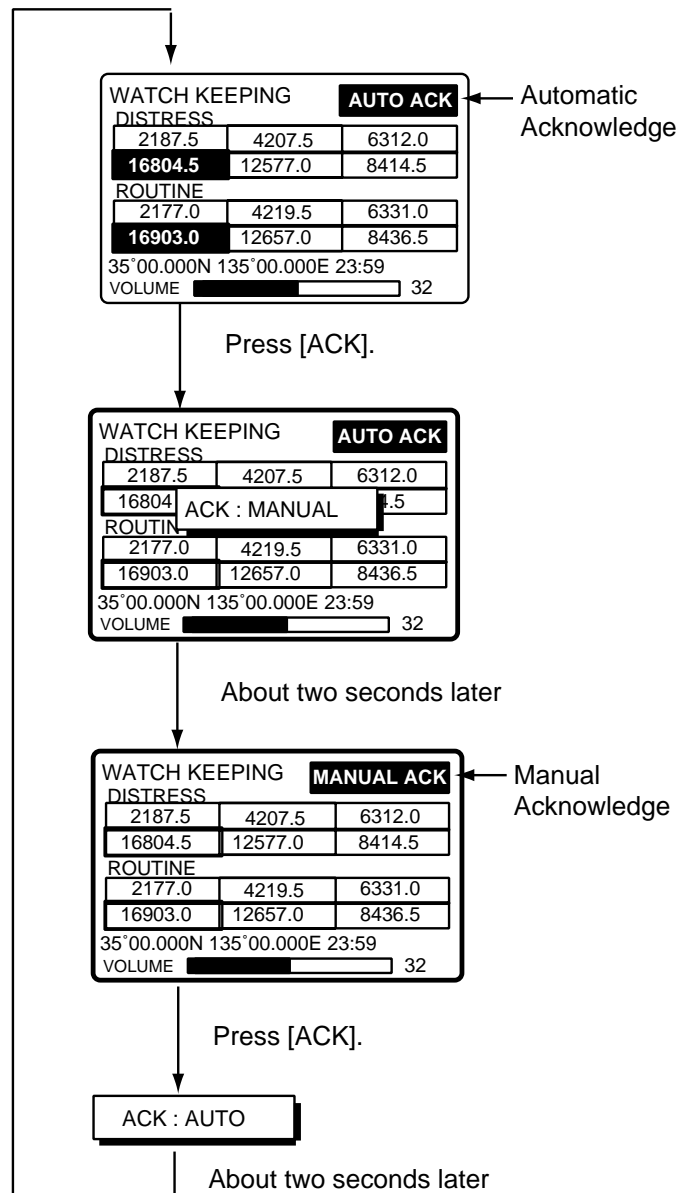

**Note:** To give communications priority to own ship's communications while own ship is communicating, select MANUAL ACK.

## 2.8 Intercom On/Off

The built-in intercom permits voice communications between the DSC-60 and the SSB radiotelephone to which it is connected.

1. Display the radiotelephone setting screen.
2. Off hook the handset.
3. Press the [4/IntCom] key. You can begin communications with the SSB radiotelephone.

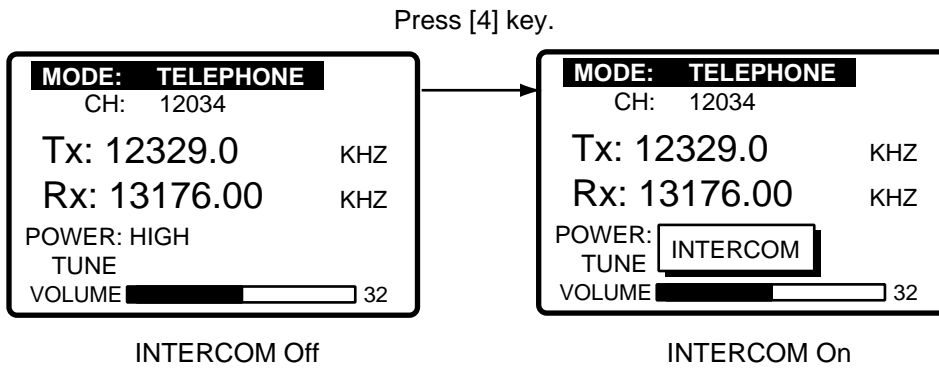

4. Hang up the handset when finished with communications to turn the intercom off. The indication INTERCOM disappears from the radiotelephone setting screen when the intercom is turned off.

**Note:** If you are called from other onboard SSB radiotelephone, a beep sounds. Off hook the handset and begin communications.



## 2.9 Selection of On-screen Items

Menu and calling operations are executed by selecting on-screen items. The example below shows how to select items and options from the Alarm menu.

1. Press the [#/SETUP] key to display the Setup menu.

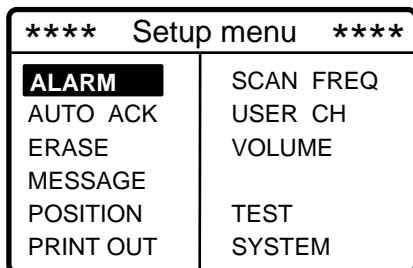

2. Use the Cursor Pad to select a menu and then press the [ENT] key. For example, select the ALARM menu.

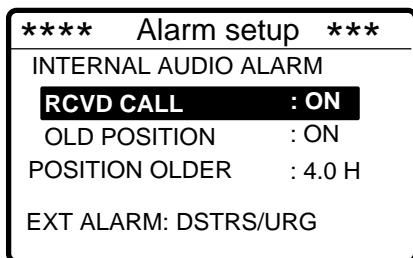

3. Use ▲ or ▼ to select menu item desired and press the [ENT] key. For example, select RCVD CALL. The following window appears, superimposed on the main window.

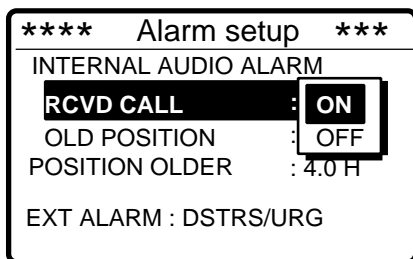

4. Use ▲ or ▼ to select option.
5. Press the [ENT] key to register your selection and the [CANCEL] key twice to return to the DSC standby screen.

## 2.10 Manual Entry of Position and Time

If there is no EPFS (Electronic Position-Fixing System) connected to the DSC-60 or the EPFS connected is inoperative, manually enter position and time as follows:

1. At the DSC standby screen, press the [# / SETUP] key to display the Setup menu.

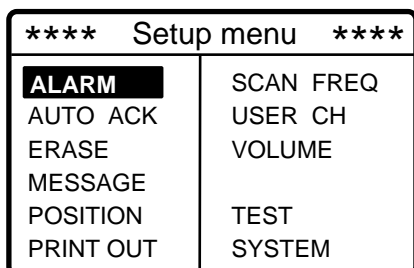

2. Select POSITION and press the [ENT] key to display the Position menu.

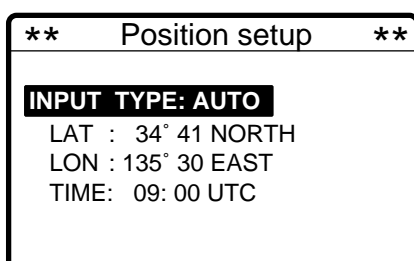

3. Press the [ENT] key to open the INPUT TYPE menu.

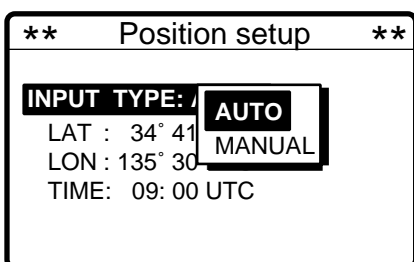

**Note 1:** If, when AUTO is selected, input from the navigator is interrupted the message “EPFS error!” appears. If this occurs check the navigator.

**Note 2:** If, when MANUAL is selected, the message “Warning: Update position” appears at set intervals to ask you to update position. For further details see page 7-2.

4. Press ▼ to select MANUAL and press the [ENT] key.
5. Press the [ENT] key to open the latitude entry window.

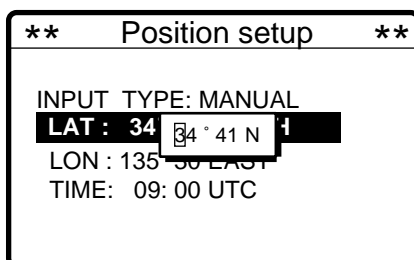

**Note:** Use ▼ to switch from North to South and vice versa.

6. Enter latitude in four digits and press the [ENT] key.
7. Press the [ENT] key to open the longitude entry window.

```
** Position setup **
INPUT TYPE: MANUAL
LAT : 34° 41 NORTH
LON : 135 135°00 E
TIME: 09:00 UTC
```

**Note:** Use  $\blacktriangledown$  to switch from East to West and vice versa.

8. Enter longitude in five digits and press the [ENT] key.
9. Press the [ENT] key to open the time entry window.

```
** Position setup **
INPUT TYPE: MANUAL
LAT : 34° 41 NORTH
LON : 135° 30 EAST
TIME: 09:12:34
```

10. Enter UTC time and press the [ENT] key. The Setup menu appears.

## 2.11 Remote Control of FURUNO SSB Radiotelephone

A FURUNO SSB radiotelephone can be controlled from the radiotelephone setting screen, which may be displayed by pressing the [1/ RT/2182] key. You can enter desired frequency by designating channel as below or entering Tx and Rx frequencies as on the next page. The handset must be off hook to set the radiotelephone.

**Note:** To set the SSB radiotelephone to 2182 kHz/J3E, press the [1/ RT/2182] key more than 2 sec.

### Mode selection

1. Press the [1/ RT/2182] key to display the radiotelephone setting screen.
2. Select the MODE field with the Cursor Pad and press the [ENT] key.
3. Select mode desired and press the [ENT] key.

TELEPHONE: Telephone

NBDP/DSC: NBDP Terminal, DSC Terminal

FAX: Facsimile

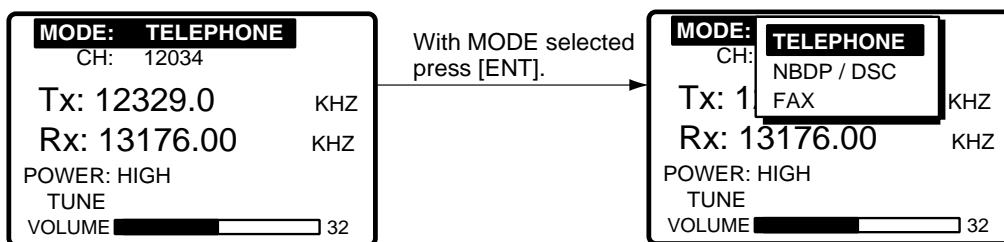

### Channel selection

Channel cannot be selected when the MODE is FAX.

1. Select the CH field and press the [ENT] key.

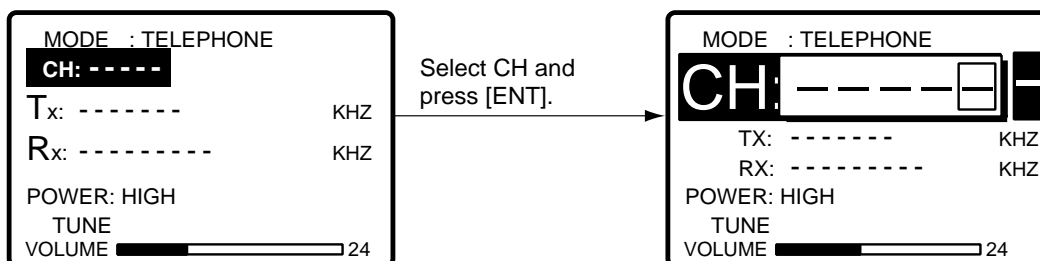

2. Channel can be entered directly with the numeric keys, or with the cursor pad.

#### By numeric keys

Use the numeric keys to enter band and channel and then press the [ENT] key.

### By Cursor Pad

- Press ◀ to shift the cursor to the band entry location.
- Use ▲ or ▼ to set band. Band is displayed in the following sequence.

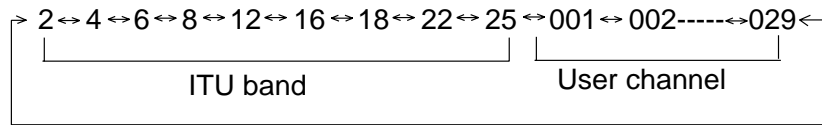

- Press ▶.
- Use ▲ or ▼ to set channel.
- Press the [ENT] key. The Tx and Rx frequencies of the channel entered appear.

### Setting Range

ITU Band:	2/4/6/8/12/16/18/24/25
User Band:	01-029
ITU Channel:	XX001 - XX193
User Channel:	XXX01 - XXX99

### Tx/Rx frequency selection

Select the Tx or Rx field and press the [ENT] key. Enter desired frequency with the numeric keys. Press the [ENT] key to finish.

**Note:** If you enter the Tx frequency, the same frequency is entered to the Rx frequency.

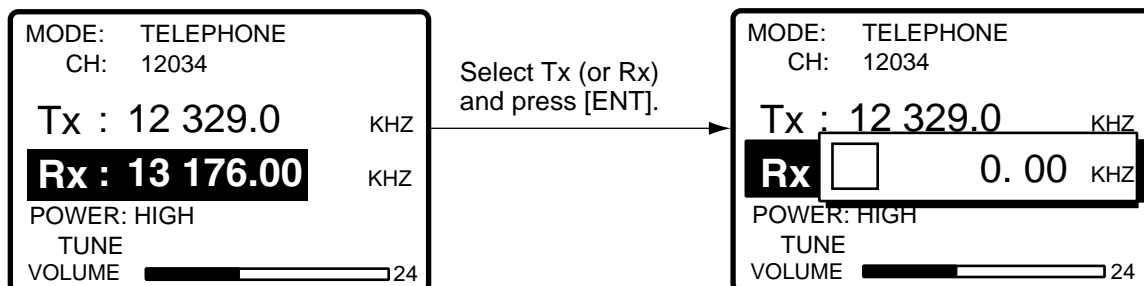

### Power selection

Select the POWER field with the Cursor Pad and press the [ENT] key. Select power desired among HIGH, MID and LOW with the Cursor Pad and press the [ENT] key.

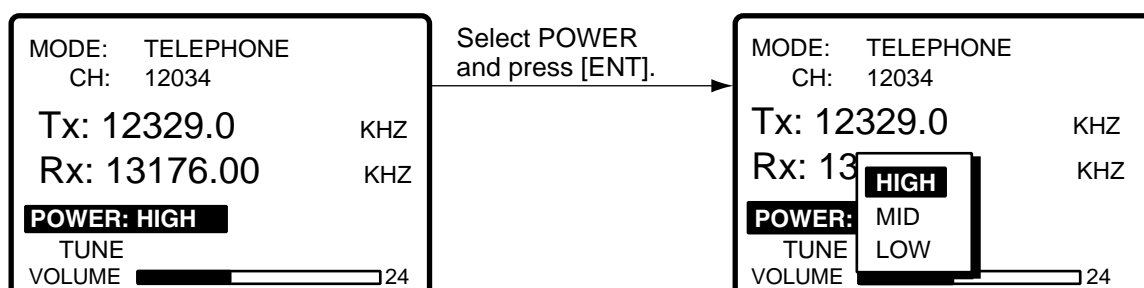

**Note:** Some FURUNO SSB radiotelephones do not provide the power selection HIGH, MID or LOW.

## Tuning

Select the TUNE field with the Cursor Pad and press the [ENT] key. Tuning is automatically executed, showing TUNING while tuning. The results are shown as TUNE: OK or TUNE: NG (No Good).

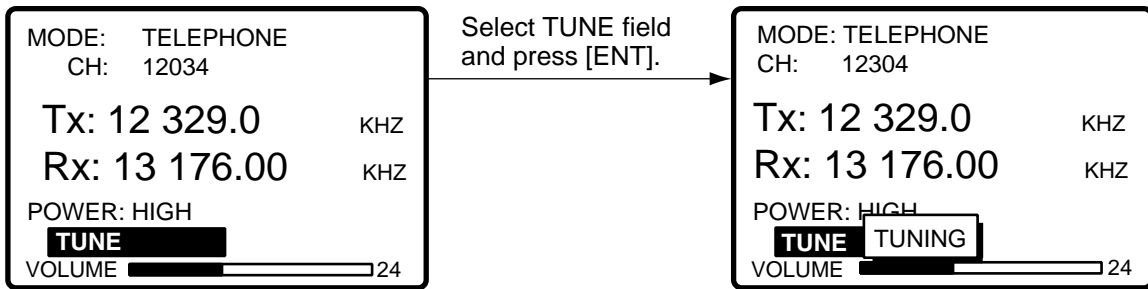

# 3. DISTRESS OPERATIONS

## 3.1 Sending Distress Alert

### 3.1.1 Sending distress alert by DISTRESS button

GMDSS ships carry a DSC terminal with which to transmit the distress alert in the event of a life endangering situation onboard ship. A coast station receives the distress alert and sends the distress alert acknowledge message to the ship in distress. Then, voice or telex communications between the ship in distress and coast station begins, via the radiotelephone.

Transmission of the distress alert and receiving of distress alert acknowledgement are completely automatic - simply press the [DISTRESS] button to initiate the sequence.

1. Open the DISTRESS button cover and press and hold down the [DISTRESS] button more than three seconds. The button flashes in red and the buzzer sounds rapidly. The display shows the contents of the distress alert call: your ship's nature of distress and position, time, and DSC frequency used to transmit the alert.

The number of seconds to continue pressing the [DISTRESS] button appear at the bottom of the display. The buzzer sounds continuously and the lamp in the button lights when the button has been pressed three seconds. You can release the button at that time.

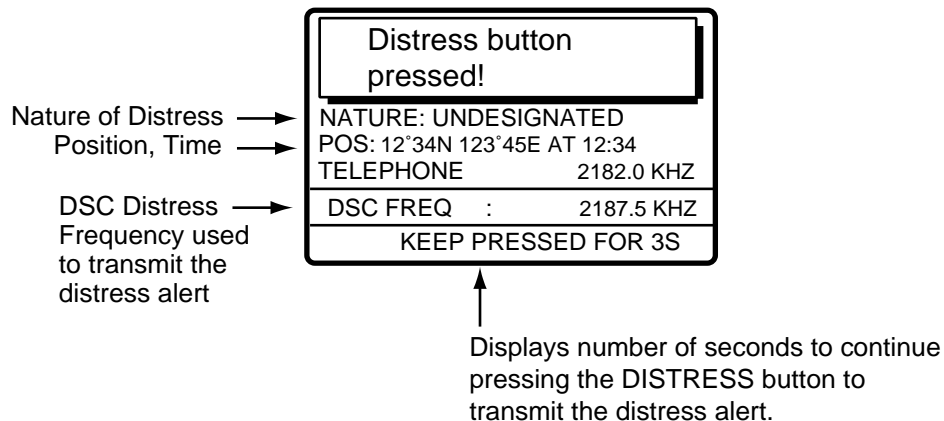

- The display changes as below. It takes about 40 seconds to complete transmission of the distress alert, and the number of seconds until transmission is completed is shown at the bottom of the display.

At this time the output power of the radiotelephone is automatically set to maximum.

Distress call in progress!	
NATURE: UNDESIGNATED	
POS: 12°34N 123°45E AT 12:34	
TELEPHONE	2182.0 KHZ
DSC FREQ :	2187.5 KHZ
TIME TO GO :	38S



Time to go until distress alert transmission is completed.

- After the distress alert has been sent the display changes as below. This is where the equipment waits to receive the distress acknowledge message from a coast station, which usually takes about one minute to three minutes. (The [DISTRESS] button remains lit until the DSC-60 receives the distress acknowledge message from a coast station.) The timer counts down the number of minutes to wait, from 3.5 to 4.5 minutes, randomly set.

At this time the DSC-60 cannot receive any messages except the distress alert acknowledge message. Distress message is recorded in the Tx log.

Wait for distress acknowledgement.	
NATURE: UNDESIGNATED	
POS: 12°34N 123°45E AT 12:34	
TELEPHONE	2182.0 KHZ
DSC FREQ :	2187.5 KHZ
TIME TO GO:	3M10S

- When the distress acknowledge call is received the audio alarm sounds and the display changes as below.

Distress acknowledge call received.	
FROM COAST: 001234567	
SHIP IN DIST: 123456789	
NATURE: UNDESIGNATED	
POS: 12°34N 123°45E AT 12:34	
TELEPHONE	2182.0 KHZ
<b>STOP ALARM</b>	

**Note:** If you do not receive the distress alert acknowledge call, the DSC-60 re-transmits the distress alert and then awaits the distress alert acknowledge call. This is repeated until the distress alert is acknowledged.



- Silence the alarm with the [CANCEL] or [ENT] key. The receive message appears as in the figure below.

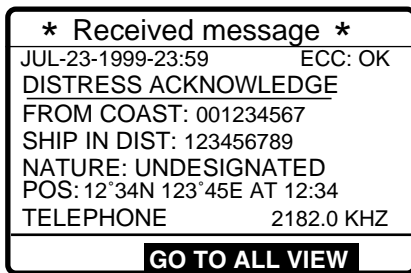

- Communicate with the coast station via radiotelephone, which is automatically set to working frequency and class of emission (telephone) specified in the distress acknowledge message.
  - Say MAYDAY three times.
  - Say “This is ... “ name of your vessel and call sign three times.
  - Give nature of distress and assistance needed.
  - Give description of your vessel (type, color, number of persons onboard, etc.).

### 3.1.2 Sending distress alert with nature of distress specified

If you have the time to designate the nature of distress, send the distress alert as follows:

- Open the DISTRESS button cover and press the [DISTRESS] button with a touch-and-release action. The following display appears.

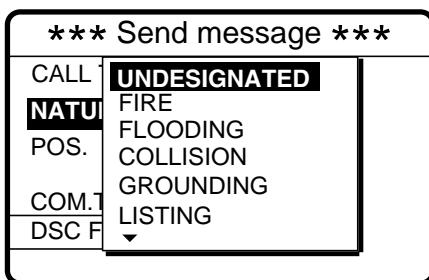

Use ▼ to scroll menu.

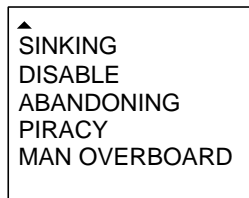

- Use ▲ or ▼ to select nature of distress and press the [ENT] key.
- Press the [ENT] key to open the POS. menu. This is where you enter your position, automatically or manually. If the positioning device is connected, INPUT TYPE is AUTO and the position is correct, press the [ENT] key twice and go to step 12. Note that “INPUT TYPE: MANUAL” appears when position is input manually.

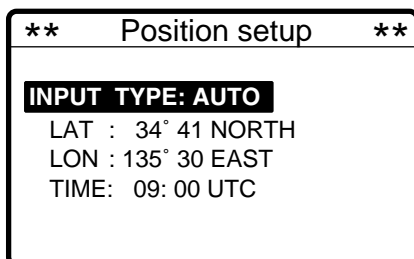

**Note:** If the message “NO POSITION DATA” appears when you change INPUT TYPE from MANUAL to AUTO, confirm the navigation device and select AUTO again.

4. Press the [ENT] key to open the INPUT TYPE menu.

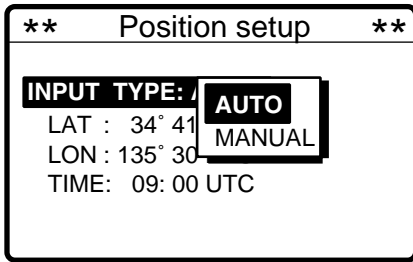

5. Press ▼ to select MANUAL and press the [ENT] key.  
6. Press the [ENT] key to open the latitude entry window.

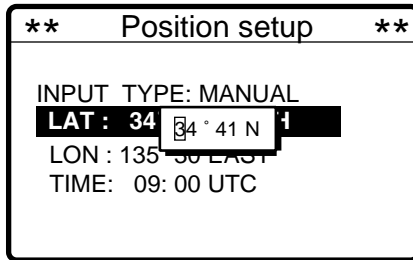

**Note:** Use ▼ to switch from North to South and vice versa.

7. Key in latitude in four digits and press the [ENT] key.  
8. Press the [ENT] key to open the longitude entry window.

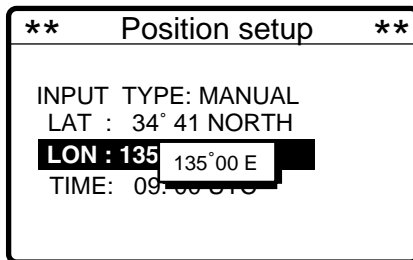

**Note:** Use ▼ to switch from East to West and vice versa.

9. Key in longitude in five digits and press the [ENT] key.  
10. Press the [ENT] key to open the time entry window.

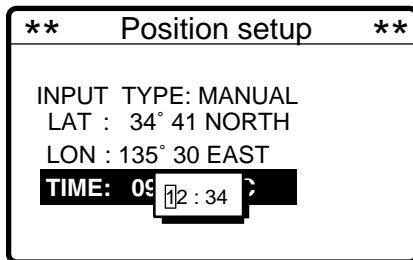

11. Key in UTC time and press the [ENT] key.

12. The SEND MESSAGE screen is redisplayed. Press the [ENT] key to open the COM. TYPE menu.

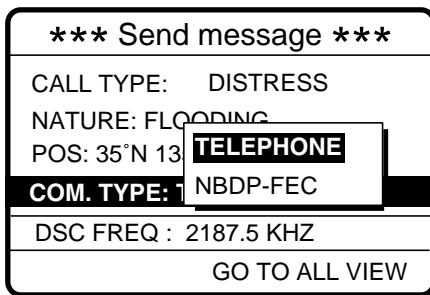

13. Select TELEPHONE and press the [ENT] key. (Telephone is the usual mode, however NBDP may also be used.)
14. Press the [ENT] key to open the DSC FREQ menu.

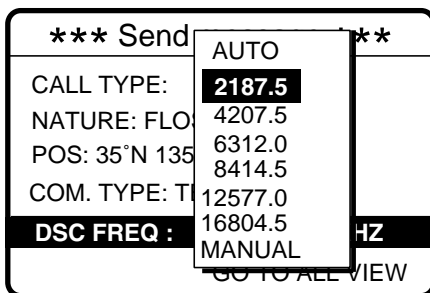

15. Select a DSC frequency (normally 2187.5 kHz) and press the [ENT] key. (AUTO retransmits the distress alert on 2 MHz, 8 MHz, 16 MHz, 4 MHz, 6 MHz and 2 MHz in sequence if the distress alert is not acknowledged and MANUAL is for manual selection of frequency at the radiotelephone when there is “remote error.”)

DSC	SSB radiotelephone	NBDP-FEC
2187.5 kHz	2182.0 kHz	2174.5 kHz
4207.5 kHz	4125.0 kHz	4177.5 kHz
6312.0 kHz	6215.0 kHz	6268.0 kHz
8414.5 kHz	8291.0 kHz	8376.5 kHz
12577.0 kHz	12290.0 kHz	12520.0 kHz
16804.5 kHz	16420.0 kHz	16695.0 kHz

16. The display changes as below.

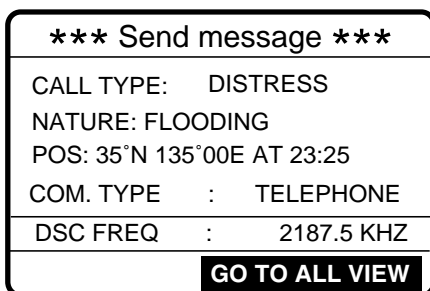

17. Press the [DISTRESS] button more than three seconds to send the distress alert.

Distress call in progress!	
NATURE: FLOODING	
POS: 12°34N 123°45E AT 12:34	
TELEPHONE	2182.0 KHZ
DSC FREQ :	2187.5 KHZ
TIME TO GO :	38S

18. Follow steps 3-6 on page 3-2 and 3-3.

## 3.2 Receiving a Distress Alert

When you receive a distress call from a ship in distress the audio alarm sounds and the message "Distress call received." appears on the display. Press the [CANCEL] key to silence the audio alarm. Wait for the distress acknowledge from a coast station. If you do not receive the distress acknowledge from a coast station, which usually takes about three minutes from reception of a distress alert, follow the flow chart on the next page to determine if you should send the distress acknowledge to the ship in distress. Do not send the distress acknowledge immediately after first reception of a distress alert. If you do send the distress acknowledge, relay the distress alert to a coast station and be prepared to aid the ship in distress.

The procedure for relaying the distress alert depends on if the alert was received on MF or HF band.

### 3.2.1 Distress alert received on MF band

Do the following:

- Continue watching on 2182 kHz. Wait for coast station to acknowledge the distress call. Distress communications continues until "SEELONCE FINI" is announced.
- If you do not receive the distress acknowledge from a coast station, and your ship can aid the ship in distress, transmit the distress acknowledge to the ship in distress by radiotelephone, over the distress frequency used by the ship in distress.
- Relay the distress alert to a coast station.

## Procedure when distress alert is received

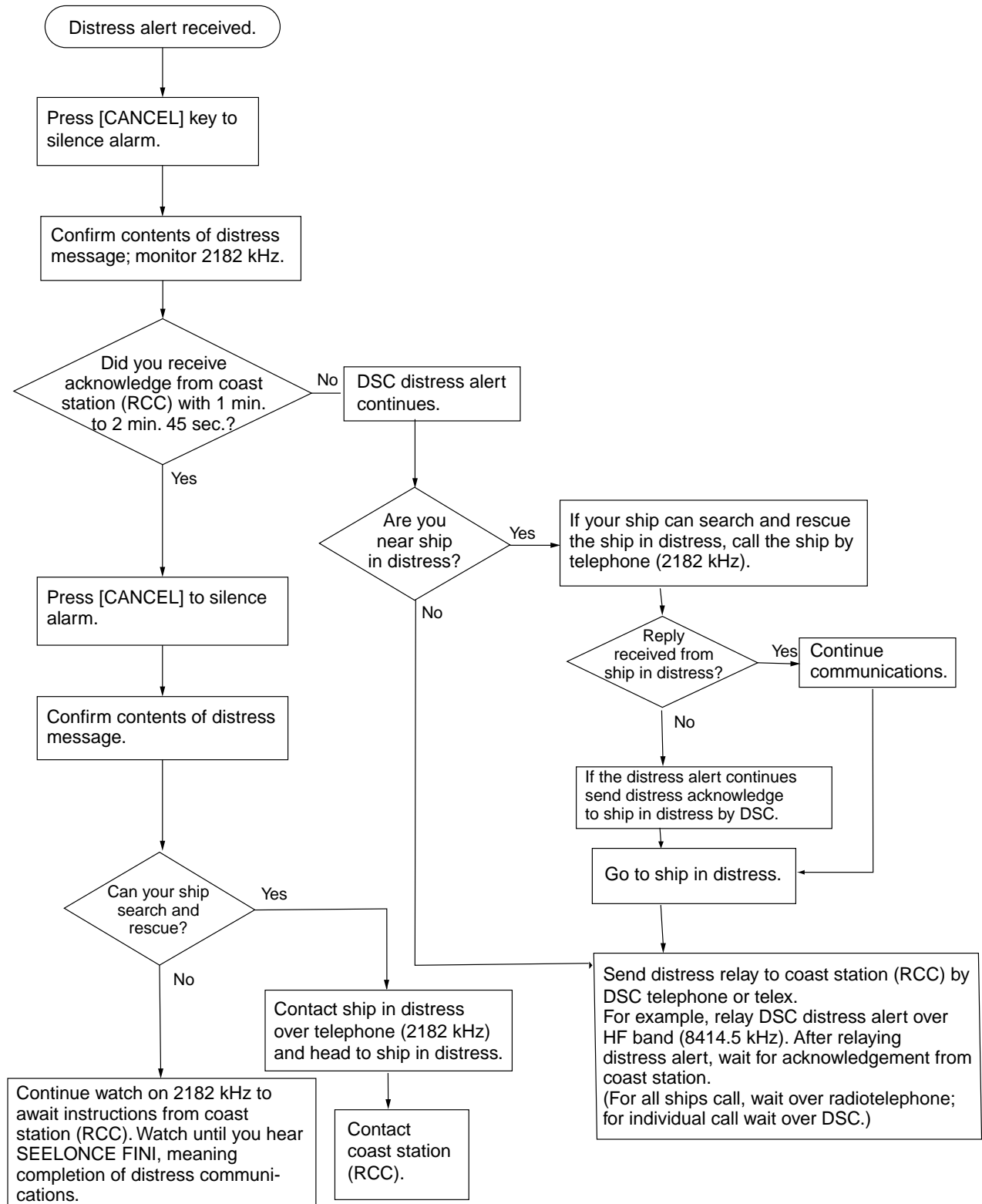

Note: If you receive a distress alert over HF band, wait five minutes. Then, only if you do not receive the distress acknowledge from a coast station, relay distress message to a coast station.

## Sending the distress relay to a coast station

First confirm whether your vessel should send the distress relay signal, by following the flow chart on page 3-8. If your ship meets those requirements do the following:

1. The audio alarm sounds and the display shows the message "Distress call received." when your ship receives a distress call.

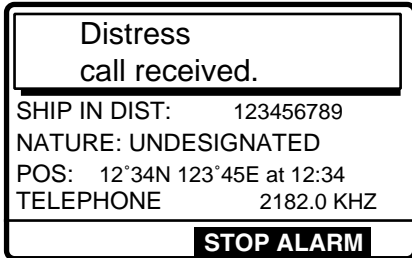

2. Press the [CANCEL] key to silence the audio alarm, and the display changes as below.

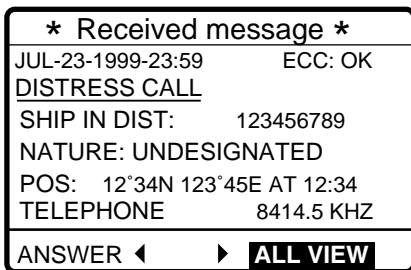

3. **Monitor the display for the distress acknowledge signal from the coast station. If you do not receive the distress acknowledge signal, and you have received the distress alert more than twice, press ◀ to choose ANSWER and press the [ENT] key.**
4. Press the [ENT] key to open the CALL TYPE menu.

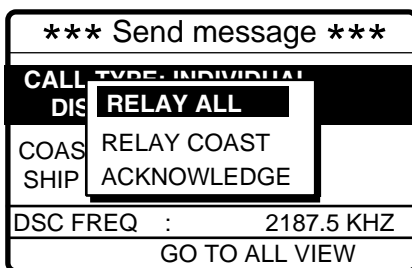

5. Select RELAY COAST (or RELAY ALL if you don't know the coast station where to send the distress relay) and press the [ENT] key. (For RELAY ALL go to step 7.) Press the [ENT] key to open the COAST ID entry window.

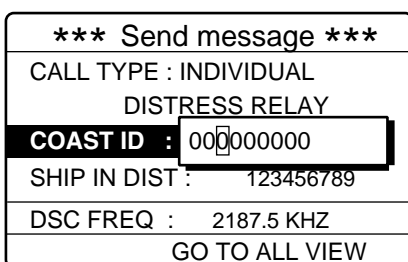

6. Key in coast ID where to send the distress relay and press the [ENT] key.
7. Press the [ENT] key to open the DSC FREQ. menu.

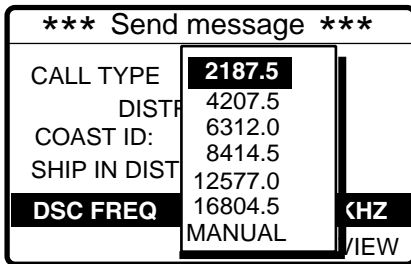

**MANUAL:** For manual selection of frequency at the radiotelephone when there is "remote control error."

8. Select appropriate frequency (first 8414.5 kHz) and press the [ENT] key.
9. Press the [CALL] key to relay the distress call.

**Note:** If a coast station acknowledges the distress alert call before the timer counts to zero, press the [CANCEL] key to cancel your call. Further, If the call key is pressed before five minutes has elapsed the time to wait until the distress relay is sent is shown at the bottom of the display.

10. While the distress relay sel call (to coast station) is being sent the display shows the following.

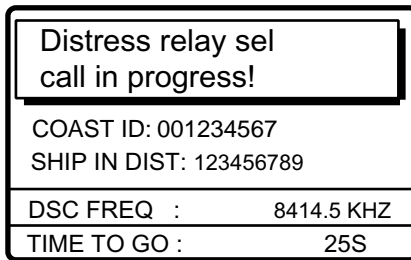

11. The equipment then waits for acknowledgement of the distress relay, showing the following. If the distress relay is not acknowledged within five minutes the message "No response. Try relay again." appears. If this occurs send the relay again.

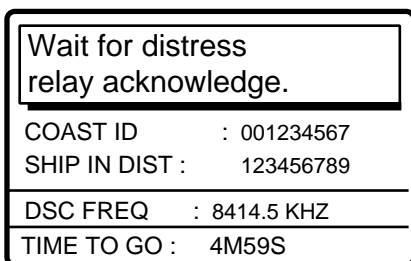

12. When the distress relay is acknowledged the audio alarm sounds and the display changes as below.

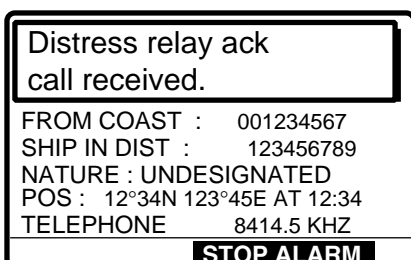



13. Press the [CANCEL] key to silence the audio alarm, and the display below appears.

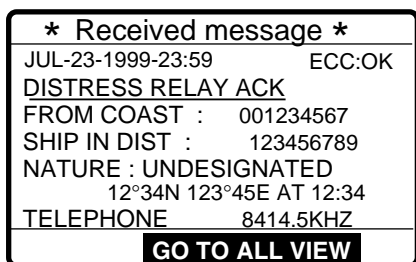

### Sending the distress acknowledge to ship in distress

Transmit the distress acknowledge signal to the ship in distress only when you do not receive it from a coast station and you are able to aid the ship in distress. First, transmit the distress acknowledge to the ship in distress by telephone. This will stop transmission of the distress alert.

1. The audio alarm sounds and the display shows the message "Distress call received." when your ship receives a distress call.

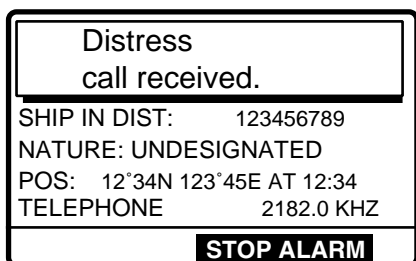

2. Press the [CANCEL] key to silence the audio alarm, and the display changes as below.

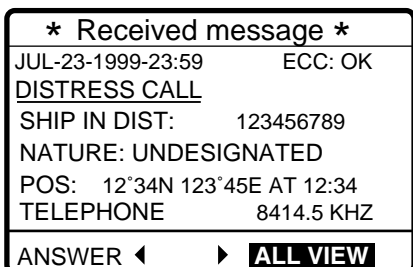

3. **If you do not receive the distress acknowledge from a coast station and you have received the distress alert more than twice**, press ◀ to choose ANSWER and press the [ENT] key to send the distress acknowledge signal to the ship in distress.
4. Press the [ENT] key to open the CALL TYPE menu.

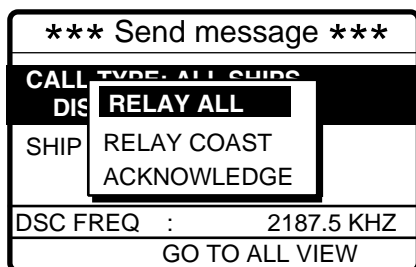

The option ACKNOWLEDGE does not appear in the following cases:

- a) Distress alert received on HF band.
- b) If, on MF band, more than 2 min. 45 sec. elapses after the distress alert is received.

5. Select ACKNOWLEDGE and press the [ENT] key. The following display appears.

*** Send message ***	
<b>CALL TYPE</b>	<b>: ALL SHIPS</b>
<b>DISTRESS ACKNOWLEDGE</b>	
SHIP IN DIST :	123456789
DSC FREQ : 2187.5 KHZ	
GO TO ALL VIEW	

6. Press the [CALL] key to send the distress acknowledge call to the ship in distress. Note that the distress acknowledge is immediately sent when the time elapsed between reception and transmission of it is more than one minute. If it is transmitted before one minute has elapsed a timer appears and counts down the time remaining before it is sent.

Distress acknowledge call in progress!	
SHIP IN DIST :	123456789
DSC FREQ : 2187.5 KHZ	
GO TO ALL VIEW	

### 3.2.2 Distress alert received on HF band

If you receive a distress signal on HF band, the ALARM lamp lights and the audio alarm sounds. Press the [CANCEL] key to silence the audio alarm. Wait for the distress acknowledge from a coast station. If you do not receive it within three minutes do one of the following:

- Watch on the distress frequency.
- Relay the distress alert in the following cases.
  - You do not receive distress acknowledge call from coast station within three minutes after receiving distress call.
  - You have not received distress relay from other ship.
  - You cannot receive distress communications from other ship over radiotelephone.

1. The audio alarm sounds and the display changes as below when a distress call is received.

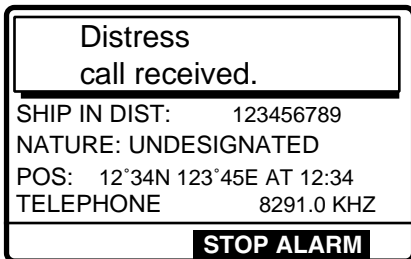

2. Press the [CANCEL] key to silence the audio alarm, and the display changes as below.



3. Press ◀ to choose ANSWER and press the [ENT] key.

4. Press the [ENT] key to open the CALL TYPE menu.

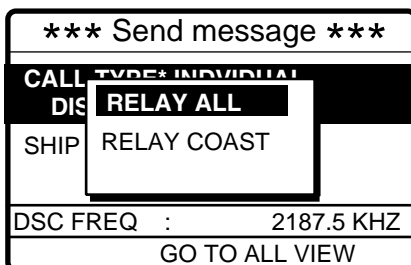

- Select RELAY COAST (if you know the ID of the nearest coast station) and press the [ENT] key.

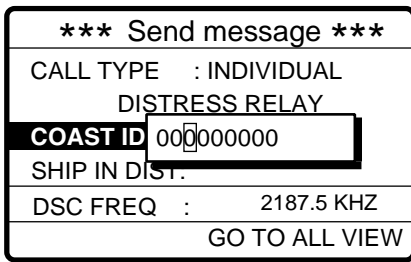

- Key in ID of coast station where to send the distress relay and press the [ENT] key.
- Press the [ENT] key to open the DSC FREQ. menu.

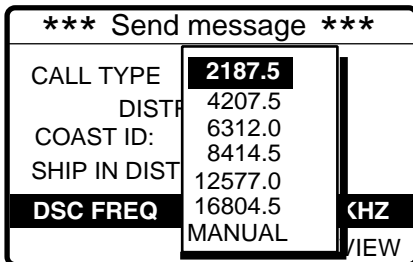

**MANUAL:** For manual selection of frequency at the radiotelephone when there is "remote control error."

- Select appropriate frequency and press the [ENT] key. You should first select 8414.5 kHz.
- Press the [CALL] key to relay the distress call.

**Note:** If a coast station acknowledges the distress alert call before the timer counts to zero, press the [CANCEL] key to cancel your call. Further, If the call key is pressed before five minutes has elapsed the time to wait until the distress relay is sent is shown at the bottom of the display.

- While the distress relay sel (to coast station) call is being sent the display shows the following.

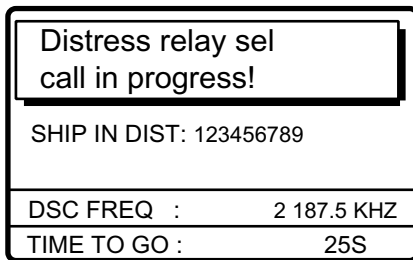

- After the call is transmitted the message "Wait for distress relay acknowledge!" appears. When you receive distress acknowledgement from the coast station communicate with the coast station by telephone, over the DSC frequency specified. If you do not receive the distress acknowledgement from a coast station after the timer counts down to zero, repeat the transmission on a different frequency.

### 3.3 Sending Distress Relay on Behalf of a Ship in Distress

#### 3.3.1 Sending distress relay to coast station

You may send the distress relay to a coast station on behalf of a ship in distress in the following cases:

- You are near the ship in distress and the ship in distress cannot transmit the distress alert.
- Another vessel requests you to transmit the distress relay.

***In these cases never use the [DISTRESS] button to transmit the distress relay.***

1. Press the [CALL] key and press the [ENT] key.

The screenshot shows a menu titled '\*\*\* Send \*\*\*'. The 'CALL TYPE' is set to 'INDIVIDUAL'. A sub-menu is open, listing options: PSTN CALL, TEST CALL, ALL SHIPS, GROUP CALL, AREA CALL, and POSITION. To the right, a separate box shows a scrollable list: POLLING, NEUTRAL, MEDICAL, RELAY ALL, RELAY SEL, and DISTRESS. An arrow points to 'RELAY SEL'.

If this part of the menu appears, use ▲ to scroll the menu.

2. Select RELAY SEL and press the [ENT] key. Press the [ENT] key to open the COAST ID entry window.

The screenshot shows a window titled '\*\*\* Send message \*\*\*'. The 'CALL TYPE' is 'RELAY SEL'. The 'COAST ID' field is highlighted with a cursor. Other fields include 'ID IN DIST' (00), 'NATURE: UNDESIGNATED', 'POS: 34°45N 15°', 'COM. TYPE: TELEPHONE', and 'DSC FREQ.: 2187.5 KHZ'. A 'GO TO ALL VIEW' button is at the bottom.

3. Key in COAST ID and ID and press the [ENT] key.
4. Press the [ENT] key to open the ID IN DIST window.

The screenshot shows a window titled '\*\*\* Send message \*\*\*'. The 'CALL TYPE' is 'RELAY ALL'. The 'ID IN DIST' field is highlighted with a cursor. Other fields include 'COAST ID', 'NATURE: UNDESIGNATED', 'POS.: : --N ---E', 'COM. TYPE: TELEPHONE', and 'DSC FREQ.: 2187.5 KHZ'. A 'GO TO ALL VIEW' button is at the bottom.

5. Key in ID of ship in distress and press the [ENT] key. If you do not know the ID leave the window blank.

6. Press the [ENT] key to open the NATURE menu.

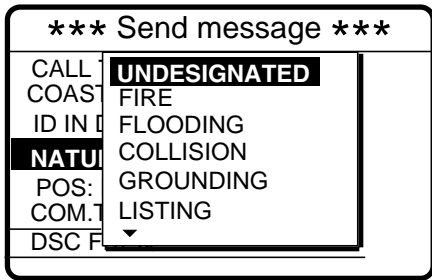

Use ▼ to scroll menu.

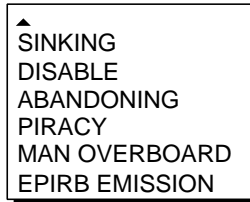

7. Select nature of distress and press the [ENT] key. (If you do not know the nature of distress, select UNDESIGNATED.) Press the [ENT] key to open the POS. menu.

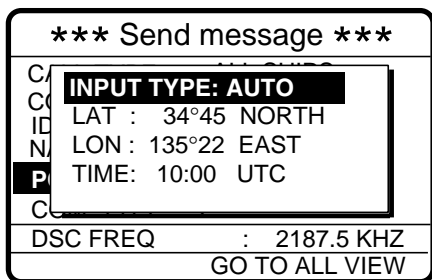

8. Enter position. For automatic input, press the [ENT] key twice. For manual, press the [ENT] key to select MANUAL and press the [ENT] key. Enter latitude, longitude of ship in distress and time as follows:

- a) Press ▼ to select LAT and press the [ENT] key. Enter latitude and press the [ENT] key.
- b) Press ▼ to select LONG and press the [ENT] key. Enter longitude and press the [ENT] key.
- c) Press ▼ to select TIME and press the [ENT] key. Enter UTC time and press the [ENT] key.

9. Press the [ENT] key to open the COM. TYPE menu.



10. Select TELEPHONE and press the [ENT] key. (NBDP may also be used.) Press the [ENT] key to open the DSC FREQ menu.

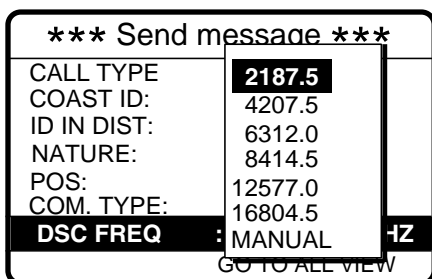

**MANUAL:** For selection of frequency at radiotelephone when there is "remote control error."

DSC	SSB radiotelephone	NBDP-FEC
2187.5 kHz	2182.0 kHz	2174.5 kHz
4207.5 kHz	4125.0 kHz	4177.5 kHz
6312.0 kHz	6215.0 kHz	6268.0 kHz
8414.5 kHz	8291.0 kHz	8376.5 kHz
12577.0 kHz	12290.0 kHz	12520.0 kHz
16804.5 kHz	16420.0 kHz	16695.0 kHz

11. Select appropriate DSC frequency and press the [ENT] key. The display now looks something like the one below.

*** Send message ***	
CALL TYPE :	RELAY SEL
COAST ID :	001234567
ID IN DIST :	NO INFO
NATURE :	SINKING
POS :	12°34N 123°45
COM. TYPE :	TELEPHONE
DSC FREQ :	2187.5 KHZ
<b>GO TO ALL VIEW</b>	

12. Press the [CALL] key to send the call.

Distress relay sel call in progress!	
TO COAST :	001234567
SHIP IN DIST :	NO INFO
POS :	12°34N 123°45 AT 12:34
TELEPHONE :	2182.0 KHZ
DSC FREQ :	2187.5 KHZ
TIME TO GO :	8S

13. The equipment then waits for acknowledgement of the distress relay, showing the following message. If the distress relay is not acknowledged within five minutes the message "No response. Try relay again." appears. If this occurs send the relay again.

Wait for distress relay acknowledge.	
FROM COAST:	001234567
SHIP IN DIST:	NO INFO
POS:	12°34N 123°45 AT 12:34
TELEPHONE:	2182.0 KHZ
DSC FREQ :	2187.5 KHZ
TIME TO GO :	4M59S

14. The audio alarm sounds and the display looks something like the one below when the distress relay acknowledge call is received.

Distress relay ack call received.	
FROM COAST :	001234567
SHIP IN DIST :	NO INFO
NATURE :	SINKING
POS :	12°34N 123°45 AT 12:34
TELEPHONE :	2187.5 KHZ
<b>STOP ALARM</b>	

15. Press the [CANCEL] key to silence the alarm. The following display appears.

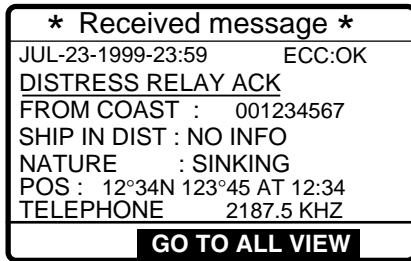

### 3.3.2 Sending distress relay to all ships

This procedure sends the distress relay to all ships

1. Press the [CALL] key .

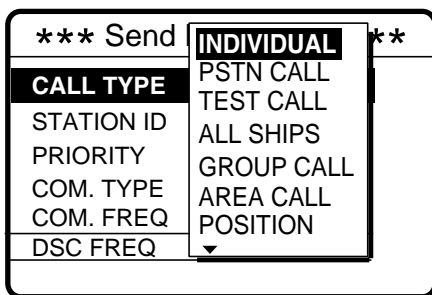

If this part of the menu appears, use ▲ to scroll the menu.

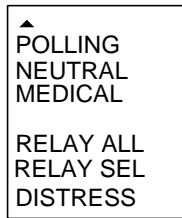

2. Select RELAY ALL and press the [ENT] key.

3. Press the [ENT] key to open the ID IN DIST menu.

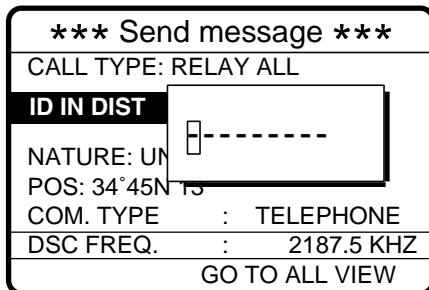

4. Key in ID of ship in distress (if known) and press the [ENT] key. (If you do not know the ID enter leave the ID menu as it is.

5. Press the [ENT] key to open the NATURE menu.

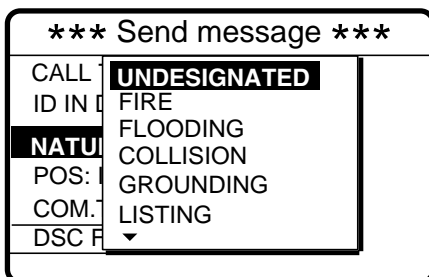

Use ▼ to scroll menu.

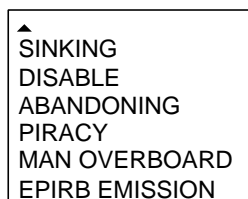



6. Select nature of distress (if known) and press the [ENT] key. (If you do not know the nature of distress, select UNDESIGNATED.)
7. Press the [ENT] key to open the POS. menu, where you enter the position of the ship in distress and time, manually or automatically.

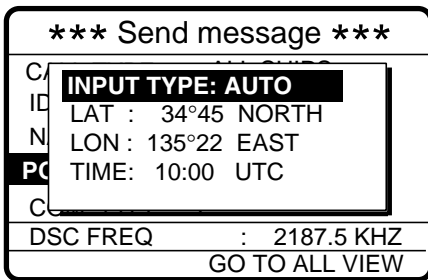

8. **To enter position and time automatically**, when you are near the ship in distress, press the [ENT] key, select AUTO, press the [ENT] key again and then go to step 9. **For manual input**, press the [ENT] key, select MANUAL and press the [ENT] key again. Enter position and time as follows:
  - a) Press ▼ to select LAT and press the [ENT] key. Enter latitude and press the [ENT] key.
  - b) Press ▼ to select LONG and press the [ENT] key. Enter longitude and press the [ENT] key.
  - c) Press ▼ to select TIME and press the [ENT] key. Enter UTC time and press the [ENT] key.
9. Press the [ENT] key to open the COM. TYPE menu.

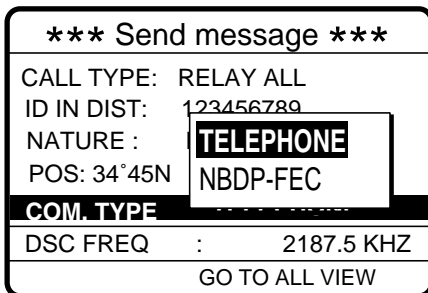

10. Select TELEPHONE and press the [ENT] key.
11. Press the [ENT] key to open the DSC FREQ menu.

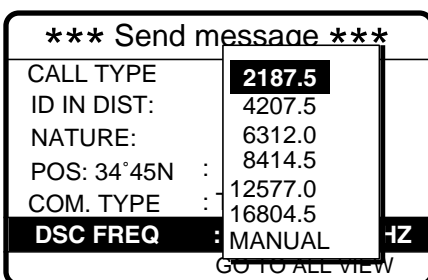

**MANUAL:** For selection of frequency at radiotelephone when there is "remote control error."

12. Select appropriate frequency and press the [ENT] key. The display now looks something like the one below.

*** Send message ***	
CALL TYPE:	RELAY ALL
ID IN DIST:	123456789
NATURE:	UNDESIGNATED
POS:	34°50N 135°45E AT 09:30
COM TYPE :	TELEPHONE
DSC FREQ :	2187.5 KHZ
<b>GO TO ALL VIEW</b>	

13. Press the [CALL] key to send the distress relay call (transmission time: about 40 sec.). The display shows the message "Distress relay all call in progress!".

**Note:** If a coast station acknowledges the distress alert call before the timer counts to zero, press the [CANCEL] key to cancel your call.

Distress relay all call in progress!	
SHIP IN DIST:	123456789
POS:	34°50N 135°45E AT 09:30
TELEPHONE	2182.0 KHZ
DSC FREQ :	2187.5 KHZ
TIME TO GO:	29S

14. After the call is sent the DSC standby screen automatically appears.

### 3.4 Receiving Distress Relay All Ships from Ship

When you receive a distress relay continue monitoring distress and safety frequencies over the SSB radiotelephone.

1. The audio alarm sounds and the display looks like the one below when a distress relay all ships call is received.

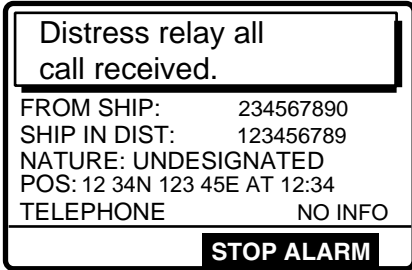

2. Press the [CANCEL] key to silence the alarm, and the display changes as below.



3. Watch distress/safety frequency.

### 3.5 Receiving Distress Relay from Coast Station

When you receive a distress relay continue monitoring distress and safety frequencies over the SSB radiotelephone.

1. The audio alarm sounds and the display looks like the one in the left-hand figure below when a distress relay is received from a coast station. Press the [CANCEL] key to silence the alarm, and the display changes as in the right-hand figure below.

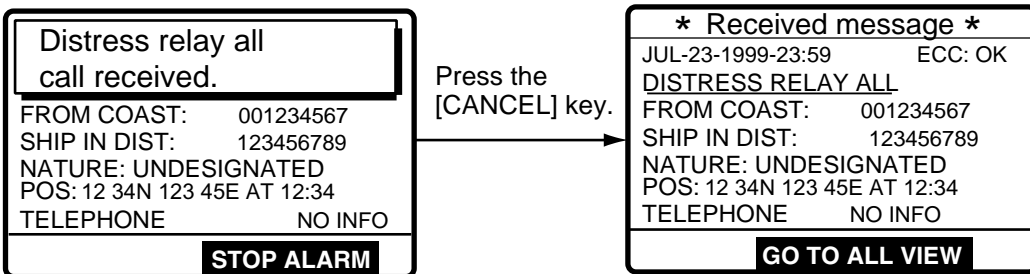

This page is intentionally left blank.

# 4. CALLING

This chapter provides the information necessary for general calling.

## 4.1 All Ships Call

When an urgent but not life endangering situation arises on your ship, for example, engine trouble, send an all ships call to request assistance.

After sending the message, you can communicate by voice over the radiotelephone. Do the following before beginning actual communications:

URGENCY priority: Say PAN three times followed by your call sign.

SAFETY priority: Say SECURITE three times followed by your call sign.

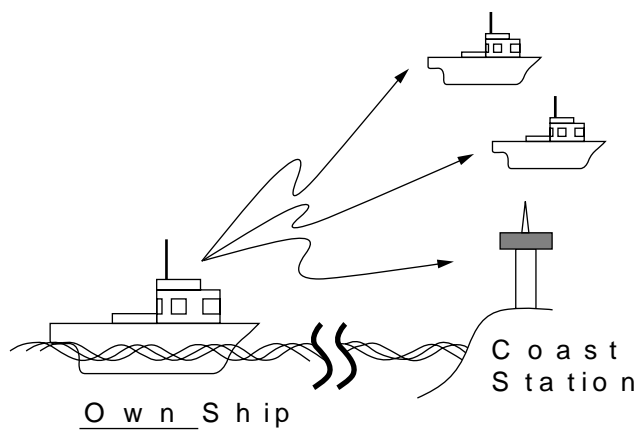

### 4.1.1 Sending all ships call

1. At the DSC standby screen, press the [CALL] key followed by the [ENT] key to display the CALL TYPE menu.

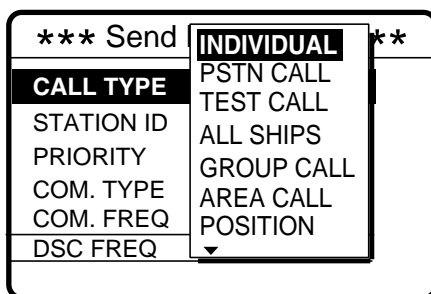

If this part of the menu appears, use ▲ to scroll the menu.

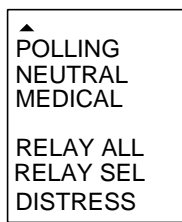

2. Use ▲ or ▼ to select ALL SHIPS and press the [ENT] key.

- Press the [ENT] key to display the PRIORITY menu.

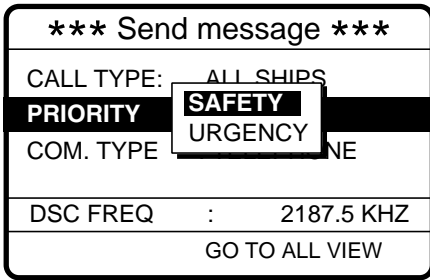

- Select SAFETY or URGENCY as appropriate and press the [ENT] key.
- Press the [ENT] key to open the COM. TYPE menu.

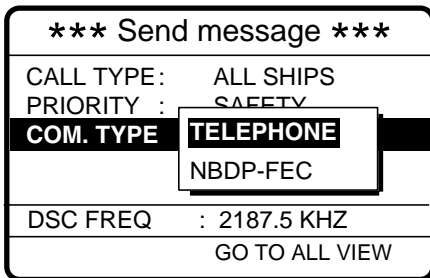

- Select communication type desired and press the [ENT] key.
- Press the [ENT] key to open the DSC FREQ menu.

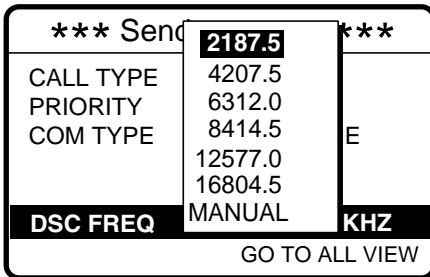

**MANUAL:** For manual selection of frequency at radiotelephone when there is "remote control error."

- Select frequency and press the [ENT] key.
- Press the [CALL] key to send the call (transmission time: about 7 sec.). The display shows "All ships call in progress!" while the call is being sent.

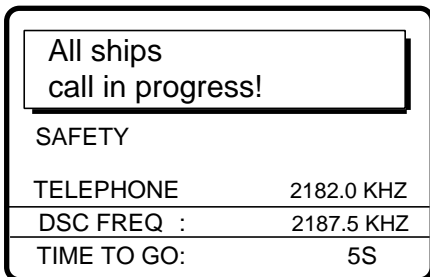

- The DSC standby screen automatically appears after the call is sent (timer counts down to zero). The equipment is set up for telephone (or NBDP) and safety or urgency priority, using DSC safety/urgency pair frequencies.

## 4.1.2 Receiving all ships call

1. When an all ships call is received the audio alarm sounds and the display looks something like the one shown below.

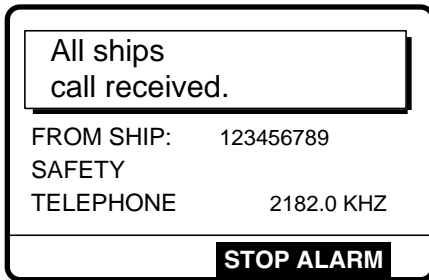

2. Press the [CANCEL] key to silence the alarm. The display shows partial contents of the all ships call as below.

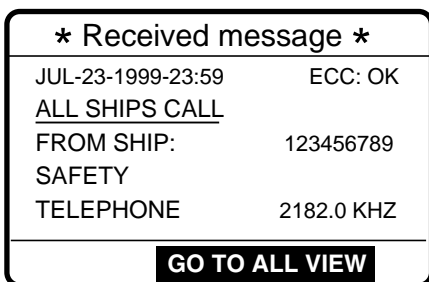

3. Press the [CANCEL] key again to return to the DSC standby screen. Watch for communications about all ships call on the DSC-60 or SSB radiotelephone.

## 4.2 Individual Call

The individual call is for sending a message to a specific station. After sending an individual message, called ACK RQ transmission, wait to receive the acknowledge back (ACK BQ) signal from the receiving station.

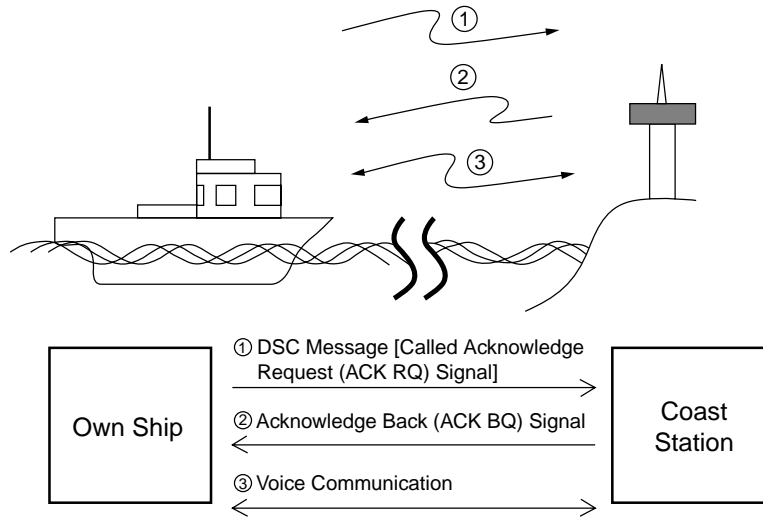

### 4.2.1 Sending individual call

- At the DSC standby screen, press the [CALL] key followed by the [ENT] key to open the CALL TYPE menu.

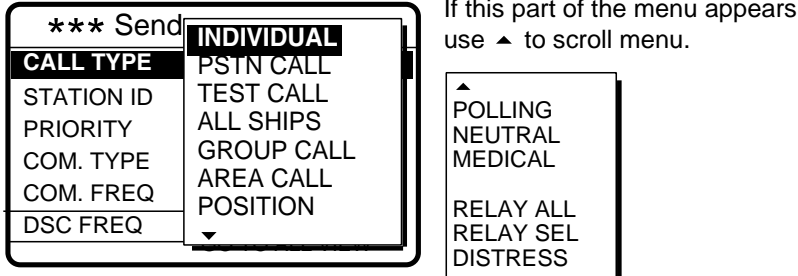

- Use ▲ or ▼ to select INDIVIDUAL and press the [ENT] key.
- Press the [ENT] key to open the STATION ID menu.

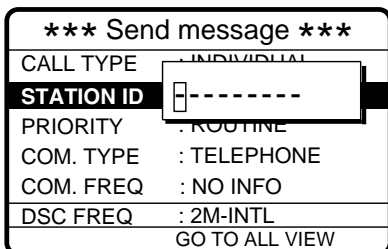

#### How to input station ID automatically

If you have registered some station IDs (see page 6-1), you can insert them into your message as follows:

- Press the [FILE] key after completing step 2 in the above procedure. The following display appears.

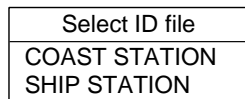

**Note:** You can print the Select ID file list by pressing the [8/PRINT] key.

- Select COAST STATION or SHIP STATION and press the [ENT] key.
- Select file which contains ID you want to use (press ▶ to show ID number).
- Press the [ENT] key to insert ID number in message.



- Key in ID of station where to send the message and then press the [ENT] key.
- Press the [ENT] key to open the PRIORITY menu.

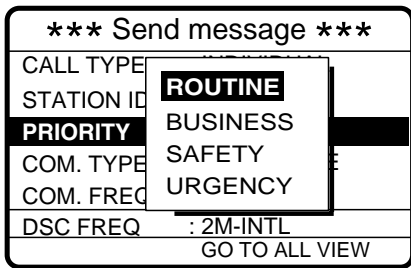

- Select appropriate priority (normally ROUTINE) and press the [ENT] key.
- Press the [ENT] key to open the COM. TYPE menu.

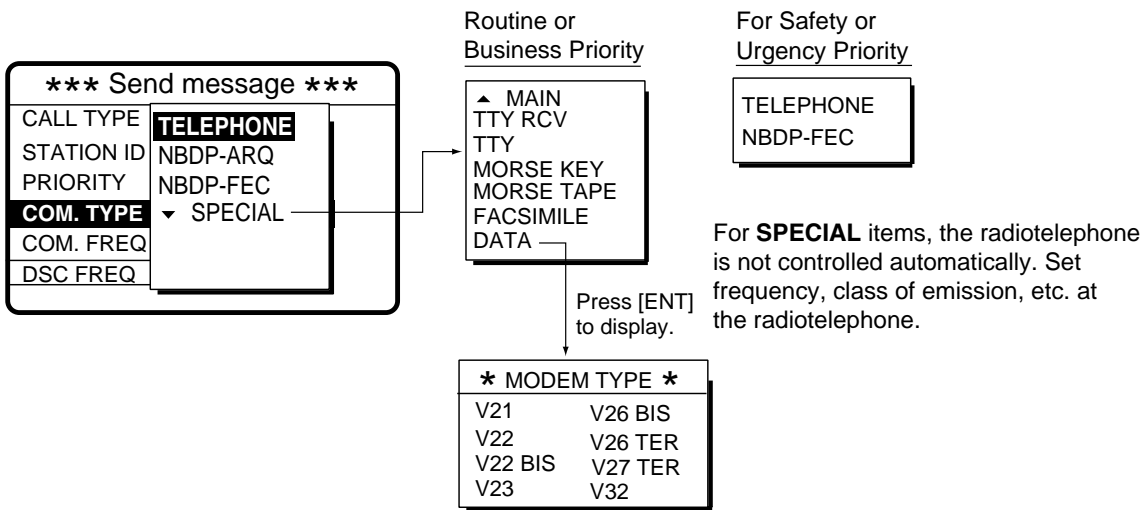

- Select communications type desired and press the [ENT] key.
- Press the [ENT] key to open the COM. FREQ menu.

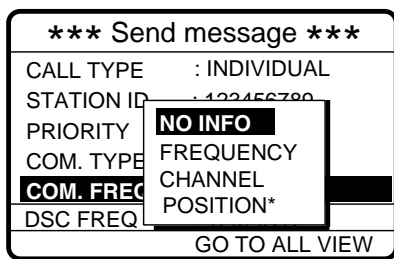

\* POSITION is displayed if a coast station is specified at step 3.

#### To select a user channel

If you have previously registered user channels (see page 7-10), you can insert one into your message as follows:

- Press the [FILE] key after completing step 8 in the above procedure. The following display appears.

User channel file	
00201. TX: 2301.0 RX: 2701.0	
00202. TX: 2302.0 RX: 2702.0	
00301. TX: 3301.0 RX: 3701.0	
00302. TX: 3302.0 TX: 3702.0	
▼UP ▲DOWN	

**Note:** You can print the User channel file list by pressing the [8/PRINT] key.

- Select file and press the [ENT] key to insert channel no. in message.

- Select item desired and press the [ENT] key. For FREQUENCY and CHANNEL see "How to Set Working Frequency" on the next page. NO INFO and POSITION lets the receiving station set the working frequency. Select NO INFO or POSITION to send message to a coast station. Select FREQUENCY or CHANNEL to send message to ship station.

## How to set working frequency

When you send a call set the working frequency as below to communicate with the receiver of the message. The working frequency can be entered by Tx and Rx and frequencies as below or channel no. as in "Channel" on the next page.

### Routine or ship's business priority

For FREQUENCY or CHANNEL follow one of the sections below.

#### *Frequency*

- a) Select FREQUENCY and press the [ENT] key.

TX:	0.0	KHZ
RX:	0.0	KHZ

- b) Key in Tx frequency in five or six digits with the numeric keys and press ▼. For example, enter 12329.0 kHz. If you make a mistake, press the [CANCEL] key and then reenter data.

TX:	12329.0	KHZ
RX:	0.0	KHZ

- c) Enter Rx frequency and press the [ENT] key. The Tx frequency entered appears in the COM. FREQ field.

<b>*** Send message ***</b>	
CALL TYPE:	INDIVIDUAL
STATION ID:	123456789
PRIORITY	: ROUTINE
COM. TYPE	: TELEPHONE
COM. FREQ	TX:12329.0 KHZ
<b>DSC FREQ</b>	<b>: 12M-INTL</b>
GO TO ALL VIEW	

## Channel

- a) Select CHANNEL and press the [ENT] key.
- b) Key in channel no. in four or five digits and press the [ENT] key. For example, enter CH 1201. Note that to enter user channel registered at Setup-user ch menu (page 7-11), press the [FILE] key at the COM. FREQ field and select a desired channel from the user channel file.

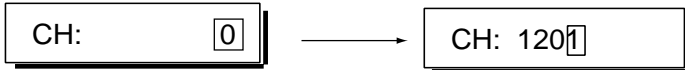

- c) The channel entered appears in the COM. FREQ field.

*** Send message ***	
CALL TYPE:	INDIVIDUAL
STATION ID:	123456789
PRIORITY	: ROUTINE
COM. TYPE	: TELEPHONE
COM. FREQ	: CH 1234
<b>DSC FREQ</b>	<b>: 12M-INTL</b>
GO TO ALL VIEW	

## Safety or urgency priority

For safety or urgency priority the communication frequency cannot be selected; it is automatically set to the pair frequency as set for the DSC frequency.

11. Press the [ENT] key to open the DSC FREQ menu. (The display below appears when routine or business priority is selected.)

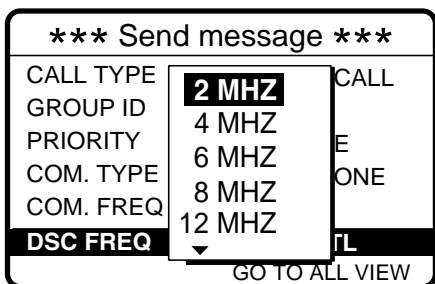

- ▲
- 16 MHZ
- 18 MHZ
- 22 MHZ
- 25 MHZ
- OTHER
- MANUAL

Use ▼ to scroll menu.

**OTHER:** Special, private channels.  
**MANUAL:** For selection of frequency at radiotelephone when there is "remote control error."

12. Select DSC frequency following the section below.

## How to set DSC frequency

### Routine or ship's business priority

a) Select DSC FREQ and press the [ENT] key.

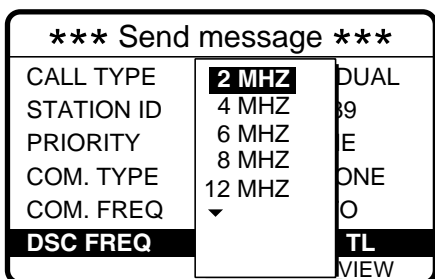

- ▲
- 16 MHZ
- 18 MHZ
- 22 MHZ
- 25 MHZ
- OTHER
- MANUAL

Use ▼ to scroll menu.

**OTHER:** Special, private channel  
**MANUAL:** Manual setting at radiotelephone

b) Select appropriate DSC band and press the [ENT] key. One of the menus shown on the next page appears depending on the band selected here.

**\*\*\* Send message \*\*\***

CALL TYPE    **2 MHz**

INTL        : T12577.5/R12657.0  
LOCAL1     : T12578.0/R12657.5  
LOCAL2     : T12578.5/R12658.0

▼

Use ▼ to scroll menu if user channels are registered.

▲

USER CH1 : T12345.0/R12345.0  
USER CH2 : T12345.5/R12345.5  
USER CH3 : T12346.0/R12346.0  
USER CH4 : T12346.5/R12346.5

LOCAL = Local channel

18MHz menu

INTL        : T18898.5/R19703.5  
LOCAL1     : T18899.0/R19704.0  
LOCAL2     : T18899.5/R19704.5

2MHz menu

INTL        : T 2189.5/R 2177.0

8MHz menu

INTL        : T 8415.0/R 8436.5

LOCAL      : T 8415.5/R8437.0

LOCAL      : T 8416.0/R8437.5

22MHz menu

INTL        : T22374.5/R22444.0

LOCAL1     : T22375.0/R22444.5

LOCAL2     : T22375.5/R22445.0

4MHz menu

INTL        : T 4208.0/R 4219.5

LOCAL1     : T 4208.5/R 4220.0

LOCAL2     : T 4209.0/R 4220.5

12MHz menu

INTL        : T12577.5/R12657.0

LOCAL1     : T12578.0/R12657.5

LOCAL2     : T12578.5/R12658.0

25MHz menu

INTL        : T25208.5/R26121.0

LOCAL1     : T25209.0/R26121.5

LOCAL2     : T25209.5/R26122.0

6MHz menu

INTL        : T 6312.5/R 6331.0

LOCAL1     : T 6313.0/R 6331.5

LOCAL2     : T 6313.5/R 6332.0

16MHz menu

INTL        : T16805.0/R16903.0

LOCAL1     : T16805.5/R16903.5

LOCAL2     : T16806.0/R16904.0

Other menu

INTL        : T 458.5/R 458.5

- c) Select DSC frequency with ▲ or ▼ and press the [ENT] key. The display shows the DSC frequency band selected.

**\*\*\* Send message \*\*\***

CALL TYPE:    INDIVIDUAL  
STATION ID:    123456789  
PRIORITY      : ROUTINE  
COM. TYPE     : TELEPHONE  
COM. FREQ     : NO INFO

---

DSC FREQ     : 2M-INTL

**GO TO ALL VIEW**

Safety or urgency priority

For safety or urgency priority the field COM. FREQ is automatically set to the same pair frequency as the DSC frequency.

- a) Select DSC FREQ and press the [ENT] key.

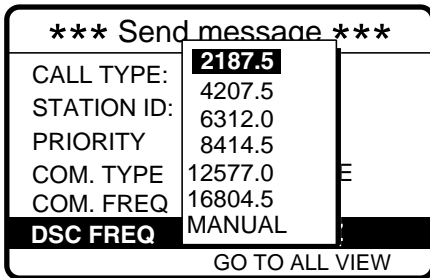

- b) Select appropriate frequency with ▼ or ▲ and press the [ENT] key.

13. Press the [CALL] key to send the message (transmission time: about 7 sec.). The display shows the message "Individual request call in progress!" while the message is being sent.

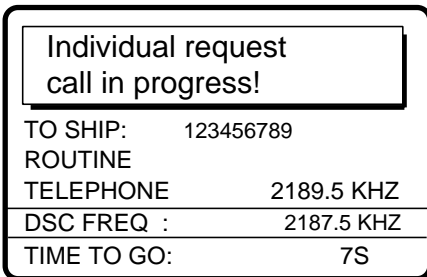

14. After the message is sent, the equipment waits for acknowledgement of the message, showing the display below.

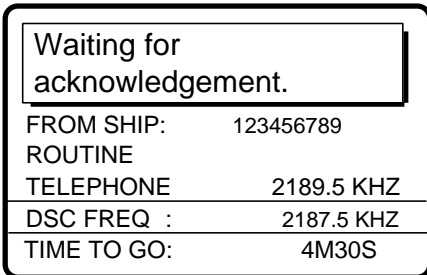

15. The timer starts counting down the maximum time to wait for acknowledgement, 3.5-4.5 minutes, randomly set. One of the following three messages appears. ("No response! Try calling again." appears after the timer counts down to zero. It means the station called did not respond.)

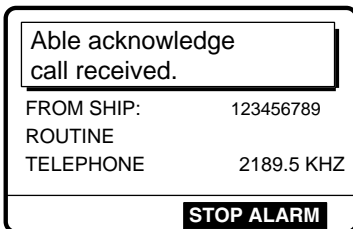

Able to acknowledge call received

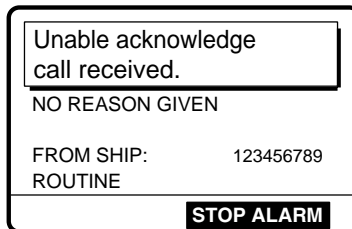

Unable to acknowledge call received

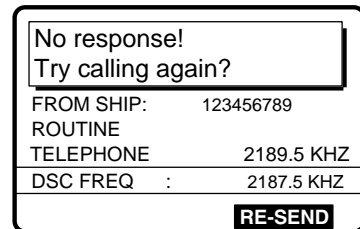

No response from station

16. Do one of the following depending on the message shown in step 15.

### Able acknowledge call received

The audio alarm sounds; press the [CANCEL] key to silence it. The display changes as below. Press the [CANCEL] key to return to the DSC standby screen. If you are using a FURUNO SSB radiotelephone the working frequency is automatically set; you may start communications. For other makes of radiotelephone set communication frequency and class of emission.

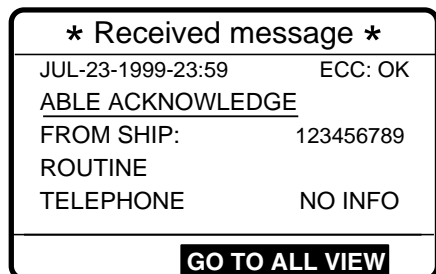

### Unable acknowledge call received

The alarm sounds; press the [CANCEL] key to silence the alarm, and the display looks something like the one below. Send the call again later. If the coast station sends the message "QUEUE INDICATION," wait until your turn arrives.

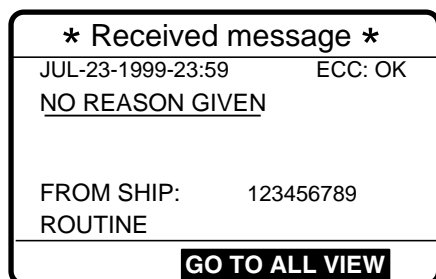

Reason for unable to acknowledge:  
NO REASON GIVEN  
CONGESTION AT SWITCHING CENTRE\*  
BUSY  
QUEUE INDICATION\*  
STATION BARRED\*  
NO OPERATOR AVAILABLE\*  
OPERATOR TEMPORARILY UNAVAILABLE\*  
EQUIPMENT DISABLED  
MODE NOT USABLE  
CHANNEL NOT USABLE

\* Coast station use

### No response! Try calling again?

**Re-send call:** Press the [ENT] key (the display shown in step 12 appears) followed by the [CALL] key

**Cancel call:** Press the [CANCEL] key to return to the DSC standby screen.

## 4.2.2 Receiving individual call

### Sending automatic acknowledge (ACK BQ) with comply type “ABLE”

When own ship receives an individual call you may or may not be able to receive the call depending on the comply type setting (on the Auto Ack menu) as below. The relationship between comply type and automatic/manual acknowledge is as below.

Comply type, automatic acknowledge	ABLE	UNABLE
AUTO ACK	Can send acknowledge automatically	Can send UNABLE automatically.
MANUAL ACK	Can send acknowledge manually	Can send UNABLE manually.

**Note:** The handset must be on hook to enable automatic acknowledge.

1. When an individual call is received and the automatic acknowledge feature is active and comply type is “ABLE”, the display shown below appears, indicating the auto acknowledge call (ACK BQ) call is being sent.

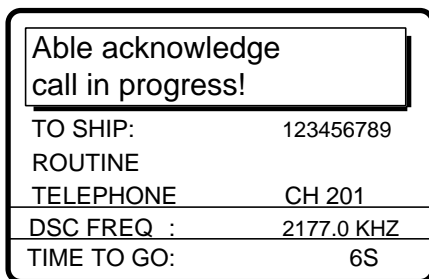

2. It takes about 7 sec. to transmit the call, after which the audio alarm sounds and the following message appears.

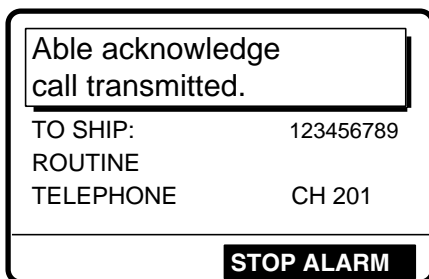

3. Press the [CANCEL] key to silence the alarm and the following display appears.



4. You can now communicate with party over frequency specified.



- If you want to re-send the message press ◀ to select RE-SEND and press the [ENT] key.

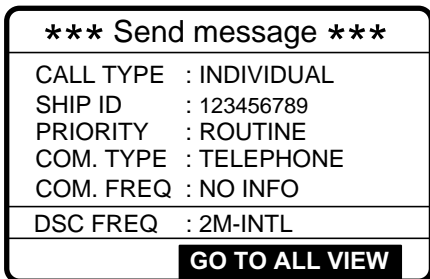

- Press the [CALL] key to re-send the call.

Sending automatic acknowledge (ACK BQ) with comply type “UNABLE”

- When an individual call is received and the automatic acknowledge feature and comply type is “UNABLE,” the display shown below appears, indicating the auto acknowledge call with UNABLE (ACK BQ) call is being sent.

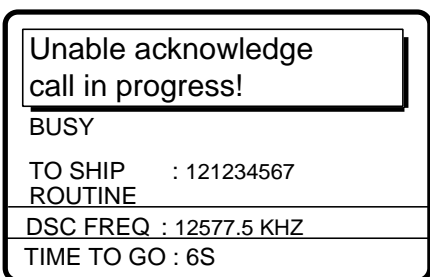

- It takes about 7 sec. to transmit the call, after which the audio alarm sounds and the following message appears.

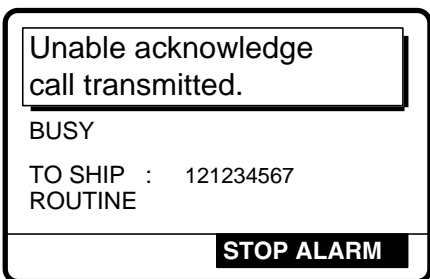

- Press the [CANCEL] key to silence the alarm and the following display appears.



- If you want to send a proposal, press ◀ to select RE-SEND and press the [ENT] key.

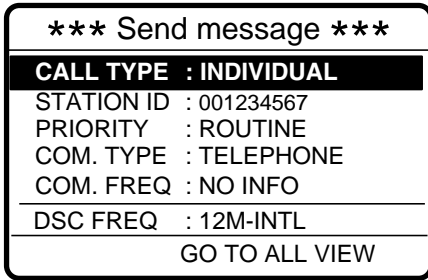

- Prepare individual message and press the [CALL] key to send. If the receiving station accepts your proposal, you can begin communications.

### Manually acknowledging individual call with "ABLE"

- When an individual call is received, the alarm sounds and the display looks like the one below.



- Press the [CANCEL] key to silence the alarm, and the display changes as shown below.



- Press ◀ to select "ANSWER" and then press the [ENT] key.

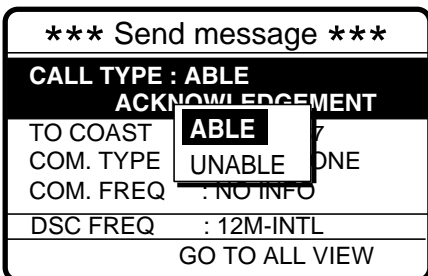

- Select ABLE and press the [ENT] key. The display changes as below. (IF ABLE is sent, working frequency is automatically set specified by other party.)

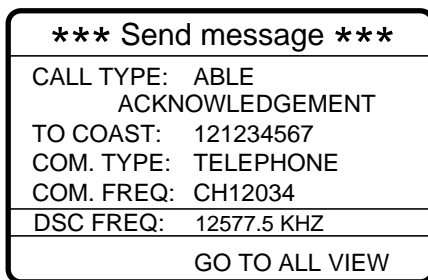

- Press the [CALL] key to send the call, and the display changes as below.

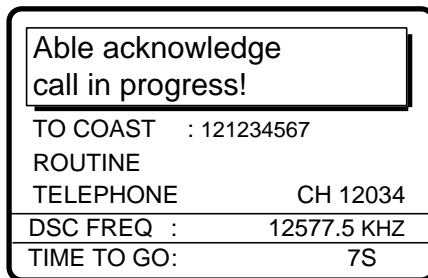

- After the call is sent (transmission time: 7 sec.), you can begin voice communications as soon as the message is completely transmitted.)

### Manually acknowledging individual call with "UNABLE"

- When an individual call is received the alarm sounds and the display shows the message "Individual request call received."



- Press the [CANCEL] key to silence the alarm, and the display changes as below.



- Press ◀ to select ANSWER and press the [ENT] key.

- Press the [ENT] key to open the CALL TYPE menu.

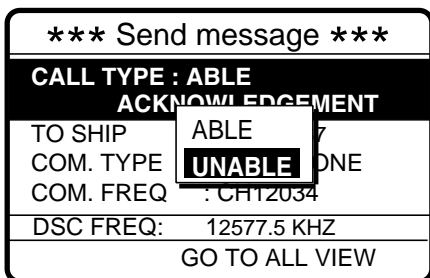

- Select UNABLE and press the [ENT] key.
- Press the [ENT] key. The display then prompts you for the reason you are unable to acknowledge.

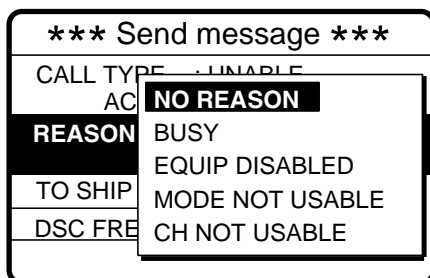

- Select suitable reason and press the [ENT] key.
- Press the [ENT] key to open the DSC FREQ menu. Select appropriate frequency and press the [ENT] key. The display changes as below.

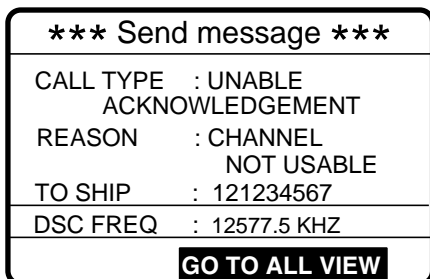

- Press the [CALL] key to send the call. The display shows "Unable acknowledge call in progress!" while the call is being sent.

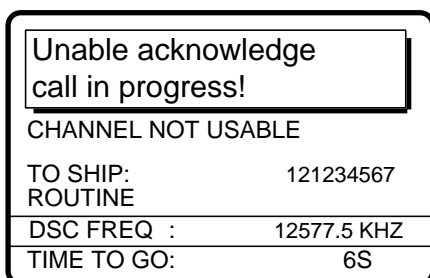

- The timer counts down the time remaining until the message is sent (transmission time: about 7 sec.). The DSC standby screen automatically appears upon completion of transmission.

## 4.3 Group Call

A group call is for calling a specific group by entering its group ID.

### 4.3.1 Sending a group call

1. Press the [CALL] key at the DSC standby screen, and press the [ENT] key to open the CALL TYPE menu.

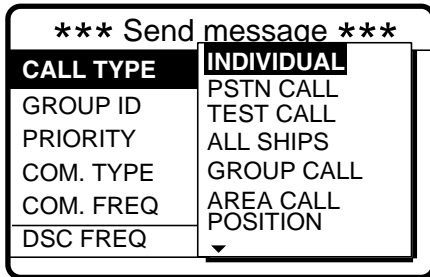

If this part of the menu appears use ▲ to scroll the menu.

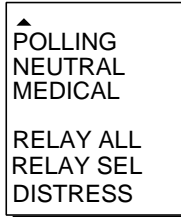

2. Use ▲ or ▼ to select GROUP CALL and press the [ENT] key.
3. Press the [ENT] key to open the GROUP ID menu.

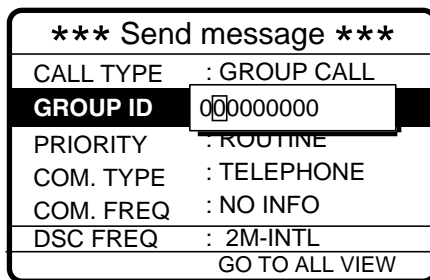

#### How to input group ID automatically

If you have registered some group IDs (see page 6-4), you can insert them into your message as follows:

1. Press the [FILE] key after completing step 2 in the above procedure. The following display appears.

Group ID file	
004. FURUNO	▶
500. MARINE	▶
777. ELECTRIC	▶
▲ UP	▼ DOWN

**Note:** You can print the Group ID file list by pressing the [8/PRINT] key.

2. Select file which contains ID you want to use (press ▶ to show ID number).
  3. Press the [ENT] key to insert ID number in message.
4. Key in group ID (nine digits) where to send the message and press the [ENT] key.
  5. Press the [ENT] key to open the PRIORITY menu.

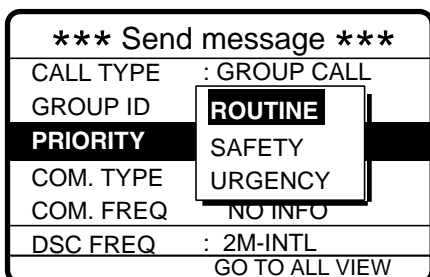

6. Select priority desired and press the [ENT] key.

7. Press the [ENT] key to open the COM. TYPE menu.

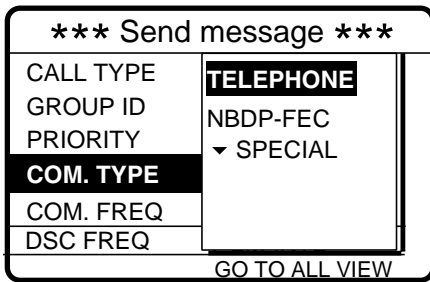

For Routine  
Use ▼ to scroll menu.



For Safety or Urgency



8. Select communication type desired and press the [ENT] key.

9. Press the [ENT] key to open the COM. FREQ menu.

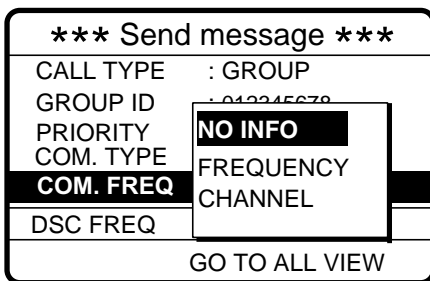

To select a user channel

If you have previously registered user channels (see page 7-10), you can insert one into your message as follows:

1. Press the [FILE] key after completing step 8 in the above procedure. The following display appears.

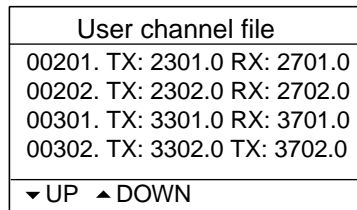

**Note:** You can print the User channel file list by pressing the [8/PRINT] key.

2. Select file and press the [ENT] key to insert channel no. in message.

10. Select communication frequency desired and press the [ENT] key. (See page 4-6 for details.)

11. Press the [ENT] key to open the DSC FREQ menu.

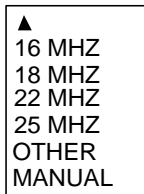
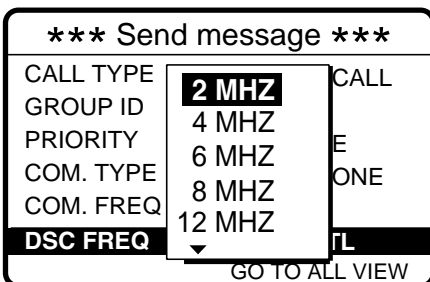

Use ▼ to scroll menu.

**OTHER:** Special, private channels.  
**MANUAL:** For selection of frequency at radiotelephone when there is "remote control error."

12. Select DSC band and then press the [ENT] key. Select DSC frequency and press the [ENT] key. (See page 4-8 for details.)

<b>*** Send message ***</b>	
CALL TYPE	: GROUP
GROUP ID	: 012345678
PRIORITY	: ROUTINE
COM. TYPE	: TELEPHONE
COM. FREQ	: 2164.0 KHZ
DSC FREQ	: 2177.0 KHZ
<b>GO TO ALL VIEW</b>	

13. Press the [CALL] key to send the group call (transmission time: about 7 sec.). The display shows "Group call in progress" while the call is being sent.

<b>Group call in progress!</b>	
GROUP ID	: 012345678
ROUTINE	
TELEPHONE	2164.0 KHZ
DSC FREQ	: 2177.0 KHZ
TIME TO GO	: 6S

14. The DSC standby screen automatically appears after the message is sent.

### 4.3.2 Receiving a group call

Group ID must be registered in order to receive a group call. See note on page 6-4.

1. The audio alarm sounds and the display shows "Group call received" when a group call is received.

<b>Group call received.</b>	
FROM SHIP:	123456789
ROUTINE	
TELEPHONE	2164.0 KHZ
<b>STOP ALARM</b>	

2. Press the [CANCEL] key to silence the alarm, and the display changes as below.

<b>* Received message *</b>	
JUL-23-1999-23:59	ECC: OK
<u>GROUP CALL</u>	
FROM SHIP :	123456789
ROUTINE	
TELEPHONE	2164.0 KHZ
<b>GO TO ALL VIEW</b>	

3. Press the [CANCEL] key to return to the DSC standby screen. Watch on the working frequency.

## 4.4 Geographical Area Call

The geographical area call sends a call to all ships within a specific area you designated in your geographical area call message. In the figure below, for example, the call will be sent to all ships within 10°S and 5°E of 34°N, 135°W.

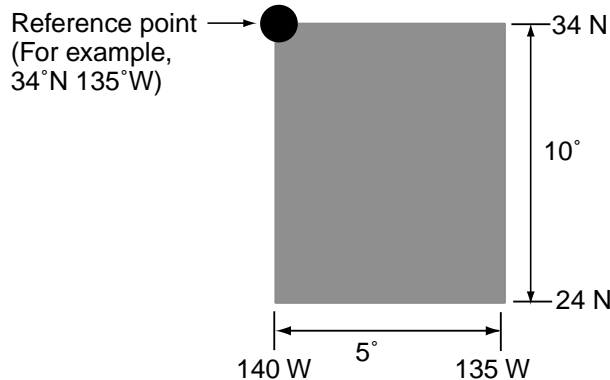

### 4.4.1 Sending a geographical area call

1. Press the [CALL] key at the DSC standby screen, and press the [ENT] key to open the CALL TYPE menu.

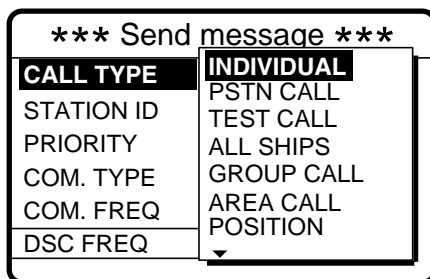

If this part of the menu appears use ▲ to scroll.

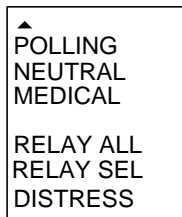

2. Use ▲ or ▼ to select AREA CALL and press the [ENT] key.
3. Press the [ENT] key to open the AREA menu.

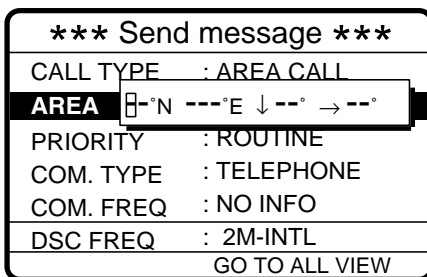

4. Enter latitude, longitude, southerly degrees and easterly degrees of area with the numeric keys and press the [ENT] key. Use ▲ or ▼ to switch from North to South latitude and vice versa and East to West longitude and vice versa.



- Press the [ENT] key to open the PRIORITY menu.

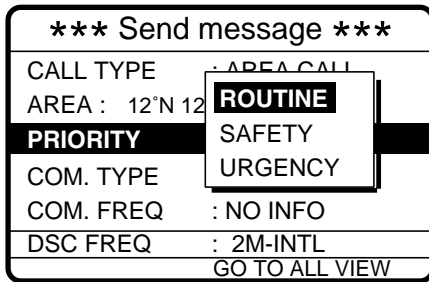

- Select priority desired and press the [ENT] key.
- Press the [ENT] key to open the COM. TYPE menu.

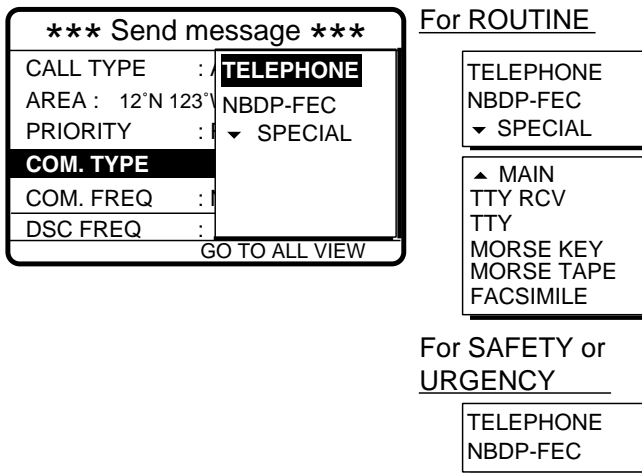

- Select communication type desired and press the [ENT] key.
- Press the [ENT] key to open the COM. FREQ menu.

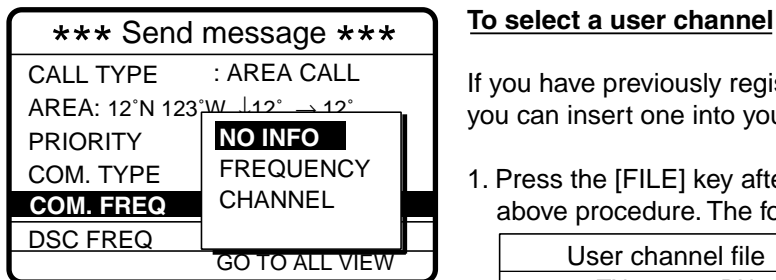

If you have previously registered user channels (see page 7-10), you can insert one into your message as follows:

- Press the [FILE] key after completing step 8 in the above procedure. The following display appears.

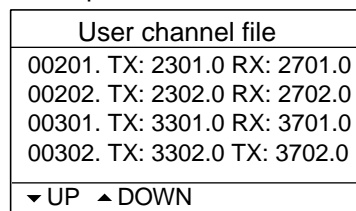

**Note:** You can print the User channel file list by pressing the [8/PRINT] key.

- Select file and press the [ENT] key to insert channel no. in message.

- Select communication frequency desired and press the [ENT] key. (See page 4-6 for details.)

11. Press the [ENT] key to open the DSC FREQ menu.

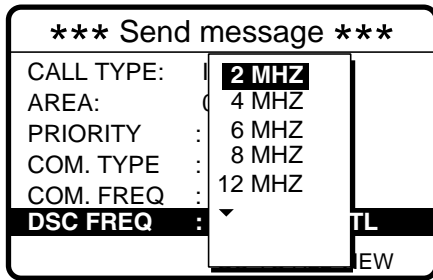

- ▲ 16 MHZ
- 18 MHZ
- 22 MHZ
- 25 MHZ
- OTHER
- MANUAL

Use ▼ to scroll menu.

**OTHER:** Special, private channels.  
**MANUAL:** For selection of frequency at radiotelephone when there is "remote control error."

12. Select DSC band and press the [ENT] key. Select DSC frequency and press the [ENT] key. (See page 4-8 for details.) Your display should now look something like one below.



13. Press the [CALL] key to send the geographical area call (transmission time: about 7 sec.). The display shows "Geographical area call in progress!" while the call is being sent.

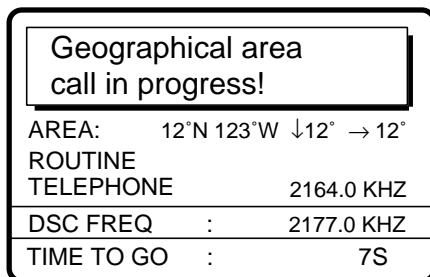

14. After the call is sent (timer counts down to zero), the DSC standby screen automatically appears. You can now communicate with other party.

## 4.4.2 Receiving a geographical area call

1. The alarm sounds and the display shows "Geographical area call received" when a geographical area call is received.

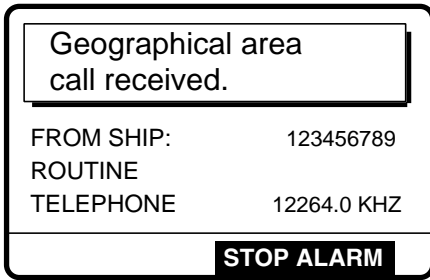

2. Press the [CANCEL] key to silence the alarm. The display changes as below.

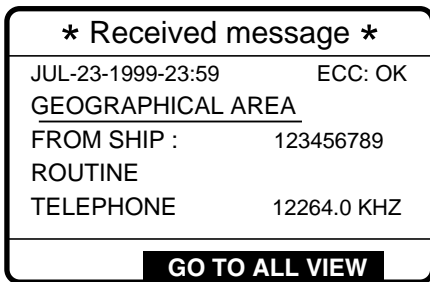

3. Press the [CANCEL] key at any time to return to the DSC standby screen. Watch on the working frequency specified in the geographic area call.

## 4.5 Neutral Craft Call

This type of call informs all ships that your ship is not a participant in armed conflict, and position and own ship ID are contained in the message. Send the call before entering an area of armed conflict.

### 4.5.1 Sending a neutral craft call

1. Press the [CALL] key followed by the [ENT] key to display the CALL TYPE menu.

*** Send r	
<b>CALL TYPE</b>	<b>POLLING</b>
STATION ID	NEUTRAL
PRIORITY	MEDICAL
DSC FREQ	RELAY ALL
	RELAY SEL
	DISTRESS

If this part of the menu appears use ▼ to scroll the menu.

INDIVIDUAL
PSTN CALL
TEST CALL
ALL SHIPS
GROUP CALL
AREA CALL
POSITION
▼

2. Use ▲ or ▼ to select NEUTRAL and press the [ENT] key.
3. Press the [ENT] key to open the PRIORITY menu.

*** Send message ***	
CALL TYPE	: NEUTRAL
<b>PRIORITY</b>	<b>SAFETY</b>
	URGENCY
COM. TYPE	: TELEPHONE
DSC FREQ	: 2187.5 KHZ
GO TO ALL VIEW	

4. Select appropriate priority and press the [ENT] key.
5. Press the [ENT] key to open the DSC FREQ menu.

**Note:** COM. TYPE is fixed at TELEPHONE.

*** Send	<b>2187.5</b>	***
CALL TYPE	4207.5	
	6312.0	
	8414.5	
PRIORITY	12577.0	
COM. TYPE	16804.5	
<b>DSC FREQ</b>	MANUAL	<b>KHZ</b>
GO TO ALL VIEW		

**MANUAL:** For selection of frequency at radiotelephone when there is "remote control error."

6. Select appropriate frequency and press the [ENT] key.

- The display changes as below. You are now ready to send the neutral craft call.

<b>*** Send message ***</b>	
CALL TYPE	: NEUTRAL CRAFT
PRIORITY	: SAFETY
COM. TYPE	: TELEPHONE
DSC FREQ	: 2187.5 KHZ
<b>GO TO ALL VIEW</b>	

- Press the [CALL] key to send the neutral craft call (transmission time: approx. 7 sec.).

Neutral craft call in progress!	
SAFETY	
TELEPHONE	2182.0 KHZ
DSC FREQ :	2187.5 KHZ
TIME TO GO:	7S

- After the call is sent (timer counts down to zero), the DSC standby screen automatically appears. Inform all ships (by radiotelephone) that your ship is not a participant in armed conflict.

#### 4.5.2 Receiving a neutral craft call

- When a neutral craft call is received the alarm sounds and the display changes as below.

Neutral craft call received.	
FROM SHIP:	123456789
SAFETY	
TELEPHONE	2182.0 KHZ
<b>STOP ALARM</b>	

- Press the [CANCEL] key to silence the alarm. The display changes as below.

<b>* Received message *</b>	
JUL-23-1999-23:59	ECC: OK
<u>NEUTRAL CRAFT</u>	
FROM SHIP:	123456789
SAFETY	
TELEPHONE	2182.0 KHZ
<b>GO TO ALL VIEW</b>	

## 4.6 Medical Transport Call

The medical transport call informs all ships, by using the priority "urgency", that own ship carries medical supplies.

### 4.6.1 Sending a medical transport call

1. Press the [CALL] key followed by the [ENT] key to open the CALL TYPE menu.

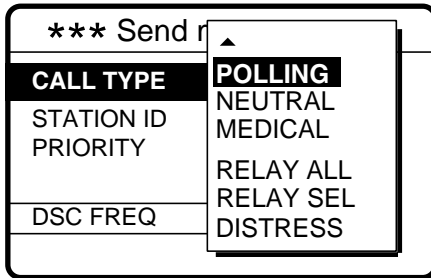

If the part of the menu appears, use ▼ to scroll menu.

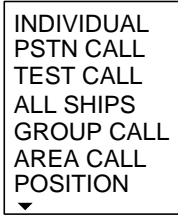

2. Use ▲ or ▼ to select MEDICAL and press the [ENT] key.

**Note:** PRIORITY and COM. TYPE are automatically selected to URGENCY and TELEPHONE, respectively.

3. Press the [ENT] key to open the DSC FREQ menu.

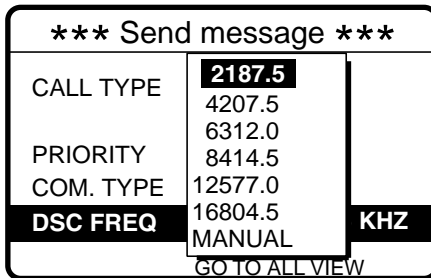

**MANUAL:** For selection of frequency at radiotelephone when there is "remote control error."

4. Select appropriate frequency and press the [ENT] key. The display changes as below.

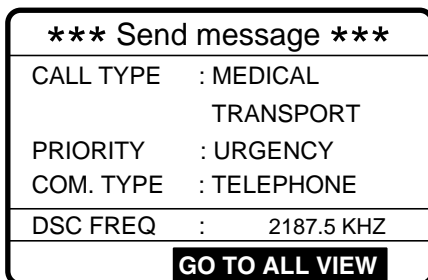

5. Press the [CALL] key to send the call (transmission time: about 7 sec.). The display shows "Medical transport call in progress!" while the message is being sent.

Medical transport call in progress!	
URGENCY	
TELEPHONE	2182.0 KHZ
DSC FREQ :	2187.5 KHZ
TIME TO GO :	7S

6. After the message is sent (timer counts down to zero) the DSC standby screen automatically appears. Inform all ships that your ship is transporting medical supplies.

## 4.6.2 Receiving a medical transport call

1. When a medical transport call is received, the alarm sounds and the display looks as below.

Medical transport call received.	
FROM SHIP:	123456789
URGENCY	
TELEPHONE	2182.0 KHZ
<b>STOP ALARM</b>	

2. Press the [CANCEL] key to silence the alarm. The display changes as below.

* Received message *	
JUL-23-1999-23:59	ECC: OK
<u>MEDICAL TRANSPORT</u>	
FROM SHIP:	123456789
URGENCY	
TELEPHONE	2182.0 KHZ
<b>GO TO ALL VIEW</b>	

## 4.7 Polling Call

Polling means confirming if own station is within communicating range with other station. This function only provides affirmative or negative response; it does not provide position information. Note that simultaneous polling to more than one station is not possible.

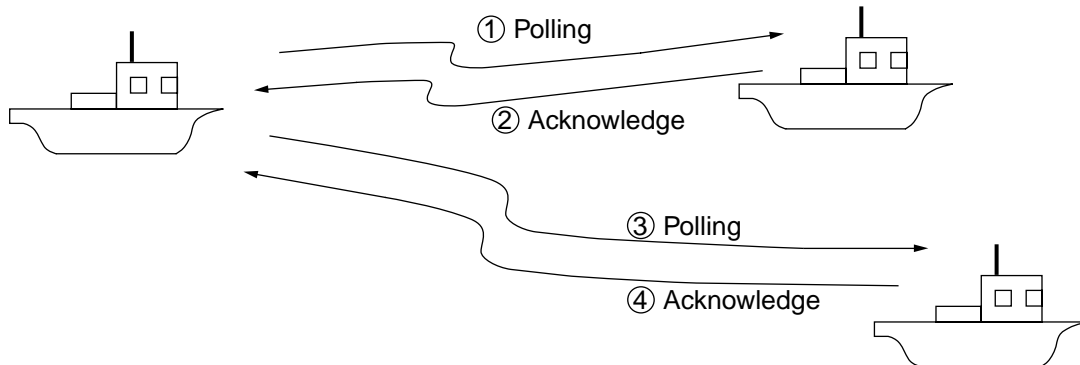

### 4.7.1 Sending a polling call

1. Press the [CALL] key followed by the [ENT] key to open the CALL TYPE menu.

*** Send message ***	
<b>CALL TYPE</b>	<b>POLLING</b>
STATION ID	NEUTRAL
PRIORITY	MEDICAL
DSC FREQ	RELAY ALL
	RELAY SEL
	DISTRESS

If the part of the menu appears, use ▼ to scroll menu.

INDIVIDUAL
PSTN CALL
TEST CALL
ALL SHIPS
GROUP CALL
AREA CALL
POSITION

2. Use ▲ or ▼ to select POLLING and press the [ENT] key.
3. Press the [ENT] key to open the STATION ID menu.

*** Send message ***	
CALL TYPE	: POLLING
<b>STATION ID</b>	<input style="width: 100px;" type="text" value="-----"/>
PRIORITY	: ROUTINE
DSC FREQ	: 2M-INTL
GO TO ALL VIEW	

4. Key in ID of station where to send call and press the [ENT] key.



- Press the [ENT] key to open the PRIORITY menu.

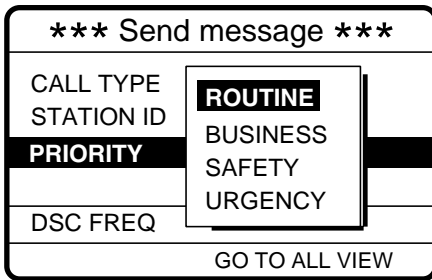

- Select priority desired (usually ROUTINE) and press the [ENT] key.
- Press the [ENT] key to open the DSC FREQ menu.

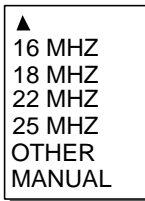
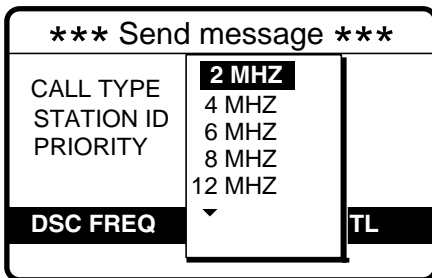

Use ▼ to scroll menu.

**OTHER:** Special, private channels.  
**MANUAL:** For selection of frequency at radiotelephone when there is "remote control error."

- Select appropriate DSC band and press the [ENT] key. Select DSC frequency and press the [ENT] key. The display changes as below.

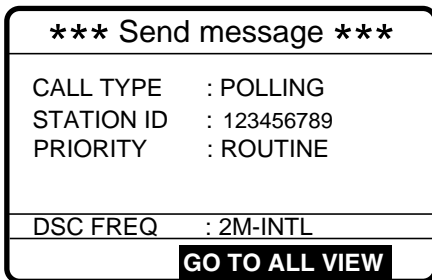

- Press the [CALL] key to send the call (transmission time: about 7 sec.), and the display changes as below.

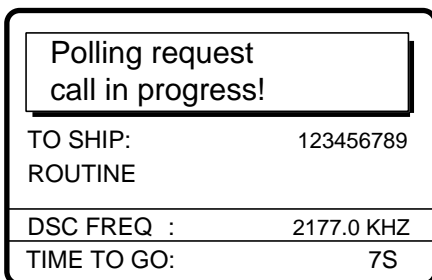

10. After the call is sent (timer counts down to zero) the following display appears.

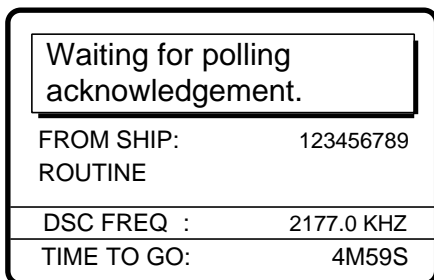

11. The timer counts down the time remaining to wait for acknowledgment of the call. One of the following displays appears. (“No response! Try calling again?” appears when there is no response from receiving station; timer counts down to zero.)

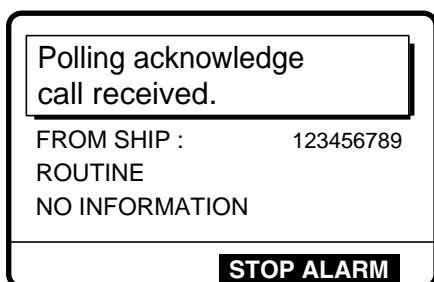

Polling acknowledge call received

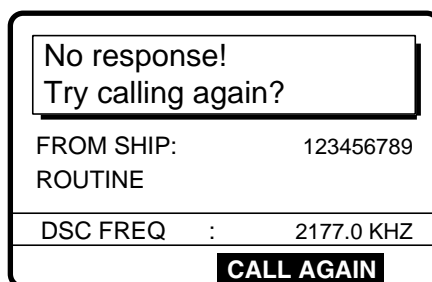

No response

12. Do one of the following depending on the message shown in step 11.

Polling acknowledge call received

The audio alarm sounds; press the [CANCEL] key to silence the alarm. The display changes as below. You can confirm if called party is within communicating range.

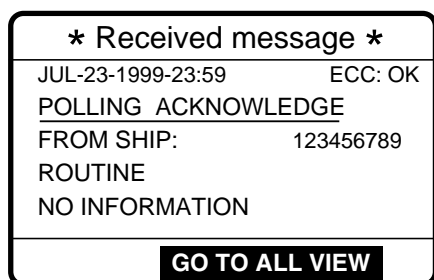

No response! Try calling again?

**Re-send call:** Press the [ENT] key (the display shown in step 8 appears), followed by the [CALL] key to re-send the call.

**Cancel call:** Press the [CANCEL] key to return to the DSC standby screen.

## 4.7.2 Receiving a polling call

### Automatic reply

1. The display changes as follows and the audio alarm sounds when a polling request call is received and the status of the [5/ACK] key is AUTO ACK and the setting of POLLING CALL on the Auto ack menu is ON.

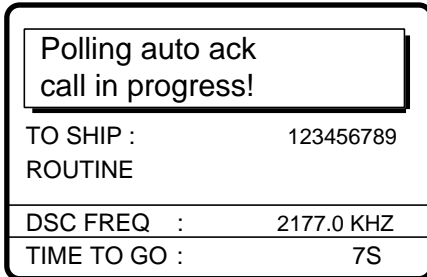

2. After the call is transmitted the following display appears and the audio alarm sounds.

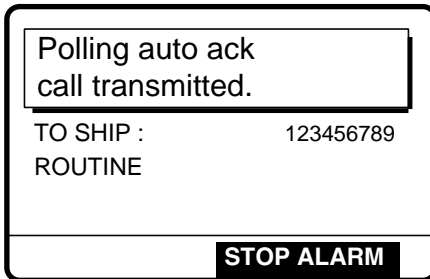

3. Press the [CANCEL] key to silence the alarm. The display changes as below.

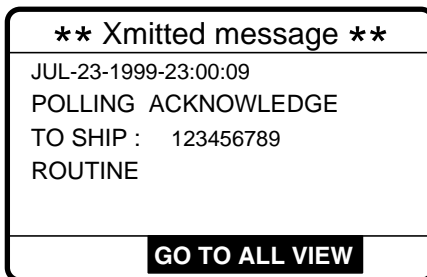

4. Press the [CANCEL] key to return to the DSC standby screen.

## Manual reply

1. The display changes as follows and the audio alarm sounds when a polling request call is received and the status of the [5/ACK] key is MANUAL ACK.



2. Press the [CANCEL] key to silence the alarm. The display changes as below.

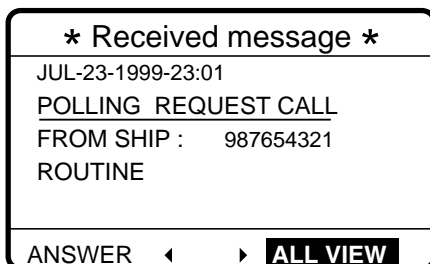

3. Press ◀ to select ANSWER and press the [ENT] key. The display changes as below.



4. Press the [CALL] key to send polling acknowledge call. The display changes as below.

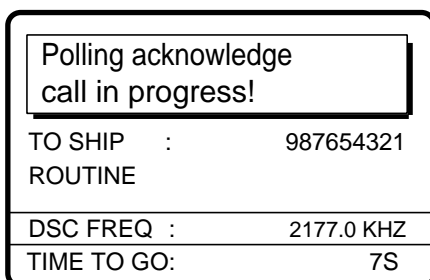

After the call is sent the DSC standby screen appears.

## 4.8 Position Call

There are two types of position calls: you send your position to other stations and your ship requests position of another ship.

### Sending own ship's position to other stations

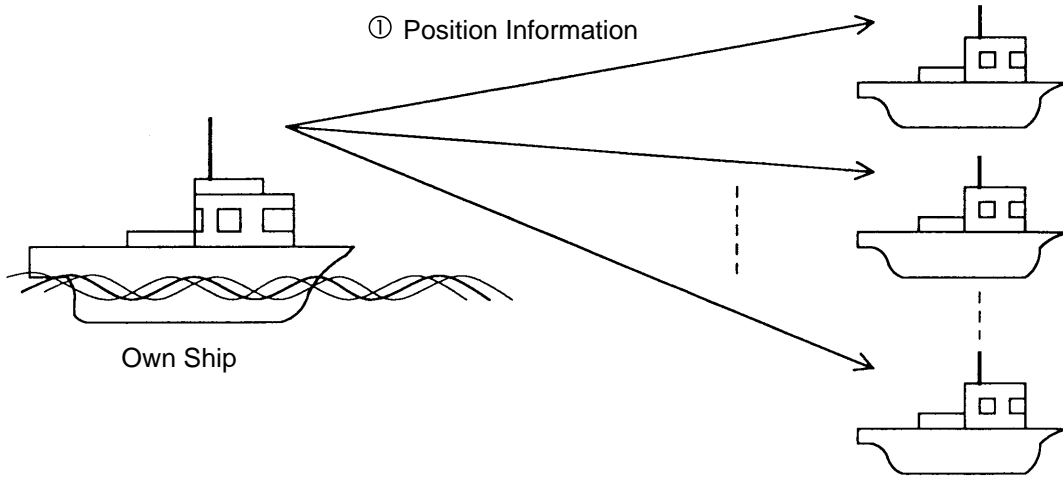

### Finding position of other station

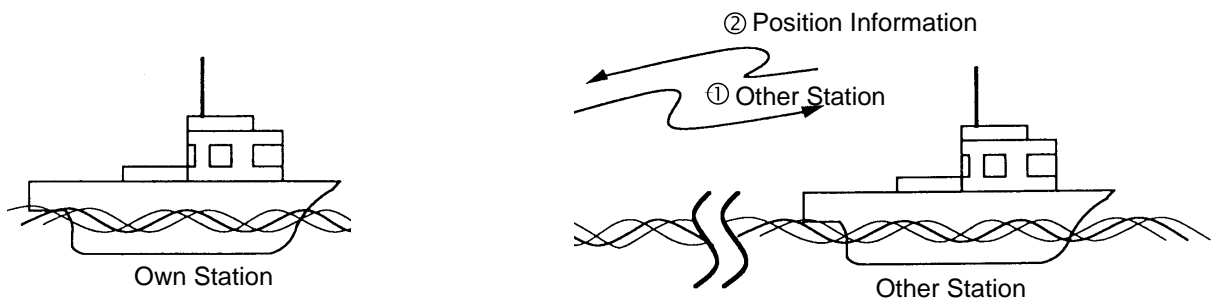

## 4.8.1 Position call: requesting other ship's position

1. Press the [CALL] key, and press the [ENT] key to open the CALL TYPE menu.

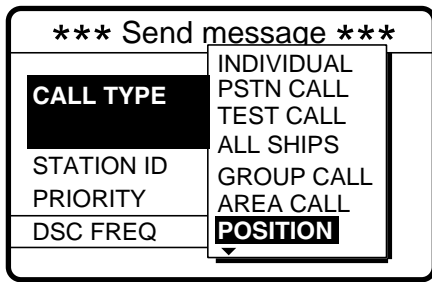

If this part of menu appears, use ▲ to scroll menu.

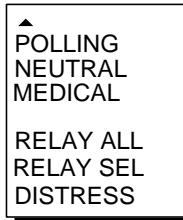

2. Use ▲ or ▼ to select POSITION and press the [ENT] key.
3. Press the [ENT] key to open the STATION ID menu.

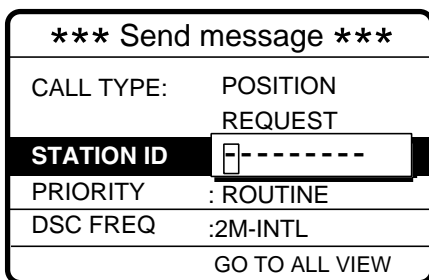

4. Key in ID of station (nine digits) of which you want their position and press the [ENT] key.
5. Press the [ENT] key to open the PRIORITY menu.

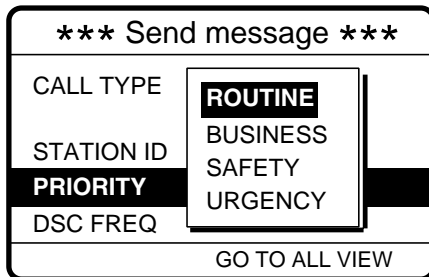

6. Select priority desired (usually ROUTINE) and press the [ENT] key.
7. Press the [ENT] key to open the DSC FREQ menu.

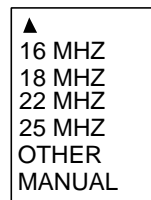
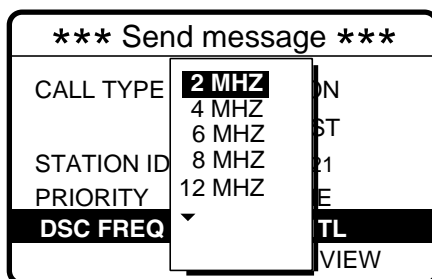

Use ▼ to scroll menu.

**OTHER:** Special, private channels.  
**MANUAL:** For selection of frequency at radiotelephone when there is "remote control error."

8. Select appropriate DSC band and press the [ENT] key. Select DSC frequency and press the [ENT] key. (See page 4-8 for details.)

9. The display now looks something like the following.

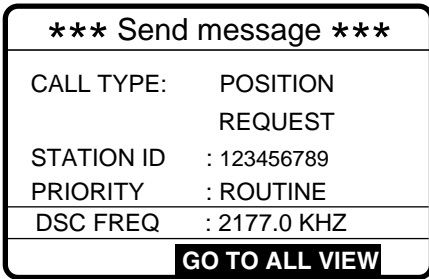

10. Press the [CALL] key to send the call (transmission time: about 7 sec.). The following display appears.

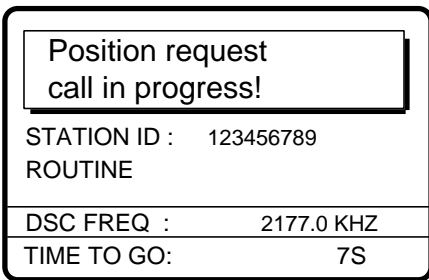

11. After the call has been sent (the timer counts down to zero) the following display appears.

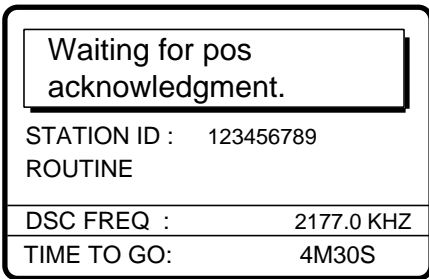

12. One of the following messages appears. (“No response! Try calling again?” appears after the time has counted down to zero, meaning there is no response from the receiving station.)



Position acknowledge call received

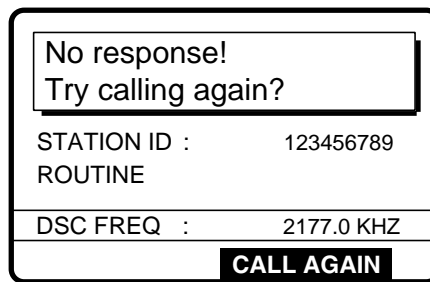

No response

13. Do one of the following depending on the message displayed at step 12.

### Acknowledge call received

The audio alarm sounds; press the [CANCEL] or [ENT] key to silence the alarm. The display looks as below. You can now confirm position of other ship.

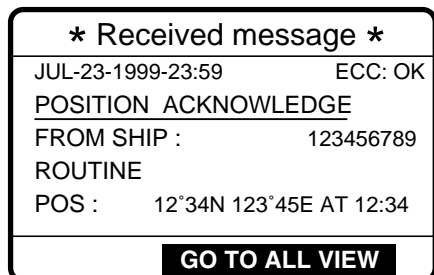

### No response! Try calling again?

**Re-send call:** Press the [ENT] key (the display shown in step 9 appears) followed by the [CALL] key.

**Cancel call:** Press the [CANCEL] key.

## 4.8.2 Position call: other ship requests your position

### Automatic reply

1. The display changes as below when another ship requests your position and the status of the [5/ACK] key is AUTO ACK and the setting of POSITION CALL on the Auto ack menu is ON.

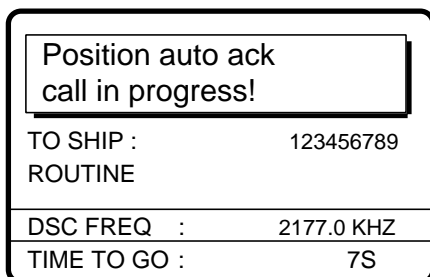

2. After the call is sent (transmission time: approx. 7 sec.) the audio alarm sounds and the display below appears.

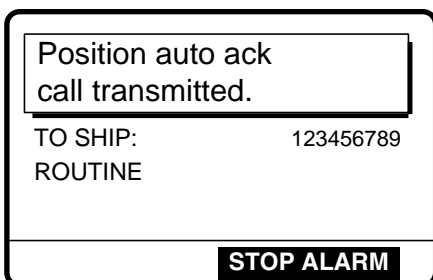



- Press the [CANCEL] key to silence the alarm, and the display changes as below.

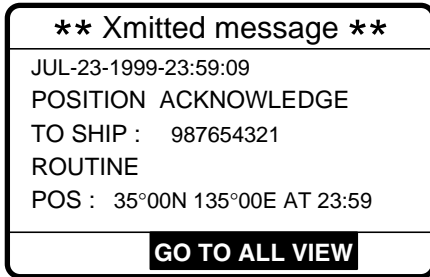

- Press the [CANCEL] key to return to the DSC standby screen.

### Manual reply

- When a position request call is received and the status of the [5/ACK] key is MANUAL ACK the audio alarm sounds and the display changes as below.



- Press the [CANCEL] key to silence the alarm. The display changes as below.



- If you want to send your position to another ship, press < to select ANSWER and press the [ENT] key. Your display should now look something like the one below.

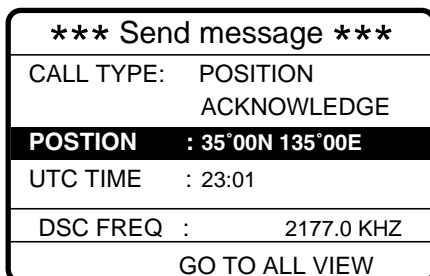

4. Confirm your position and then press the [CALL] to send the call (transmission time: approx. 7 sec.). The display changes as below.

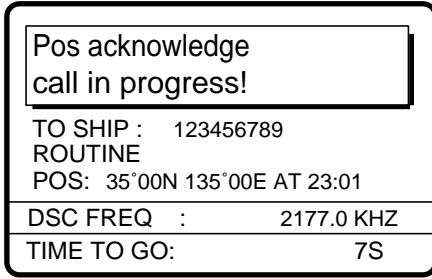

5. The DSC standby screen automatically appears after the call is sent.

## 4.9 PSTN Call

The PSTN call allows the making and receiving of telephone calls over public switched telephone networks.

### 4.9.1 Sending PSTN call, receiving acknowledge back (ACK BQ)

1. Press the [CALL] key followed by the [ENT] key to open the CALL TYPE menu.

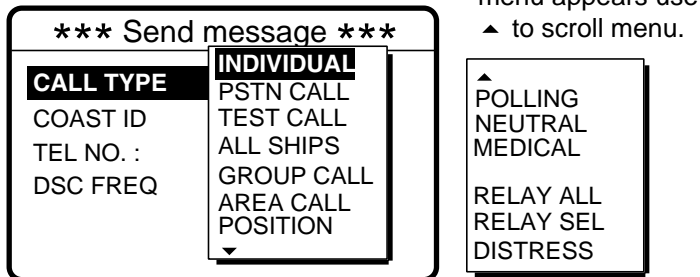

2. Select PSTN CALL and press the [ENT] key.
3. Press the [ENT] key to open the COAST ID menu.

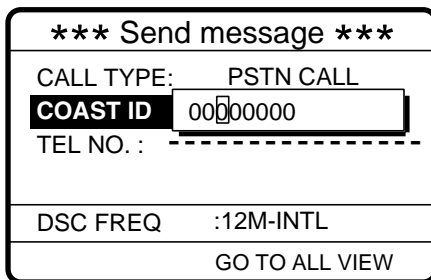

#### How to input coast ID automatically

If you have registered some coast IDs (Chapter 6), you can insert them into your message as follows:

1. Press the [FILE] key after completing step 2 in the above procedure. The following display appears.

PSTN ID file	
300. FURUNO	▶
500. MARINE	▶
777. ELECTRIC	▶
▲ UP	▼ DOWN

**Note:** You can print the PSTN ID file list by pressing the [8/PRINT] key.

2. Select file which contains ID you want to use (press ▶ to show ID number).
3. Press the [ENT] key to insert ID number in message.
4. Key in ID of coast station (nine digits) to where to send the call and press the [ENT] key.

- Press the [ENT] key to open the TEL NO. menu.

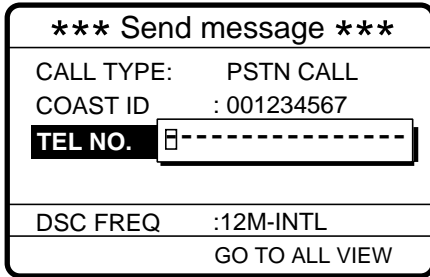

### How to input telephone no. automatically

If you have registered some coast IDs (Chapter 6), you can insert them into your message as follows:

- Press the [FILE] key after completing step 4 in the above procedure. The following display appears.

Telephone no. file	
300. FURUNO	▶
500. MARINE	▶
777. ELECTRIC	▶
▲ UP	▼ DOWN

**Note:** You can print the Telephone no. file list by pressing the [8/PRINT] key.

- Select file which contains no. you want to use (press ▶ to show ID number).
- Press the [ENT] key to insert no. in message.

- Enter telephone no. (16 digits max.) and press the [ENT] key.
- Press the [ENT] key to open the DSC FREQ menu.

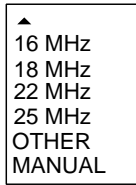
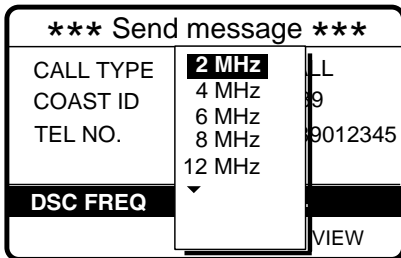

Use ▼ to scroll menu.

OTHER: Special, private channel  
MANUAL: Manual tuning of radiotelephone

- Select DSC band and press the [ENT] key. Select DSC frequency and press the [ENT] key. The display changes as below.

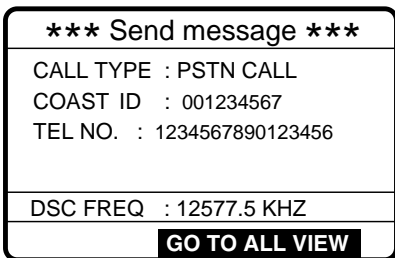

- Press the [CALL] key to send the PSTN call (transmission time: about 7 sec.). The display shows the following message.

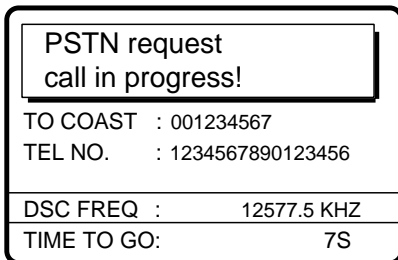

- One of the following three displays appears. ("No response. Try calling again." appears if there is no response from the receiving station - the timer counts down to zero.)

Waiting for acknowledgement.	
FROM COAST :	001234567
TEL NO. :	1234567890123456
DSC FREQ :	12577.5 KHZ
TIME TO GO:	25S

Unable acknowledge call received.	
BUSY	
FROM COAST :	001234567
TEL NO. :	1234567890123456
<b>STOP ALARM</b>	

No response! Try calling again?	
FROM COAST :	001234567
TEL NO. :	1234567890123456
DSC FREQ :	12577.5 KHZ
<b>RE-SEND</b>	

11. Do one of the following depending on the message shown at step 10.

**Waiting for acknowledgement**

- 1) If the PSTN call is accepted, the PSTN connection call is sent (transmission time: about 7 sec.), showing the display below.

PSTN connection call in progress!	
TO COAST :	001234567
TEL NO. :	1234567890123456
TELEPHONE	CH 12001
DSC FREQ :	12230.0 KHZ
TIME TO GO:	7S

- 2) After the call is sent (timer counts down to zero) one of the following message appears.

Waiting for acknowledgement.	
FROM COAST :	001234567
TEL NO. :	1234567890123456
TELEPHONE	CH 12001
DSC FREQ :	12230.0 KHZ
TIME TO GO:	25S

Waiting for acknowledgement

PSTN connection call in progress!	
TO COAST :	001234567
TEL NO. :	1234567890123456
TELEPHONE	CH 16001
DSC FREQ :	16360.0 KHZ
TIME TO GO:	8S

— New channel

Request for new Tx assignment

- 3) One of the follow displays appears.

PSTN call connected.	
TO COAST :	001234567
TEL NO. :	1234567890123456
TELEPHONE	CH 12001
DSC FREQ :	12230.0 KHZ

PSTN call connected

Waiting for acknowledgement.	
FROM COAST :	001234567
TEL NO. :	1234567890123456
TELEPHONE	CH 12001
DSC FREQ :	12230.0 KHZ
TIME TO GO:	25S

Waiting for acknowledgement

PSTN end of call in progress!	
TO COAST :	001234567
TEL NO. :	1234567890123456
DSC FREQ :	12230.0 KHZ
TIME TO GO:	8S

PSTN end of call

- 4) Follow the instructions below depending on the message shown in 3) above.

**PSTN call connected:** Your phone rings; pick up the handset and communicate with called party.

**Waiting for acknowledgement:** If the call is acknowledged the message “PSTN call connected.” appears. Follow “PSTN call connected” above.

**PSTN end of call in progress:** This means channel could not be used. After the timer counts down to zero repeat this procedure to re-send the call.

### **Unable acknowledge**

- 1) The audio alarm sounds; press the [CANCEL] or [ENT] key to silence the alarm. The display shown in the figure below appears.

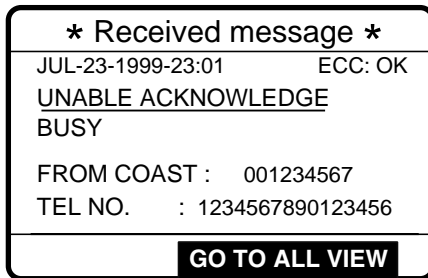

- 2) Press the [CANCEL] key to return to the DSC standby screen.

### **No response! Try calling again?**

**Re-send call:** Press the [ENT] key followed by the [CALL] key.

**Cancel call:** Press the [CANCEL] key to return to the DSC standby screen.

## 4.9.2 Sending PSTN call, receiving acknowledge back (QUEUE indication), ring back

1. Press the [CALL] key followed by the [ENT] key to open the CALL TYPE menu.

```

*** Send message ***
CALL TYPE  INDIVIDUAL
COAST ID   PSTN CALL
TEL NO. :  TEST CALL
DSC FREQ   ALL SHIPS
           GROUP CALL
           AREA CALL
           POSITION
  
```

If this part of the menu appears use ▲ to scroll menu.

```

▲
POLLING
NEUTRAL
MEDICAL

RELAY ALL
RELAY SEL
DISTRESS
  
```

2. Select PSTN CALL and press the [ENT] key.
3. Press the [ENT] key to open the COAST ID menu.

```

*** Send message ***
CALL TYPE:  PSTN CALL
COAST ID   00000000
TEL NO. :  -----
DSC FREQ   :12M-INTL
           GO TO ALL VIEW
  
```

### How to input coast ID automatically

If you have registered some coast IDs (Chapter 6), you can insert them into your message as follows:

1. Press the [FILE] key after completing step 2 in the above procedure. The following display appears.

PSTN ID file	
300. FURUNO	▶
500. MARINE	▶
777. ELECTRIC	▶
▲ UP	▼ DOWN

**Note:** You can print the PSTN ID file list by pressing the [8/PRINT] key.

2. Select file which contains ID you want to use (press ▶ to show ID number).
  3. Press the [ENT] key to insert ID number in message.
4. Key in ID of coast station (nine digits) to where to send the call and press the [ENT] key.
  5. Press the [ENT] key to open the TEL NO. menu.

```

*** Send message ***
CALL TYPE:  PSTN CALL
COAST ID   : 001234567
TEL NO.   E-----
DSC FREQ   :12M-INTL
           GO TO ALL VIEW
  
```

### How to input telephone no. automatically

If you have registered some coast IDs (Chapter 6), you can insert them into your message as follows:

1. Press the [FILE] key after completing step 4 in the above procedure. The following display appears.

Telephone no. file	
300. FURUNO	▶
500. MARINE	▶
777. ELECTRIC	▶
▲ UP	▼ DOWN

**Note:** You can print the Telephone no. file list by pressing the [8/PRINT] key.

2. Select file which contains no. you want to use (press ▶ to show ID number).
  3. Press the [ENT] key to insert no. in message.
6. Enter telephone no. (16 digits max.) and press the [ENT] key.

7. Press the [ENT] key to open the DSC FREQ menu.

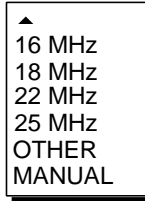
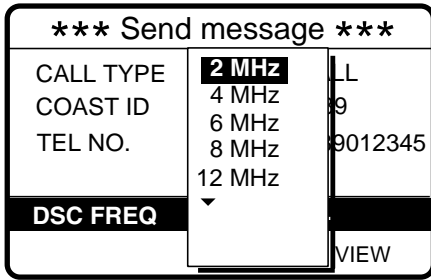

Use ▼ to scroll menu.

OTHER: Special, private channel  
 MANUAL: Manual tuning of radiotelephone

8. Select DSC band and press the [ENT] key. Select DSC frequency and press the [ENT] key. The display changes as below.



9. Press the [CALL] key to send the PSTN call (transmission time: about 7 sec.). The display shows the following message.

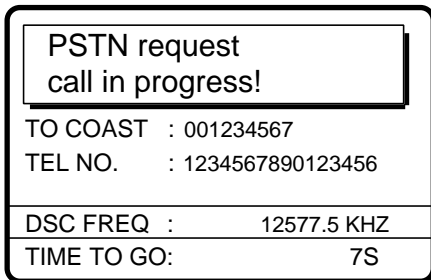

10. After the call is sent one of the following messages appears.

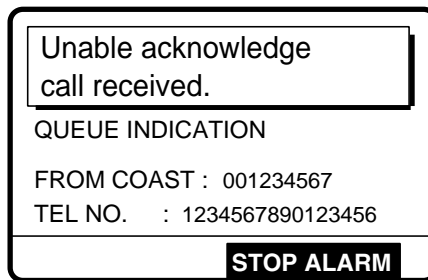
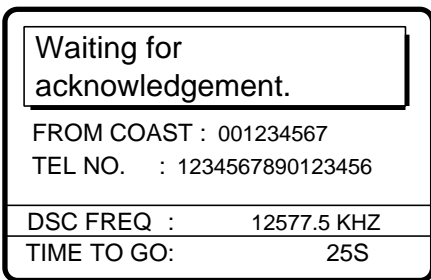



11. Do one of the following depending on the message shown at step 10.

**Waiting for acknowledge**

1) After the timer counts down to zero the following message appears.

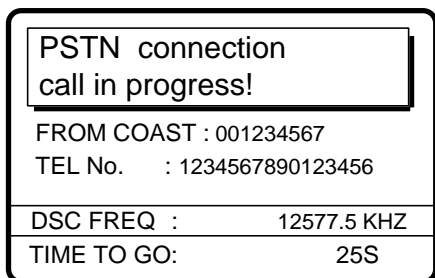

2) After the connection call is sent the following message appears.

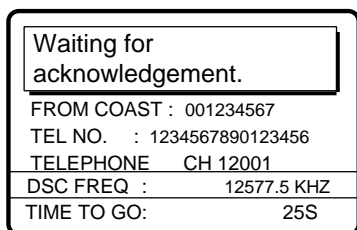

Waiting for acknowledgement

3) After the timer counts down to zero one of the following messages appears.

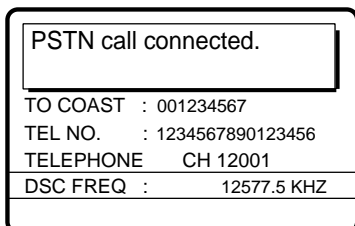

PSTN call connected

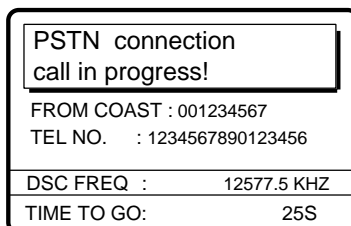

PSTN connection call in progress

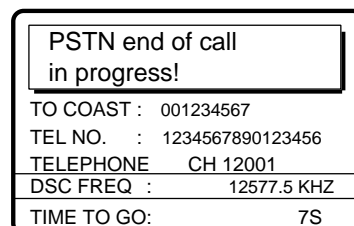

PSTN end of call

**PSTN call connected:** Your phone rings; pick up the handset and communication with receiving station.

**PSTN connection call in progress!:** This means coast station has switched DSC frequency. (If the channel cannot be used the message “PSTN end of call in progress!” appears. In this case, start this procedure again.) If the channel assigned is OK the message “Waiting for acknowledgment.” appears.

**PSTN end of call in progress!:** The channel could not be used. Press the [CANCEL] key to return to the DSC standby screen. Repeat this procedure to send the call again.

## Unable to acknowledge call received

- 1) The alarm sounds; press the [CANCEL] or [ENT] key to silence the alarm. The display changes as below, waiting for the ring back call.

Waiting for ring-back call.	
FROM COAST :	001234567
TEL NO. :	1234567890123456
DSC FREQ :	12577.5 KHZ
TIME TO GO:	15M00S

- 2) One of the following displays appears. (For “No response. Try calling again?”, press the [ENT] key followed by the [CALL] key to re-send the call, or press the [CANCEL] key to cancel the call and return to the DSC standby screen.)

Able acknowledge call in progress!	
TO COAST :	001234567
TEL NO. :	1234567890123456
TELEPHONE	CH121001
DSC FREQ :	12577.5 KHZ
TIME TO GO:	8S

No response! Try calling again?	
FROM COAST :	001234567
TEL NO. :	1234567890123456
DSC FREQ :	12577.5 KHZ
<b>RE-SEND</b>	

- 3) After the acknowledge able call is sent one of the displays shown below appears. For “Pick up the handset or press the CALL key!”, pick up the handset or press the [CALL] key within one minute. (If the handset is not picked up or the [CALL] key is not pressed within one minute the message “PSTN call canceled. Try calling again?” appears. In this case, press the [ENT] key to re-send the call.) For “No response! Try calling again?” you may re-send the call by pressing the [ENT] key followed by the [CALL] key, or cancel the call by pressing the [CANCEL] key.

Pick up the handset or press CALL key!	
FROM COAST :	001234567
TEL NO. :	1234567890123456
TELEPHONE	CH 12001
DSC FREQ :	12577.5 KHZ
TIME TO GO:	60S

No response! Try calling again?	
FROM COAST :	001234567
TEL NO. :	1234567890123456
DSC FREQ :	12577.5 KHZ
<b>RE-SEND</b>	

- 4) The message “PSTN call in progress!” appears after you press the [CALL] key. Follow from 2) above.

### 4.9.3 Receiving PSTN call, sending acknowledge back (ACK BQ)

1. The following display appears when a PSTN call is received.

Able acknowledge call in progress!	
TO COAST :	001234567
TEL NO. :	1234567890123456
TELEPHONE	CH 12001
DSC FREQ :	12577.5 KHZ
TIME TO GO:	8S

2. The timer counts down to zero and the following display appears.

Pick up the handset or press CALL key.	
FROM COAST :	001234567
TEL NO. :	1234567890123456
TELEPHONE	CH 12001
DSC FREQ :	12577.5 KHZ
TIME TO GO:	60S

PSTN call canceled. Try calling again.	
FROM COAST :	001234567
TEL NO. :	1234567890123456
TELEPHONE	CH 12001
DSC FREQ :	12577.5 KHZ
<b>RE-SEND</b>	

3. Pick up the handset or press the [CALL] key within one minute. (If this not done within one minute the call is canceled, displaying the message "PSTN call canceled. Try calling again.". Press the [ENT] key to call followed by the [CALL] key to re-send the call.)

PSTN connection call in progress!	
TO COAST :	001234567
TEL NO. :	1234567890123456
TELEPHONE	CH 12001
DSC FREQ :	12577.5 KHZ
TIME TO GO:	7S

4. When the timer counts down to zero the following message appears.

Waiting for acknowledgement.	
FROM COAST :	001234567
TEL NO. :	1234567890123456
TELEPHONE	CH 12001
DSC FREQ :	12577.5 KHZ
TIME TO GO:	25S

5. One of the following messages appears.

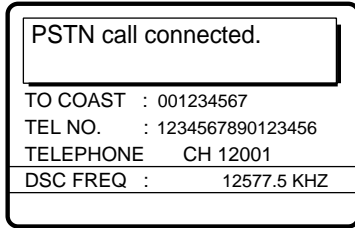

PSTN call connected

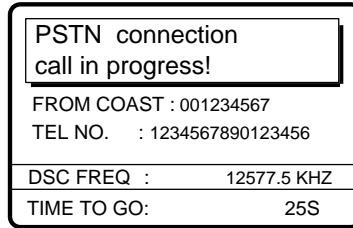

PSTN connection call in progress

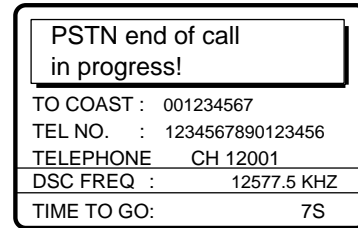

PSTN end of call

6. Do one of the following depending on the message shown at step 5.

**PSTN call connected:** Your phone rings; pick up the handset and communication with receiving station.

**PSTN connection call in progress!:** This means coast station has switched DSC frequency. (If the channel cannot be used the message “PSTN end of call in progress!” appears. In this case, start this procedure again.) If the channel assigned is OK the message “Waiting for acknowledgment.” appears.

**PSTN end of call in progress!:** The channel could not be used. Press the [CANCEL] key to return to the DSC standby screen. Repeat this procedure to send the call again.

#### 4.9.4 PSTN call disconnection, receiving charge information (ship disconnects line)

1. After hanging up the handset or pressing the [CANCEL] key to complete your call the display shows the following message.

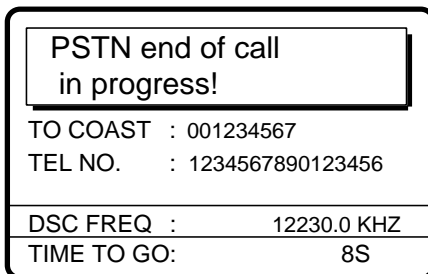

2. After the call is sent one of the following messages appears. (For time out the message “PSTN end of call in progress!” appears. After the timer counts down to zero “Waiting for charge information.” appears.)

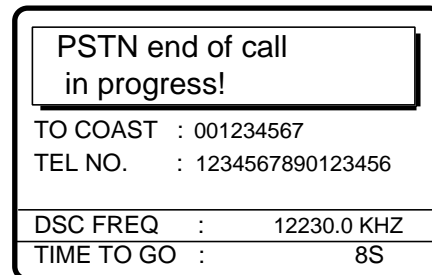
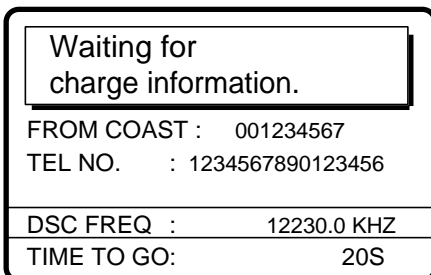

3. When the timer counts down to zero one of the following displays appear.

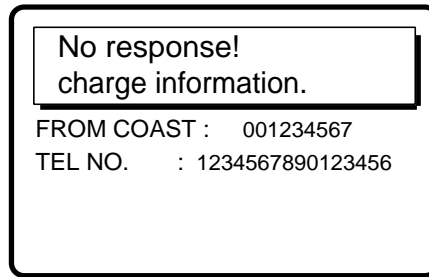
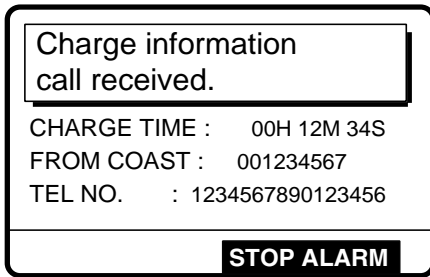

4. For **“No response! charge information.”**, the equipment reverts to step 2 in this procedure to await charge information. For **“Charge information call received.”** the audio alarm sounds; press the [CANCEL] key or [ENT] key to silence the audio alarm. The display shown below appears.



#### 4.9.5 PSTN call disconnection, receiving charge information (coast station disconnects line)

1. The PSTN line is disconnected by the coast station when it finds no evidence of communications or the land subscriber hangs up. The coast station then sends charge information as below.



2. For no charge information the display looks as below.



# 5. LOG FILE

The log file stores routine received messages (messages other than Distress), received distress messages and transmitted messages, each in its own separate log.

## 5.1 Log File Description

Three memory banks are provided for storage of messages: received ordinary log, received distress log and transmitted log. Each memory bank stores 50 messages, on a first-in, first-out basis. This means that a latest message is saved as log no.1 and the log no. of all previous messages in that memory bank increments by one. When the storage capacity is exceeded the oldest message is deleted to make room for the latest. An asterisk (\*) marks unread or unacknowledged Rx messages, unacknowledged Tx messages and unread distress messages. Received distress messages are automatically deleted 48 hours after being read.

## 5.2 Opening a Log File

### 5.2.1 Distress log

1. Press the [0/LOG] key to open the Log file menu.

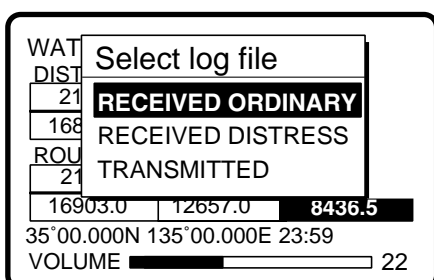

2. Select RECEIVED DISTRESS and press the [ENT] key. Use ▲ or ▼ to scroll the log as desired. To print all received distress messages, press the [8/PRINT] key.

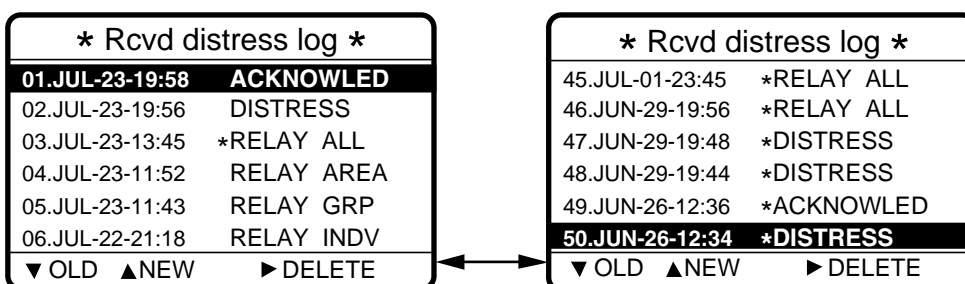

Scroll with  
▲ or ▼.

3. To view a file, select it and press the [ENT] key. To print file, display it and press the [8/PRINT] key. To return to the distress log, press the [CANCEL] key.

* Rcvd distress log *	
45.JUL-01-23:45	*RELAY ALL
46.JUN-29-19:56	*RELAY ALL
47.JUN-29-19:48	*DISTRESS
48.JUN-29-19:44	*DISTRESS
49.JUN-26-12:36	*ACKNOWLED
<b>50.JUN-26-12:34</b>	<b>*DISTRESS</b>
▼ OLD ▲ NEW	▶ DELETE

Select file,  
press [ENT]  
to view.

* Received message *	
JUN-26-1999-12:34:56	ECC: OK
<u>DISTRESS CALL</u>	
SHIP IN DIST : 987654321	
NATURE : UNDESIGNATED	
POS : 12°34N 123°45E AT 12:34	
TELEPHONE	2182.0 KHZ
ANSWER ◀	▶ <b>ALL VIEW</b>

4. To delete a file, select it, press ▶ to select DELETE, and press the [ENT] key. The log files are renumbered to reflect the deletion.

**Note:** Unread files cannot be deleted.

* Rcvd distress log *	
45.JUL-01-23:45	*RELAY ALL
46.JUN-29-19:56	*RELAY ALL
47.JUN-29-19:48	*DISTRESS
48.JUN-29-19:44	*DISTRESS
49.JUN-26-12:36	*ACKNOWLED
<b>50.JUN-26-12:34</b>	<b>*DISTRESS</b>
▼ OLD ▲ NEW	▶ <b>DELETE</b>

Select file to delete,  
press ▶ to select  
DELETE, press  
[ENT] to delete.

* Rcvd distress log *	
44.JUL-01-12:34	*RELAY ALL
45.JUL-01-23:45	*RELAY ALL
46.JUN-29-19:56	*RELAY ALL
47.JUN-29-19:48	*DISTRESS
48.JUN-29-19:44	*DISTRESS
49.JUN-26-12:36	*ACKNOWLED
▼ OLD ▲ NEW	▶ DELETE



## 5.2.2 Ordinary log

1. Press the [0/LOG] key to open the Log file menu.

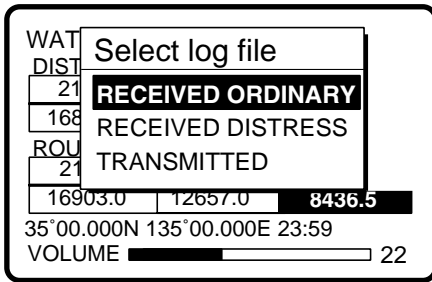

2. Press the [ENT] key to open the received ordinary log. To print all ordinary received messages, press the [8/PRINT] key.

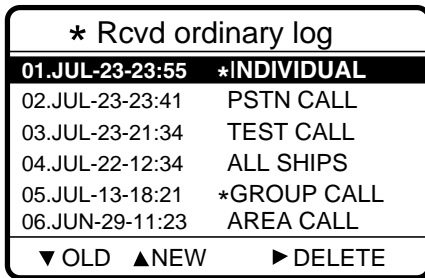

3. Use <math>\blacktriangledown</math> or <math>\blacktriangle</math> to scroll the log.
4. To view the contents of a file, select it and press the [ENT] key. To print a file, display it and press the [8/PRINT] key. To return to the received ordinary log, press the [CANCEL] key.

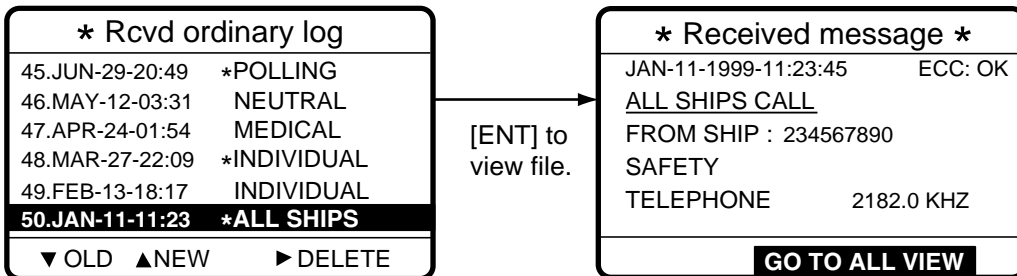

5. To delete a file, select it, press <math>\blacktriangleright</math> to select DELETE, and press the [ENT] key. The log files are renumbered to reflect the deletion.

**Note:** Unread files cannot be deleted.

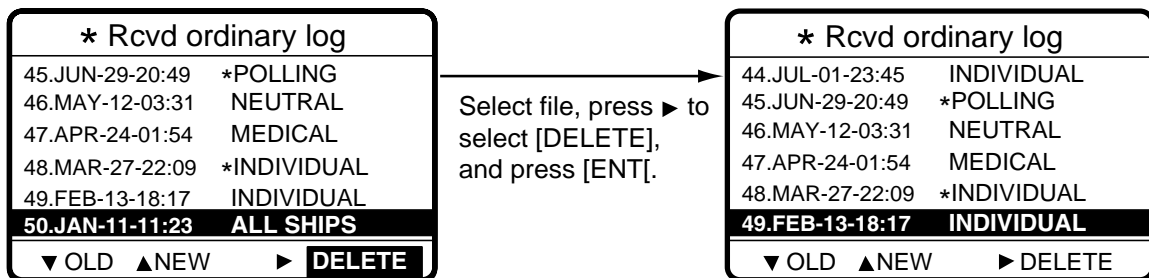

### 5.2.3 Transmitted log

1. Press the [LOG] key to open the Log file menu.

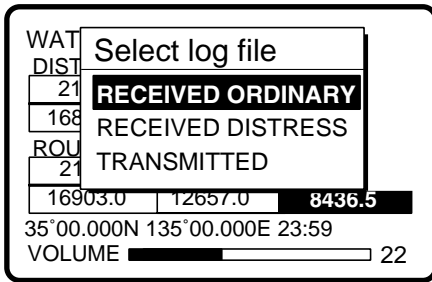

2. Select TRANSMITTED and press the [ENT] key. To print all transmitted messages, press the [8/PRINT] key.

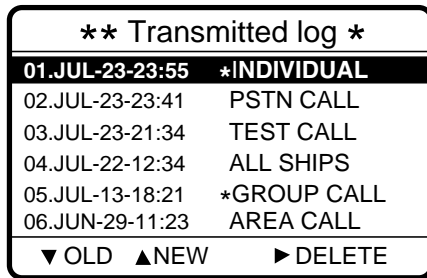

3. Use < or > to scroll the log.
4. To view the contents of a file select it and press the [ENT] key. To print a file, display it and press the [8/PRINT] key.

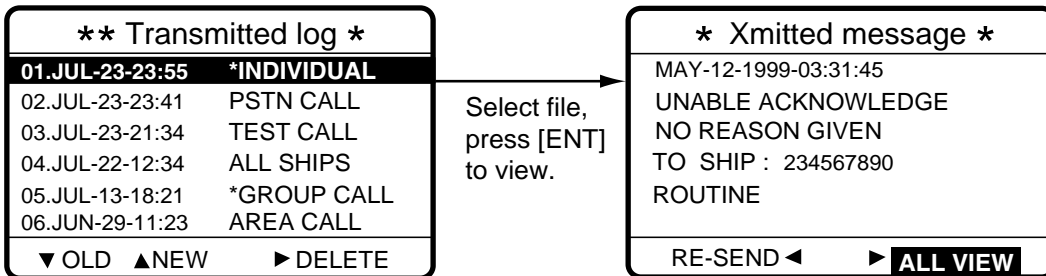

5. To delete a file, select it, press > to select DELETE, and press the [ENT] key. The log files are renumbered to reflect the deletion.

**Note:** Unread files cannot be deleted.

6. To re-send a file do the following:
  - a) Do steps 1-4 above to select file to re-send.
  - b) Press < to select RE-SEND.
  - c) Press the [ENT] key.
  - d) Press the [CALL] key.

# 6. PREPARING SEND MESSAGES

In Chapter 4 you learned how to prepare and send individual, group, geographical area and PSTN calls. In this chapter you will learn how to prepare and store them (including test calls) for future transmission. 150 such files can be stored.

## 6.1 Preparing Individual Call Messages

1. Press the [#/SETUP] key to open the Setup menu.
2. Select MESSAGE and press the [ENT] key.
3. Press the [ENT] key to open the CALL TYPE menu.

* Message file entry	
<b>CALL TYPE</b>	<b>INDIVIDUAL</b>
STATION ID	PSTN CALL
COM. TYPE	GROUP CALL
COM. FREQ	AREA CALL
DSC FREQ	TEST CALL
▼	

4. Use ▲ or ▼ to select INDIVIDUAL and press the [ENT] key.
5. Press the [ENT] key to open the STATION ID entry window.

* Message file entry	
CALL TYPE	: INDIVIDUAL
<b>STATION ID</b>	□-----
COM. TYPE	: TELEPHONE
COM. FREQ	: NO INFO
DSC FREQ	: 2M-INTL
▼	

### How to input station ID automatically

If you have previously registered some station IDs, you can insert them into your message as follows:

1. Press the [FILE] key after completing step 4 in the above procedure. The following display appears.

Select ID file
COAST STATION
SHIP STATION

**Note:** You can print the Select ID file list by pressing the [8/PRINT] key.

2. Select COAST STATION or SHIP STATION and press the [ENT] key.
  3. Select file which contains ID you want to use (press ▶ to show ID number).
  4. Press the [ENT] key to insert ID number in message.
6. Key in ID of coast station or ship station which is to receive the call and press the [ENT] key.

7. Press the [ENT] key to open the COM. TYPE window.

* Message file entry	
CALL TYPE:	INDIVIDUAL
STATION ID :	001001507
<b>COM. TYPE</b>	<b>TELEPHONE</b>
COM. FREQ	NBDP-ARQ
DSC FREQ :	NBDP-FEC
▼	

8. Select communication type desired and press the [ENT] key.

9. Press the [ENT] key to open the COM. FREQ window.

* Message file entry	
CALL TYPE:	INDIVIDUAL
STATION ID :	122156780
COM. TYPE :	<b>NO INFO</b>
<b>COM. FREQ</b>	FREQUENCY
DSC FREQ :	CHANNEL
	POSITION*
▼	

\* POSITION appears when coast station ID is entered in the field STATION ID.

10. Choose appropriate item and press the [ENT] key.

To coast station: NO INFO or POSITION.

To ship station: FREQUENCY or CHANNEL. Enter appropriate frequency or channel, referring to page 4-6.

11. Press the [ENT] key to open the DSC FREQ menu.

* Message file entry	
CALL TYPE	INDIVIDUAL
STATION ID	122156780
COM. TYPE	FREQUENCY
COM. FREQ	CHANNEL
<b>DSC FREQ</b>	<b>2 MHZ</b>
	4 MHZ
	6 MHZ
	8 MHZ
	12 MHZ
	▼
▼	

▲
16 MHZ
18 MHZ
22 MHZ
25 MHZ
OTHER
MANUAL

Use ▼ to scroll menu.

**OTHER:** Special, private channels.  
**MANUAL:** For selection of frequency at radiotelephone when there is "remote control error."

12. Select appropriate DSC band and press the [ENT] key. Select DSC frequency and press the [ENT] key.

13. Enter file name and file number as shown on the next page.

## How to Enter File Name and Number

1. Press the [ENT] key to open the file name entry window.

2. Use the numeric keys and cursor pad to enter file name (max. 16 characters) and press the [ENT] key. For example, enter FURUNO as the file name.

### How to assign file name

[1\_] key : 1→\_→1  
 [2ABC] : 2→A→B→C→2  
 [3DEF] : 3→D→E→F→3  
 [4GHI] : 4→G→H→I→4  
 [5JKL] : 5→J→K→L→5  
 [6MNO] : 6→M→N→O→6  
 [7PQRS] : 7→P→Q→R→S→7  
 [8TUV] : 8→T→U→V→8  
 [9WXYZ] : 9→W→X→Y→Z→9  
 [0\_] : 0→\_→0

1. Press ◀ or ▶ to select location.
2. Press appropriate key.

### How to enter "FURUNO" as file name

1. Press the [3] key to display F.
2. Press ▶.
3. Press the [8] key to select U.
4. Press ▶.
5. Press the [7] key to select R.
6. Press ▶.
7. Press the [8] key to select U.
8. Press ▶.
9. Press the [6] key to select N.
10. Press ▶.

3. Press the [ENT] key to open the file number entry window. Key in file number in three digits with the numeric keys, and press the [ENT] key. For example, press [0] [0] [1] [ENT] to enter file number 001.

**Note:** The available file number is 001-799 and 900-999. Do not use "8" as the first digit of a file number.

4. Press the [ENT] key. The display shows the name and file number entered.

If the file name or number exists the message "Duplicate name (number) ! Overwrite OK?" appears. Press [ENT] to write over the name, or press the [CANCEL] key to escape.

5. Press the [ENT] key to continue.

## 6.2 Preparing Group Call Messages

1. Press the [#/SETUP] key to open the Setup menu.
2. Select MESSAGE and press the [ENT] key.
3. Press the [ENT] key to open the CALL TYPE menu.

* Message file entry	
<b>CALL TYPE</b>	<b>INDIVIDUAL</b>
STATION ID	PSTN CALL
COM. TYPE	GROUP CALL
COM. FREQ	AREA CALL
DSC FREQ	TEST CALL
▼	

4. Use ▲ or ▼ to select GROUP CALL and press the [ENT] key.
5. Press the [ENT] key to open the GROUP ID entry window.

* Message file entry	
CALL TYPE:	GROUP CALL
<b>GROUP ID</b>	00000000
COM. TYPE	: TELEPHONE
COM. FREQ	: NO INFO
DSC FREQ	: 2M-INTL
▼	

### How to input group ID automatically

If you have previously registered some group IDs, you can insert them into your message as follows:

1. Press the [FILE] key after completing step 4 in the above procedure. The following display appears.

Group ID file	
004. FURUNO	▶
500. MARINE	▶
777. ELECTRIC	▶
▲ UP ▼ DOWN	

**Note:** You can print the Group ID file list by pressing the [8/PRINT] key.

2. Select file which contains ID you want to use (press ▶ to show ID number).
3. Press the [ENT] key to insert ID number in message.
6. Key in ID of group which is to receive the call and press the [ENT] key.
7. Press the [ENT] key to open the COM. TYPE menu.

* Message file entry	
CALL TYPE:	GROUP CALL
GROUP ID	: 012345678
<b>COM. TYPE</b>	<b>TELEPHONE</b>
COM. FREQ	: NBDP-FEC
DSC FREQ	: 2M-INTL
▼	

8. Select appropriate communications type and press the [ENT] key.
9. Press the [ENT] key to open the COM. FREQ menu.

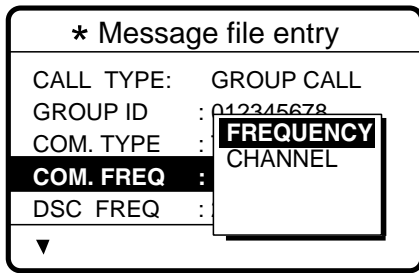

10. Choose appropriate item and press the [ENT] key. (See page 4-6 for details for how to enter frequency and channel.)
11. Press the [ENT] key to open the DSC FREQ menu.

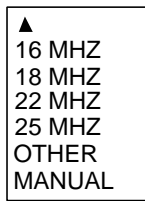
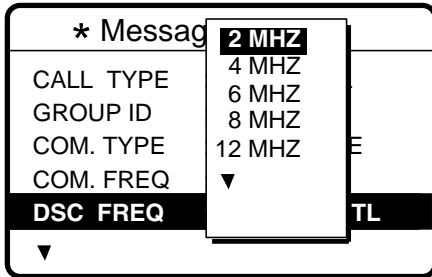

Use ▼ to scroll menu.

**OTHER:** Special, private channels.  
**MANUAL:** For selection of frequency at radiotelephone when there is "remote control error."

12. Select appropriate DSC band and press the [ENT] key. Select appropriate DSC frequency and press the [ENT] key.
13. Follow "How to Enter File Name and Number" on page 6-3 to enter file name and number.

**Note:** Your ship's group ID will be as registered as entered in step 6 of this procedure.

### 6.3 Preparing Geographical Area Call Messages

1. Press the [#]/SETUP] key to open the Setup menu.
2. Select MESSAGE and press the [ENT] key.
3. Press the [ENT] key to open the CALL TYPE menu.

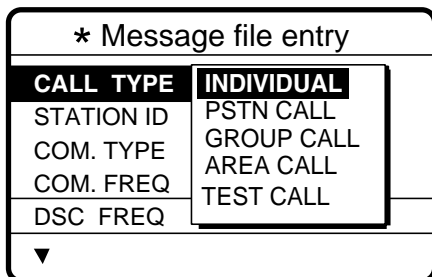

4. Use ▲ or ▼ to select AREA CALL and press the [ENT] key.
5. Press the [ENT] key to open the AREA entry window.

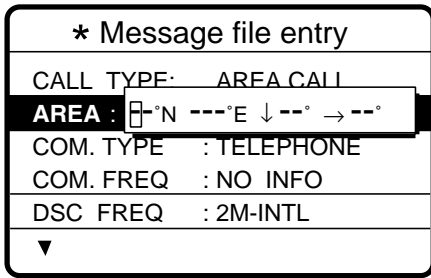

6. Enter latitude, longitude, southerly degrees and easterly degrees of area with the numeric keys and press the [ENT] key. Use ▲ or ▼ to switch from North to South latitude and vice versa and East to West longitude and vice versa.
7. Press the [ENT] key to open the COM. TYPE menu.

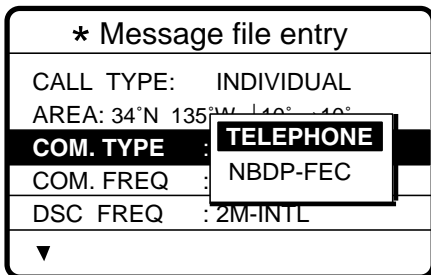

8. Select appropriate item and press the [ENT] key.
9. Press the [ENT] key to open the COM. FREQ menu.

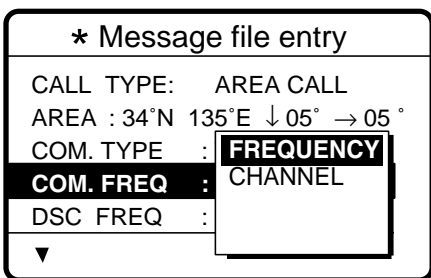

9. Select appropriate item and press the [ENT] key. (See page 4-6 for how to enter channel and frequency.)
10. Press the [ENT] key to open the DSC FREQ menu.

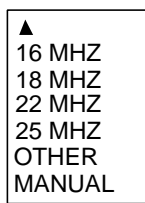
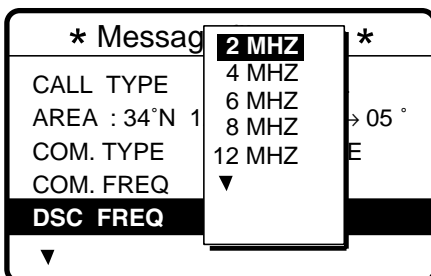

Use ▼ to scroll menu.

**OTHER:** Special, private channels.  
**MANUAL:** For selection of frequency at radiotelephone when there is "remote control error."

11. Select appropriate DSC band and press the [ENT] key. Select DSC frequency and press the [ENT] key.
12. Follow "How to Enter File Name and Number" on page 6-3 to enter file name and number.



## 6.4 Preparing PSTN Call Messages

1. Press the [#/SETUP] key to open the Setup menu.
2. Select MESSAGE and press the [ENT] key.
3. Press the [ENT] key to open the CALL TYPE menu.

* Message file entry	
<b>CALL TYPE</b>	<b>INDIVIDUAL</b>
STATION ID	PSTN CALL
COM. TYPE	GROUP CALL
COM. FREQ	AREA CALL
DSC FREQ	TEST CALL
▼	

4. Select PSTN CALL and press the [ENT] key.
5. Press the [ENT] key to open the COAST ID entry window.

* Message file entry	
CALL TYPE	: PSTN CALL
<b>COAST ID</b>	<b>00000000</b>
TEL NO. :	-----
DSC FREQ	: 2M-INTL
▼	

### How to input coast ID automatically

If you have previously registered some coast IDs, you can insert them into your message as follows:

1. Press the [FILE] key after completing step 4 in the above procedure. The following display appears.

PSTN ID file	
300. FURUNO	▶
500. MARINE	▶
777. ELECTRIC	▶
▲ UP	▼ DOWN

**Note:** You can print the PSTN ID file list by pressing the [8/PRINT] key.

2. Select file which contains ID you want to use (press ▶ to show ID number).
3. Press the [ENT] key to insert ID number in message.
6. Key in ID of coast station (seven digits) to send the call to and press the [ENT] key.
7. Press the [ENT] key to open the TEL. NO. entry window.

* Message file entry	
CALL TYPE:	PSTN CALL
COAST ID	: 001234567
<b>TEL NO. :</b>	<b>□-----</b>
DSC FREQ	: 2M-INTL
▼	

### How to input telephone no. automatically

If you have previously registered some coast IDs, you can insert them into your message as follows:

1. Press the [FILE] key after completing step 6 in the above procedure. The following display appears.

Telephone no. file	
300. FURUNO	▶
500. MARINE	▶
777. ELECTRIC	▶
▲ UP	▼ DOWN

**Note:** You can print the Telephone no. file list by pressing the [8/PRINT] key.

2. Select file which contains no. you want to use (press ▶ to show ID number).
3. Press the [ENT] key to insert no. in message.
8. Key in telephone no. (max. 16 digits) and press the [ENT] key.
9. Press the [ENT] key to open the DSC FREQ menu.

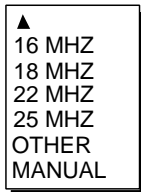
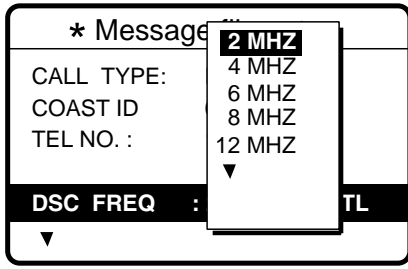

Use ▼ to scroll menu.

**OTHER:** Special, private channels.  
**MANUAL:** For selection of frequency at radiotelephone when there is "remote control error."

10. Select appropriate DSC band and press the [ENT] key. Select DSC frequency and press the [ENT] key.
11. Follow "How to Enter File Name and Number" on page 6-3 to enter file name and number.

## 6.5 Preparing Test Call Messages

3. Press the [#]/SETUP] key to open the Setup menu.
4. Select MESSAGE and press the [ENT] key.
5. Press the [ENT] key to open the CALL TYPE menu.

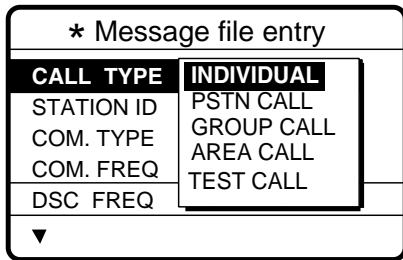

4. Select TEST CALL and press the [ENT] key.
5. Press the [ENT] key to open the COAST ID menu.

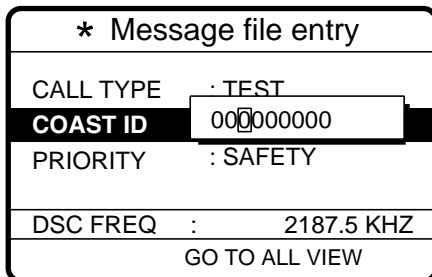

### How to input coast ID automatically

If you have previously registered some coast IDs, you can insert them into your message as follows:

1. Press the [FILE] key after completing step 4 in the above procedure. The following display appears.

Test ID file	
300. FURUNO	▶
500. MARINE	▶
777. ELECTRIC	▶
▲ UP ▼ DOWN	

**Note:** You can print the Test ID file list by pressing the [8]/PRINT] key.

2. Select file which contains ID you want to use (press ▶ to show ID number).
3. Press the [ENT] key to insert ID number in message.

- Press the [ENT] key to open the DSC FREQ menu.

* Message file entry	
CALL TYPE	<b>2187.5</b>
COAST ID	4207.5
PRIORITY	6312.0
	8414.5
	12577.0
	16804.5
<b>DSC FREQ</b>	MANUAL
	CHZ

**MANUAL:** For selection of frequency at radiotelephone when there is "remote control error."

- Select appropriate DSC frequency and press the [ENT] key.
- Follow "How to Enter File Name and Number" on page 6-3 to enter file name and number.

## 6.6 Sending Prepared Messages

- Press the [\*/FILE] key at the DSC standby screen to show the send message file list. Below is an example of the send message file list.

* Send message file *	
<b>001 - FURUNO JAPAN</b>	
002 - FURUNO USA	
003 - FURUNO UK	
004 - FURUNO DENMARK	
005 - FURUNO NORWAY	
006 - FURUNO SPAIN	
007 - FURUNO FRANCE	
▲ UP ▼ DOWN ▶ DELETE	

- Select file with ▲ or ▼ . (You can also select a file by entering its number with the numeric keys and pressing the [ENT] key.)
- Press the [CALL] key to send the file.

**Note:** You can delete a file by selecting it, pressing ▶ followed by the [ENT] key.

## 6.7 Printing List of Send Message Files

You can print a list of send message files as follows:

1. Press the [\* / FILE] key to open the Send message file list.
2. Press the [8 / PRINT] key.
3. Press ◀ to select YES and press the [ENT] key.

```
***** Send message file *****  
001. FURUNO JAPAN      INDIVIDUAL CALL  
002. FURUNO USA       INDIVIDUAL CALL  
003. FURUNO UK        PSTN CALL  
004. FURUNO DENMARK   GROUP CALL  
005. FURUNO NORWAY    INDIVIDUAL CALL  
006. FURUNO SPAIN     ALL SHIPS CALL  
007. FURUNO FRANCE    INDIVIDUAL CALL
```

**Note:** Message not framed in actual printout.

# 7. SETUP MENU

## 7.1 Setup Menu Overview

The Setup menu, consisting of 11 menus, provides for set up of the equipment according to expected usage and user's preferences.

1. At the DSC standby screen, press the [#/SETUP] key to display the Setup menu.

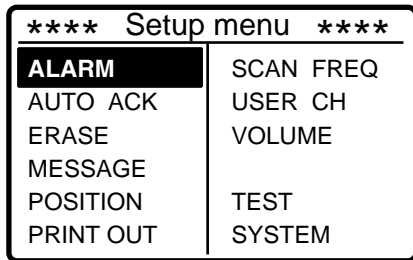

2. Use the Cursor Pad to select a menu and press the [ENT] key. For example, select the Volume menu.

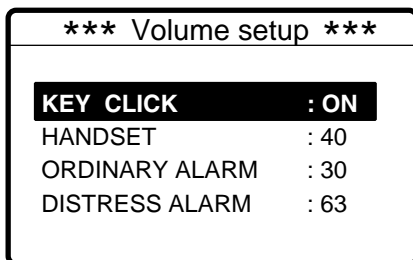

3. Use the Cursor Pad to choose item and press the [ENT] key. For example, select KEY CLICK. A pop-up window showing choices appears.

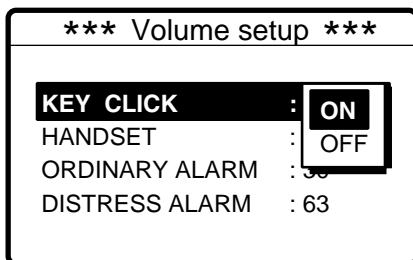

4. Use ▲ or ▼ to choose option desired and press the [ENT] key.
5. Press the [CANCEL] key twice to close the menu and return to the DSC standby screen.

## 7.2 Alarm Menu

The Alarm menu enables/disables internal and external alarms. Note that the Distress/Urgency alarm cannot be disabled. Press the [# / SETUP] key, select ALARM and press the [ENT] key to display the Alarm menu.

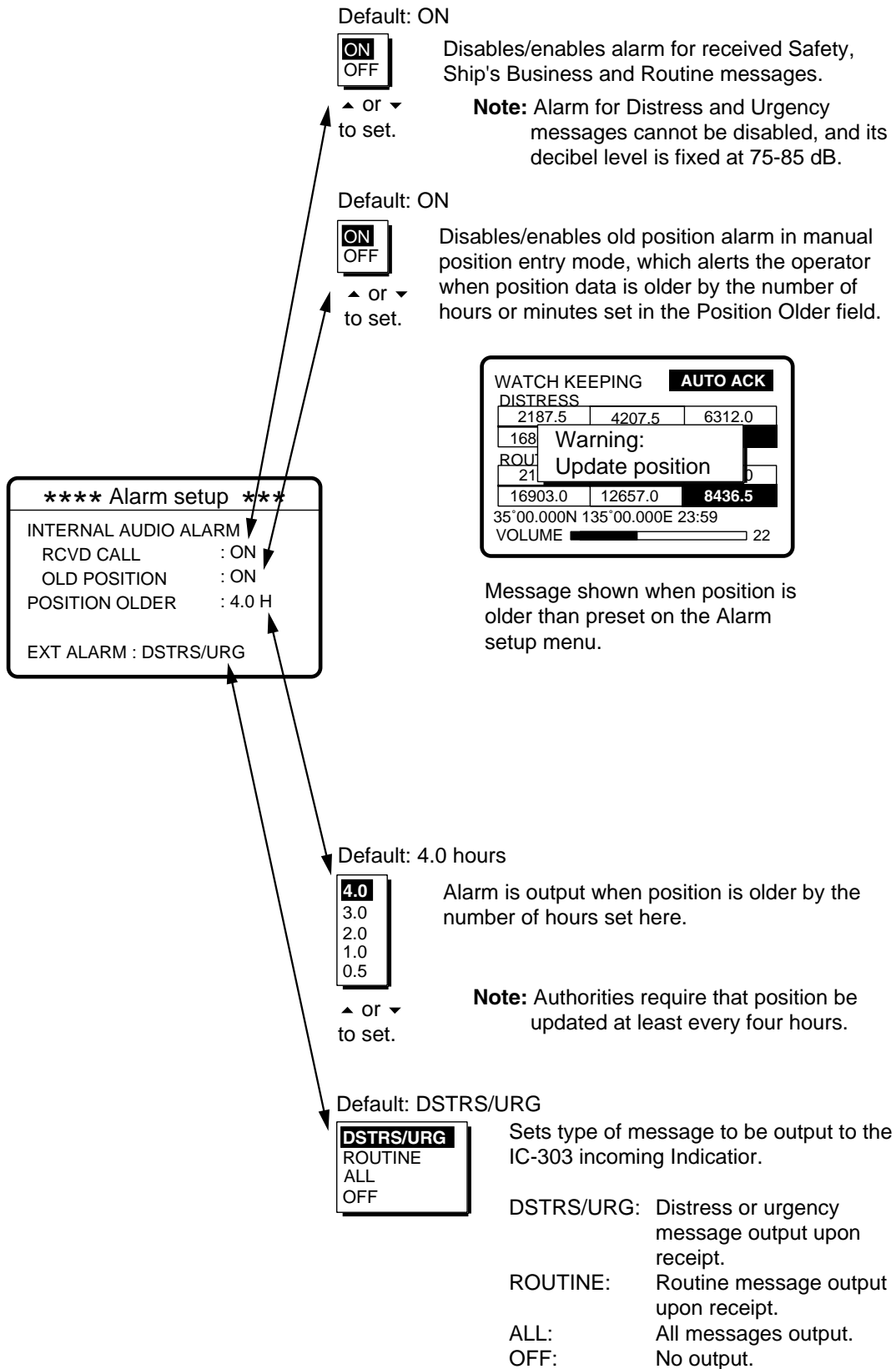

## 7.3 Auto Ack Menu

The Auto Ack menu enables/disables automatic acknowledgement of individual, position and polling calls. Press the [# / SETUP] key, select AUTO ACK and press the [ENT] key to display the Auto Ack setup menu. See the next page for the Auto Ack menu.

<b>Comply type, automatic acknowledge</b>	<b>ABLE</b>	<b>UNABLE</b>
AUTO ACK	Can send acknowledge automatically	Can send UNABLE automatically
MANUAL ACK	Can send acknowledge manually	Can send UNABLE manually

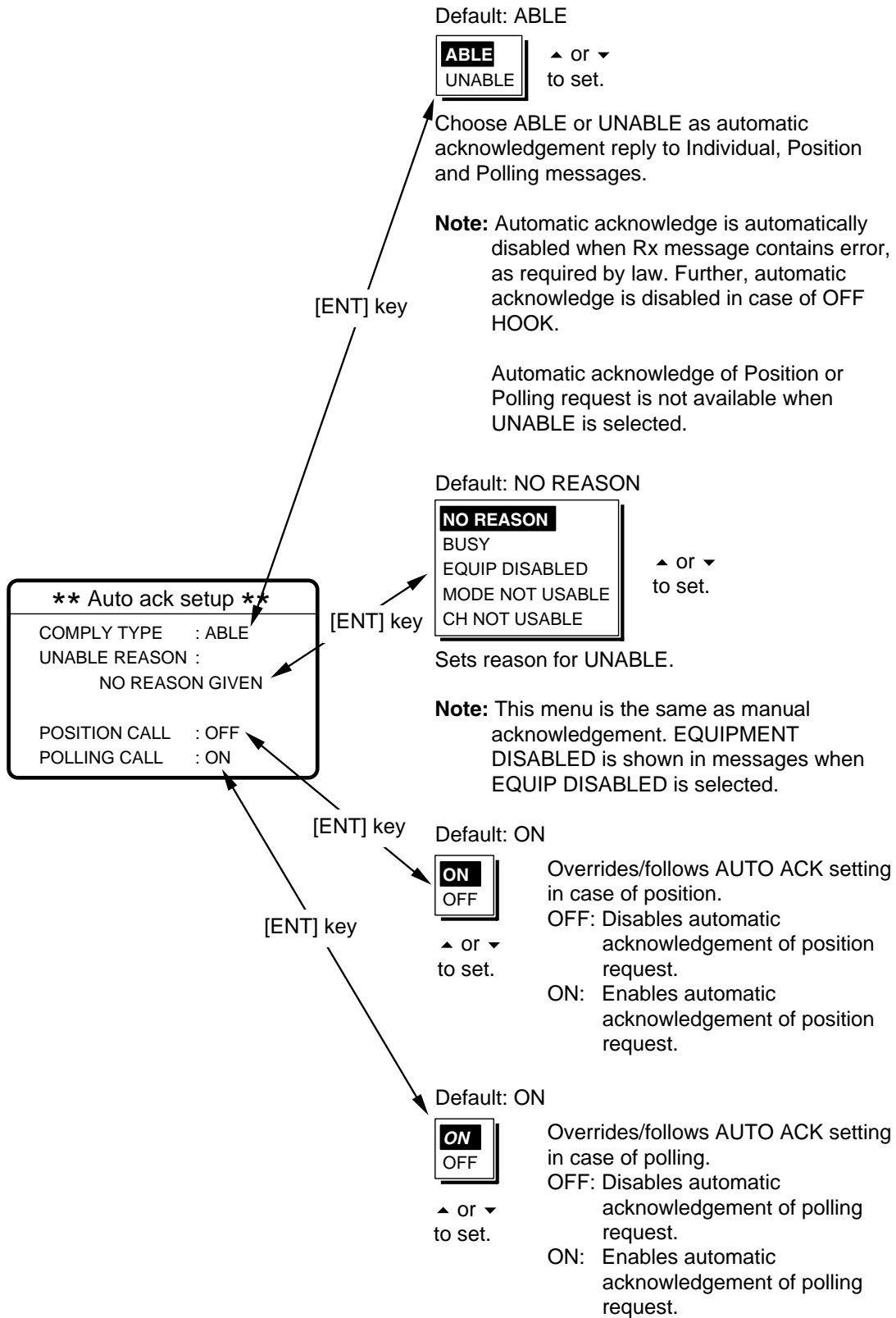



## 7.4 Erase File Menu

The Erase file menu separately erases the entire contents of the received ordinary log, received distress log, transmitted log, send messages and user channels. Press the [# / SETUP] key, select ERASE FILE and press the [ENT] key to display the Erase file menu. Select the item to erase and press the [ENT] key.

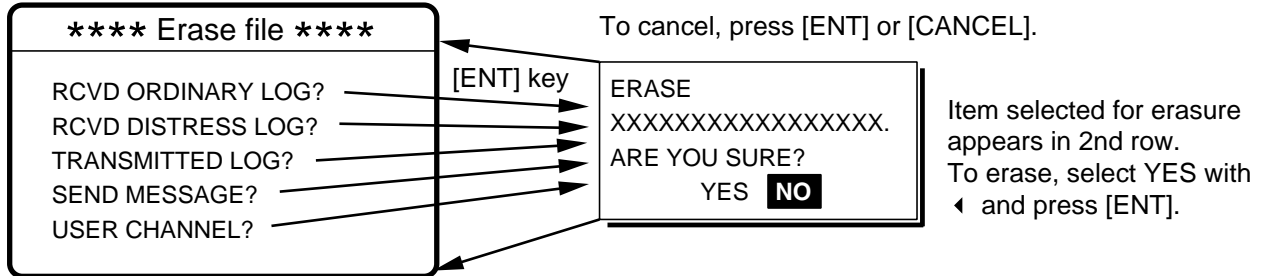

## 7.5 Message Menu

The Message menu prepares and stores messages for later transmission. Press the [# / SETUP] key, select MESSAGE and press the [ENT] key to display the Message menu. For further details see Chapter 6.

## 7.6 Position Menu

Position and time are entered (automatically or manually) on the Position menu. Manually enter position and time when the DSC-60 is not interfaced with EPFS or the EPFS is not working. Press the [# / SETUP] key, select POSITION and press the [ENT] key to display the Position menu. For further details see Paragraph 2.10 “Manual Input of Position and Time” on page 2-10.

## 7.7 Print Out Menu

The Print Out menu enables/disables automatic printing of transmitted and received messages and the results of the daily test. Press the [# / SETUP] key, select PRINT OUT and press the [ENT] key to display the Print Out menu.

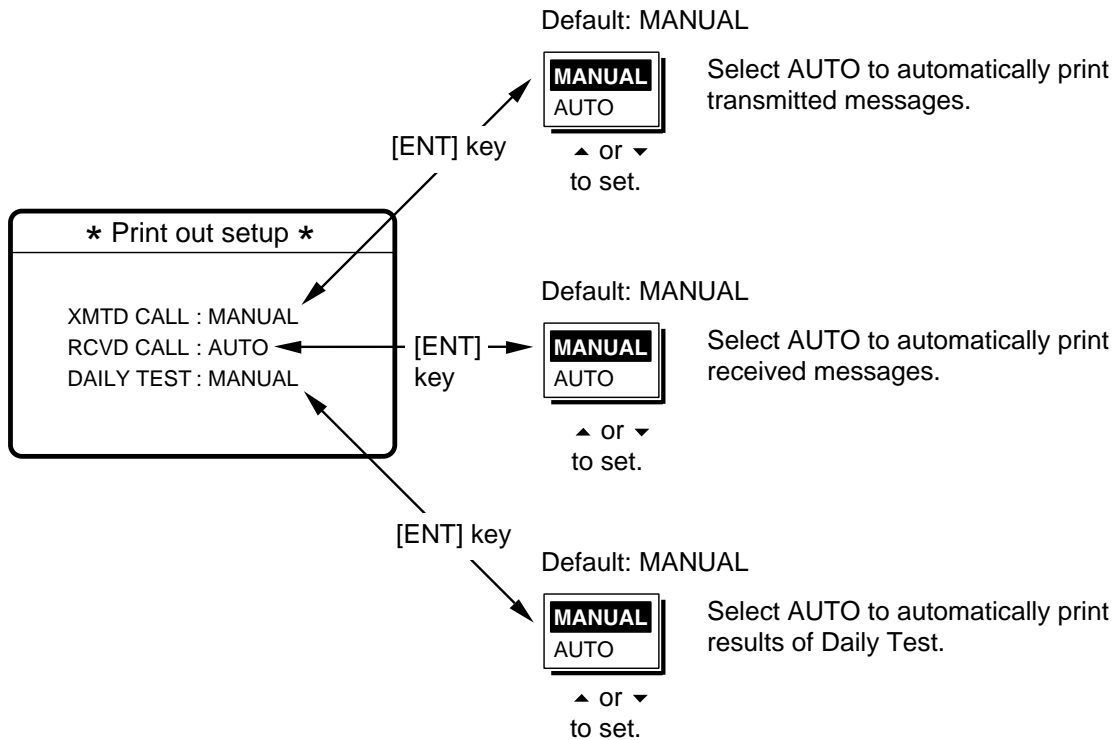

## 7.7.1 Sample printouts

Printing can be done automatically or manually. For manual printing, press the [8/PRINT] key. Note that messages comprised of more than one page (for example, received messages) are printed out in their entirety.

```
* Received message at JAN-08-1999-16:10:12 *
FORMAT          : DISTRESS CALL
SELF-IDENTITY   : 987654321
NATURE OF DISTRESS : UNDESIGNATED DISTRESS
DISTRESS COORDINATES: NO INFORMATION
DISTRESS TELECOMMAND: J3E TELEPHONE
END OF SEQUENCE  : EOS
ERROR-CHECK     : OK

DSC FREQUENCY   TX: 2187.5 kHz
                 RX: 2187.5 kHz
```

Sample Received Message  
Printout (Distress)

```
* Received message at JAN-08-1999-16:10:12 *
FORMAT          : INDIVIDUAL CALL
ADDRESS         : 111660000
CATEGORY       : ROUTINE
SELF-IDENTITY   : 987654321
1st TELECOMMAND : J3E TELEPHONE
2nd TELECOMMAND : NO INFORMATION
WORKING FREQUENCY : NO INFORMATION
END OF SEQUENCE  : ACK. RQ
ERROR-CHECK     : OK

DSC FREQUENCY   TX: 2177.0 kHz
                 RX: 2177.0 kHz
```

Sample Received Message  
Printout (Individual)

```
***** Send message *****
FORMAT          : INDIVIDUAL CALL
ADDRESS         : 111660000
CATEGORY       : ROUTINE
SELF-IDENTITY   : 987654321
1st TELECOMMAND : J3E TELEPHONE
2nd TELECOMMAND : NO INFORMATION
WORKING FREQUENCY : NO INFORMATION
END OF SEQUENCE  : ACK. RQ

DSC FREQUENCY   TX: 2177.0 kHz
                 RX: 2177.0 kHz
```

Sample Send Message  
Printout (Individual)

```
*Transmitted message at JAN-08-1999-16:10:12 *
FORMAT          : INDIVIDUAL CALL
ADDRESS         : 987654321
CATEGORY       : ROUTINE
SELF-IDENTITY   : 111660000
1st TELECOMMAND : J3E TELEPHONE
2nd TELECOMMAND : NO INFORMATION
WORKING FREQUENCY : NO INFORMATION
END OF SEQUENCE  : ACK. RQ

DSC FREQUENCY   TX: 2177.0 kHz
                 RX: 2177.0 kHz
```

Sample Transmitted Message  
Printout (Individual)

**Note:** Messages are not framed in actual printouts.

## 7.8 Scan Freq Menu

The Scan freq menu determines which DSC routine and distress frequencies to scan. Follow the instructions below to select/deselect DSC routine and distress frequencies to scan.

### 7.8.1 Distress frequencies

1. Press the [# / SETUP] key, select SCAN FREQ and press the [ENT] key to display the SCAN FREQ menu.

** Scan freq setup *	
ROUTINE	DISTRESS
<b>F1 : 2M-INTL</b>	2M : FIXED
F2 : 4M-INTL	4M : ON
F3 : 6M-INTL	6M : ON
F4 : 8M-INTL	8M : FIXED
F5 : 16M-INTL	12M : ON
F6 : 25M-INTL	16M : OFF

2. Press ► to shift the cursor to the DISTRESS column.
3. Select the frequency to process and press the [ENT] key. For example, select 4 MHz.

** Scan freq setup *	
ROUTINE	DISTRESS
F1 : 2M-INTL	2M : FIXED
F2 : 2M-USR3	<b>4M : ON</b>
F3 : 4M-INTL	6M : OFF
F4 : 8M-INTL	8M : FIXED
F5 : 16M-LCL1	12M : ON
F6 : 25M-LCL2	16M : OFF

4. Select ON or OFF as appropriate and press the [ENT] key.
5. Press the [CANCEL] key twice to return to the DSC standby screen.

**Note:** Regulations require that 2 MHz and 8 MHz be watched continuously. These frequencies cannot be turned off. Maximum three bands may be turned off.

## 7.8.2 Routine frequencies

1. Press the [# / SETUP] key, select SCAN FREQ and press the [ENT] key to display the Scan freq menu.

** Scan freq setup *	
ROUTINE	DISTRESS
F1 : 2M-INTL	2M : FIXED
F2 : 4M-INTL	4M : ON
F3 : 6M-INTL	6M : ON
F4 : 8M-INTL	8M : FIXED
F5 : 16M-INTL	12M : ON
F6 : 25M-INTL	16M : OFF

2. Select the frequency to process and press the [ENT] key. For example, select 2 MHz.

** Scan freq setup *	
ROUTINE	DISTRESS
OFF	2M : FIXED
F1 : 2 MHZ	4M : ON
F2 : 4 MHZ	6M : ON
F3 : 6 MHZ	8M : FIXED
F4 : 8 MHZ	12M : ON
F5 : 16M-INTL	16M : OFF
F6 : 25M-INTL	

Use ▼ to scroll the menu.

▲
12 MHZ
16 MHZ
22 MHZ
25 MHZ
OTHER

3. Press the [ENT] key, and the display looks something like the one below.

** Scan freq setup *	
ROUTINE	DISTRESS
INTL :T12577.5/R12657.0	
LOCAL1 :T12578.0/R12657.5	
LOCAL2 :T12578.5/R12658.0	
▼	
F6 : 25M-INTL	16M : OFF

4. Select frequency desired and press the [ENT] key. INTL are international channels and LOCAL1/LOCAL2 are local channels. Pressing ▼ selects USER CH, for entry of user channels (where permitted). Note that selecting OTHER at step 2 displays “\*\*M”.
5. Press the [CANCEL] key twice to return to the DSC standby screen.

## 7.9 User CH Menu

The User ch menu allows registration of user Tx and Rx channels, where permitted by the Authorities. Follow the instructions below to register user channels.



1. Press the [# / SETUP] key, select USER CH and press the [ENT] key to display the User ch entry menu.

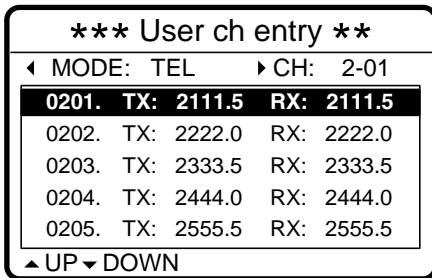

2. Press ◀ to select MODE and press the [ENT] key.

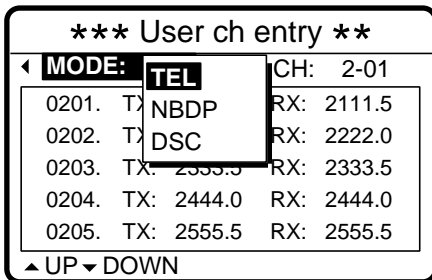

3. Select appropriate mode and press the [ENT] key.
4. Press ▶ to select CH and press the [ENT] key.

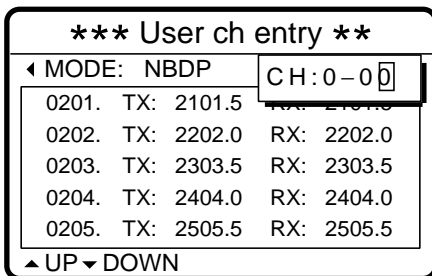

256 channels may be registered.

Band no. setting range is 0-29 and band channel no. range is 01-99.

For DSC, four channels can be registered per band (2, 4, 6, 8, 12, 16, 18, 22, 25).

"0" band is for DSC frequencies only, and they are registered under "OTHER."

- Key in channel no. and press the [ENT] key. For example, press [1], [2], [3], [4] and [ENT] to enter channel 1234. The channel selected is shown in black on white characters at the top of the screen.

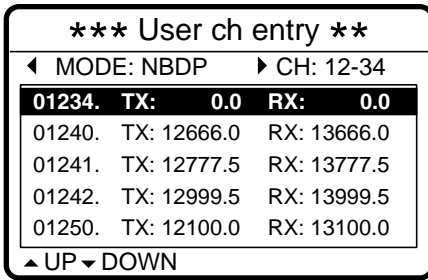

- Press the [ENT] key Enter Tx and press ▼ . Enter Rx frequency and press the [ENT] key. For example, enter 12345.5 kHz as the Tx frequency and 13456.0 kHz as the Rx frequency.

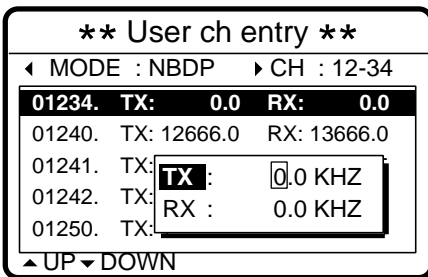

- The display shows the information entered. Using the examples mentioned in this procedure, Tx frequency 12345.5, Rx frequency 13456.0 are registered to channel 1234.

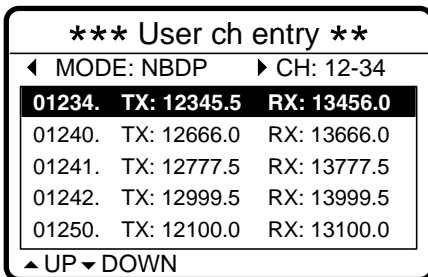

## 7.10 Volume Menu

The Volume menu enables/disables key beep (acknowledges correct key input) and adjusts the volume of the handset, ordinary alarm and distress/urgency alarm. Press the [# / SETUP] key, select VOLUME and press the [ENT] key to display the Volume menu.

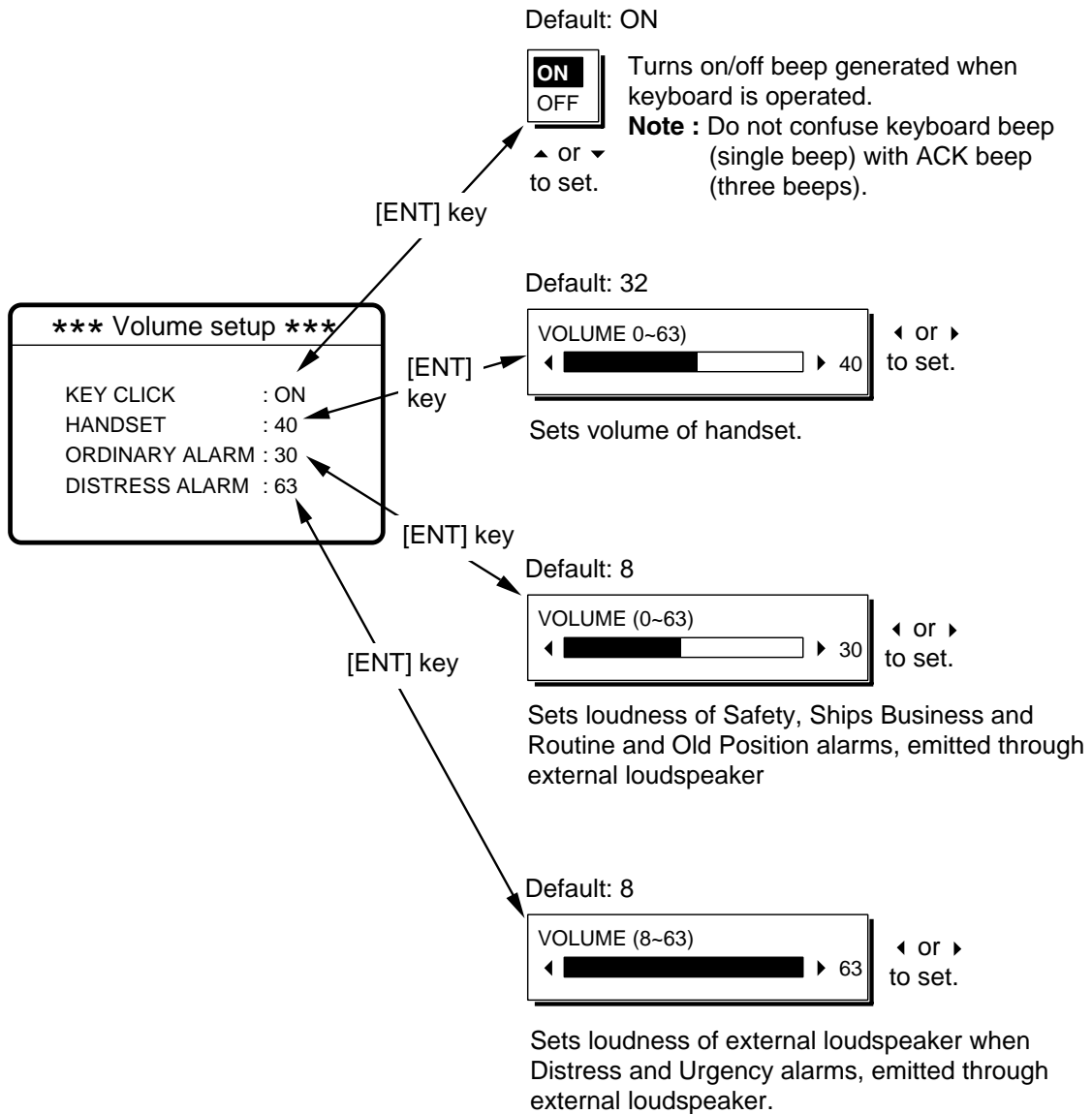



## 7.11 Test Menu

The Test menu provides test facilities for the service technician. This menu cannot be accessed by the operator.

*** Test function **	
TONE	AF PCB
BK	CONT PCB
REMOTE	PANEL PCB
EXT ALARM	RX PCB
EXT ALERT	TA TEST
<b>PROTECTION: ON</b>	

## 7.12 System Menu

The System menu sets up the equipment and is for use by service technicians. This menu cannot be accessed by the operator. However the operator can view the settings by using ▲ and ▼.

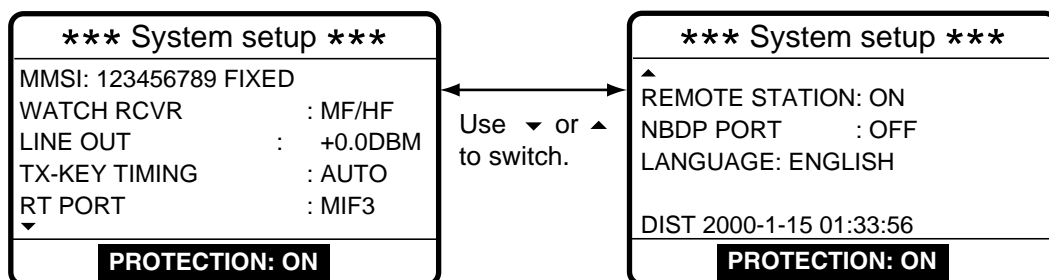

This page is intentionally left blank.

# 8. CHECKING, MAINTENANCE

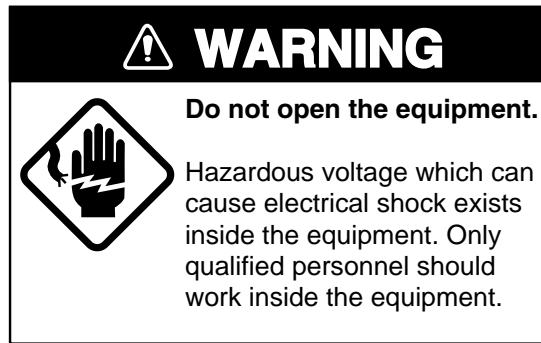

## 8.1 Daily Test

Authorities require that the equipment be checked daily for proper operation to ensure that it will function properly in the event of distress. Execute the daily test as below.

1. At the DSC standby screen or radiotelephone setting screen, press the [3/TEST] key to start the test.
2. After several seconds the test results appear followed by the audio alarm. OK denotes normal operation, and NG (No Good), error. For NG (No Good) contact your dealer for advice.

```
**DSC-60 daily test **
JAN-01-2000-15:24
MAIN CPU   : OK VER.XX*
MODEM      : OK VER.XX*
RCVR1      : OK
RCVR2      : OK
REMOTE RT  : OK FS1562
REMOTE DP  : OK DP-6
```

MAIN CPU: ROM/RAM test executed and version no. displayed.  
MODEM: DSP ROM and DSC signal loopback tests executed and version no. displayed.  
RCVR1: Distress/safety watch received tested.  
RCVR2: Routine watch receiver (option) tested.  
REMOTE RT: CAID of MIF command sent and received. Name of equipment connected (if FURUNO make) and result appear. (System setting RP PORT must be set for RT or MIF otherwise nothing appears.)  
REMOTE DP: CAID of MIF command sent and received. Name of equipment connected (if FURUNO make) and result appear. (Nothing appears when system setting NBDP PORT is OFF.)  
Alarm: Distress alarm sounds for two seconds after completion of test.

\* XX = Version number

3. If auto printing is active the test results are printed. To manually print results, press the [8/PRINT] key. Below is a sample test results printout.

```
* DSC-60 DAILY TEST *
JAN-01-2000-15:24
MMSI:      123456789
MAIN CPU:  OK VER.XX# # XX = Program Version No.
MODEM:     OK VER.XX#
RCVR1:     OK
RCVR2:     OK
REMOTE RT: OK FS1562
REMOTE DP: OK DP-6
```

4. Press the [CANCEL] key to quit the test and return to the previously used screen.

## 8.2 Maintenance

Regular maintenance is necessary for continued performance. Following the procedures below will help keep the equipment in top operating condition.

### 8.2.1 Preventive maintenance

- Check the following points periodically to ensure proper performance.
- Check that each connector is firmly connected and is clean.
- Check the earth terminal for corrosion. If corroded, clean.

### 8.2.2 Cleaning

Dust on the display unit and display screen may be removed with a soft cloth. Do not use commercial cleaners to clean the display unit - they can remove paint and markings.

## 8.3 Simple Troubleshooting

The table below provides common problems and the means with which to restore normal operation. If normal operation cannot be restored do not attempt to check inside the equipment. Any servicing should be referred to a qualified technician.

Problem	Probable cause	Remedy
Power cannot be turned on.	<ul style="list-style-type: none"> <li>• Mains switchboard may be off.</li> <li>• DC overvoltage input.</li> <li>• Battery may have discharged, or poor contact at terminals.</li> </ul>	<ul style="list-style-type: none"> <li>• Turn on the mains switch</li> <li>• Check supply voltage.</li> <li>• Recharge battery and tighten battery terminals.</li> </ul>
Display indications do not appear but key lamps are lit.	<ul style="list-style-type: none"> <li>• Contrast is too low.</li> </ul>	<ul style="list-style-type: none"> <li>• Press the [9/☉] key followed by ◀ or ▶ to adjust the contrast.</li> </ul>
Power is on but no sound from loudspeaker.	<ul style="list-style-type: none"> <li>• Loudspeaker is off.</li> </ul>	<ul style="list-style-type: none"> <li>• Operate the [7/🔊] key to turn on the loudspeaker.</li> </ul>

## 8.4 Error Messages

The table below shows error messages and their meanings.

### Error messages

Error message	Meaning	Remedy
Busy: RT	Radiotelephone is in operation.	Wait till the radiotelephone is free.
EPFS error	No position data from navigator for one minute.	Press the [CANCEL] key to silence alarm. Check the navigator. If it is malfunctioning manually enter position.
No position data	You attempted to enter position automatically when there is no position data.	Check the navigator. See the note at the bottom of page 3-3 for details.
No response: RT	Radiotelephone not powered or has been disconnected.	Check radiotelephone.
Printer not ready	Appears if printer is not powered or has been disconnected and automatic printing is selected.	Check printer.
Warning: Update position	Position data is older by the amount of time preset on the Alarm menu.	Press the [CANCEL] key to silence alarm. Reenter position on the Position menu.

## 8.5 Test Call

This function sends a test signal over one of six distress and safety frequencies to a coast station. For that reason, it should not be executed unnecessarily.

1. Press the [CALL] key at the DSC standby screen, and press the [ENT] key to open the CALL TYPE menu.

*** Send message ***	
<b>CALL TYPE</b>	<b>INDIVIDUAL</b>
STATION ID	PSTN CALL
PRIORITY	TEST CALL
COM TYPE	ALL SHIPS
COM TYPE	GROUP CALL
DSC FREQ	AREA CALL
	POSITION

If this part of the menu appears, use ▲ to scroll.

▲
POLLING
NEUTRAL
MEDICAL
RELAY ALL
RELAY SEL
DISTRESS

2. Use ▲ or ▼ to select TEST CALL and press the [ENT] key.
3. Press the [ENT] key to open the COAST ID menu.

*** Send message ***	
CALL TYPE	: TEST
<b>COAST ID</b>	00000000
PRIORITY	: SAFETY
DSC FREQ	: 2187.5 KHZ
GO TO ALL VIEW	

### How to input coast ID automatically

If you have previously registered some coast IDs, you can insert them into your message as follows:

1. Press the [FILE] key after completing step 2 in the above procedure. The following display appears.

Test ID file	
300. FURUNO	▶
500. MARINE	▶
777. ELECTRIC	▶
▲ UP	▼ DOWN

**Note:** You can print the Test ID file list by pressing the [8/PRINT] key.

2. Select file which contains ID you want to use (press ▶ to show ID number).
3. Press the [ENT] key to insert ID number in message.
4. Key in the ID of the coast station ID (seven digits) to where to send the test call and press the [ENT] key.
5. Press the [ENT] key to open the DSC FREQ menu. (Note that PRIORITY is automatically selected to SAFETY.)

*** Send message ***	
CALL TYPE	<b>2187.5</b>
COAST ID	4207.5
PRIORITY	6312.0
	8414.5
	12577.0
	16804.5
<b>DSC FREQ</b>	MANUAL
	KHZ

**MANUAL:** For selection of frequency at radiotelephone when there is "remote control error."

6. Select an appropriate frequency and press the [ENT] key, and the display changes as below.

<b>*** Send message ***</b>	
CALL TYPE	: TEST
COAST ID	: 001234567
PRIORITY	: SAFETY
<hr/>	
DSC FREQ	: 2187.5 KHZ
<b>GO TO ALL VIEW</b>	

7. Press the [CALL] key to send the test call (transmission time: about 7 sec.). The display shows "Test call in progress!" while the test call is being transmitted.

<b>Test call in progress!</b>	
TO COAST	: 001234567
SAFETY	
<hr/>	
DSC FREQ	: 2187.5 KHZ
TIME TO GO	: 7S

8. After the test call has been sent, the following message appears.

<b>Waiting for test acknowledgement.</b>	
FROM COAST	: 001234567
SAFETY	
<hr/>	
DSC FREQ	: 2187.5 KHZ
TIME TO GO	: 4M12S

9. One of the following displays appears. ("No response! Try calling again?" appears when the timer counts down to zero, meaning no response from coast station.)

<b>Test acknowledge call received.</b>	
FROM COAST	: 001234567
SAFETY	
NO INFORMATION	
<hr/>	
<b>STOP ALARM</b>	

Test acknowledge received

<b>No response! Try calling again?</b>	
FROM COAST	: 001234567
SAFETY	
<hr/>	
DSC FREQ	: 2187.5 KHZ
<b>CALL AGAIN</b>	

No response to test call

10. Do one of the following depending on the message shown in step 9.

Test acknowledge call received

The audio alarm sounds; press the [CANCEL] key to silence the alarm. The display changes as below.

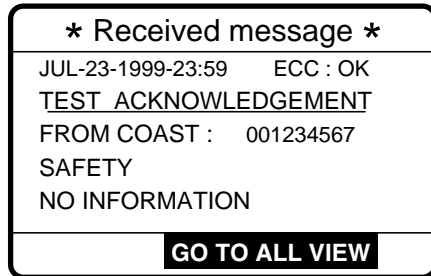

No response! Try calling again?

**Re-send call:** Press the [ENT] key (the display shown in step 6 appears) followed by the [CALL] key to re-send the test call.

**Cancel call:** Press the [CANCEL] key to return to the DSC standby screen.



## Menu Tree

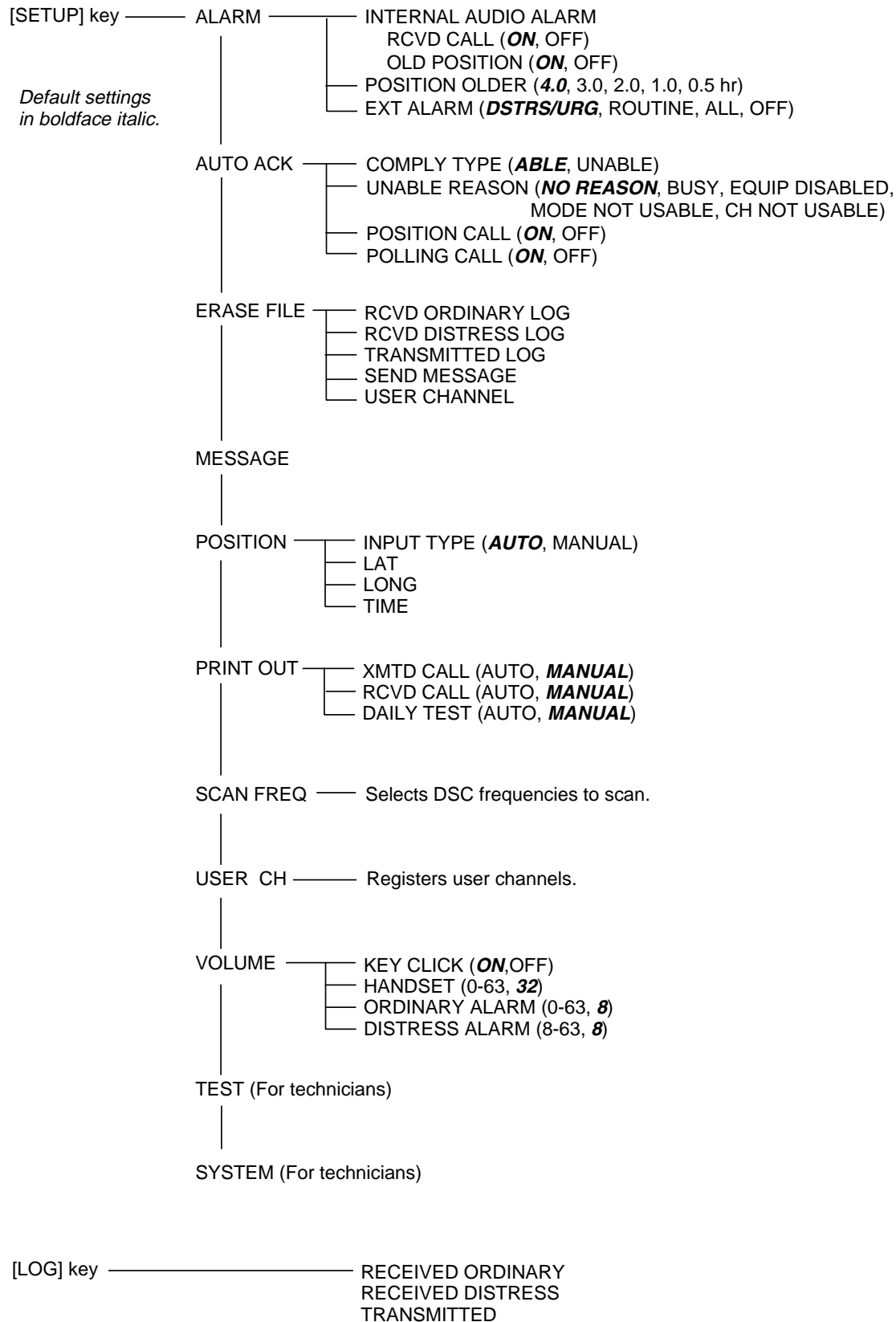

# DSC Frequency Table

Tx (kHz)	Rx (kHz)	Remarks	File Name
2187.5	2187.5	Distress and Safety Frequencies	
4207.5	4207.5		
6312.0	6312.0		
8414.5	8414.5		
12577.0	12577.0		
16804.5	16804.5		
458.5	455.5	International Frequencies	INTL-0.4M
2189.5	2177.0		INTL-2M
4208.0	4219.5		INTL-4M
6312.5	6331.0		INTL-6M
8415.0	8436.5		INTL-8M
12577.5	12567.0		INTL-12M
16805.0	16903.0		INTL-16M
18898.5	19703.5		INTL-18M
22374.5	22444.0		INTL-22M
25208.5	26121.0		INTL-25M
4208.5	4220.0	Local-1 Frequencies	LOCAL1-4M
6313.0	6331.5		LOCAL1-6M
8415.5	8437.0		LOCAL1-8M
12578.0	12657.5		LOCAL1-12M
17805.5	16903.5		LOCAL1-16M
18899.0	19704.0		LOCAL1-18M
22375.0	22444.5		LOCAL1-22M
25209.0	26121.5		LOCAL1-25M
4209.0	4220.5	Local-2 Frequencies	LOCAL2-4M
6313.5	6332.0		LOCAL2-6M
8416.0	8437.5		LOCAL2-8M
12578.5	12658.0		LOCAL2-12M
16806.0	16904.0		LOCAL2-16M
18899.5	19704.5		LOCAL2-18M
22375.5	22445.0		LOCAL2-22M
25209.5	26122.0		LOCAL2-25M

# DSC Regulations

Item	Action initiated by:	Regulations
Initiation of acknowledgement of distress call transmitted on MF or HF band.	Coast	With delay of 1 min to 2 3/4 min (2 min 45 sec) after receipt of distress call.
Initiation of acknowledgement of distress call transmitted on MF or VHF band. (When believing that no coast station is likely to be able to acknowledge it.)	Ship	Wait <u>3 min</u> for distress acknowledge (DIST ACK) signal from coast station. ↓ 3 minutes later ↓ • First: by radiotelephone • Second: by DSC (If acknowledgement by radiotelephone is unsuccessful, use DSC.)
Retransmission (Repetition) of distress alert (until acknowledged).	Ship	At a random delay between 3 1/2 and 4 1/2 min from the first distress call.
Distress relay call on HF band	Ship	Wait <u>3 min</u> for distress acknowledge (DIST ACK) signal from coast station. If no acknowledgement is received within 3 min, no distress relay call from other ship is received and no voice distress communications from other station is received, transmit a distress relay call to the appropriate coast station.
Retransmission of Individual Call.	Ship	Wait <u>5 min</u> for acknowledgement (ACK BQ) signal after transmission of individual call (ACK RQ). If no ACK BQ signal is received within 5 min, you may retransmit the message. Then, wait <u>15 min</u> for ACK BQ signal.
Reply to Individual Call. (ACK BQ transmission)	Coast	With delay of 5 seconds to 4 1/2 min after receipt of Individual Call.

This page is intentionally left blank.

**NBDP**

---

***Part***



# TABLE OF CONTENTS

---

<b>FOREWORD .....</b>	<b>v</b>
<b>1. RADIOTELEX COMMUNICATION</b>	
1.1 General .....	1-1
1.2 Code Description .....	1-1
1.3 ARQ Mode (A-Mode) .....	1-2
1.4 FEC Mode (B-Mode) .....	1-4
<b>2. SYSTEM OVERVIEW</b>	
2.1 System Configuration .....	2-1
2.2 Turning on the System .....	2-2
2.3 Equipment Description .....	2-2
2.4 Function Keys, Menu Operation .....	2-4
<b>3. PREPARATIONS FOR TRANSMISSION AND RECEPTION</b>	
3.1 Registering Answerback Code & ID Codes .....	3-1
3.2 Station List .....	3-3
3.3 Timer Programming .....	3-5
3.4 Scan Channel Groups .....	3-7
3.5 User Channels .....	3-9
<b>4. FILE OPERATIONS</b>	
4.1 Creating Files .....	4-1
4.2 Saving a File .....	4-2
4.3 Editing Files .....	4-3
4.4 Opening Files .....	4-7
4.5 Renaming Files .....	4-8
4.6 Saving a File Under a New Name .....	4-8
4.7 Deleting Files .....	4-8
4.8 Real Time Printing .....	4-9
4.9 Printing Files .....	4-9
4.10 Communications Log .....	4-10
<b>5. TRANSMISSION, RECEPTION</b>	
5.1 Manual Calling .....	5-1
5.2 Calling a Station .....	5-3
5.3 Transmitting a File from a Floppy Disk .....	5-4
5.4 Selecting Receive Mode .....	5-4
5.5 ARQ Mode Operation .....	5-5

5.6 FEC Mode Operation .....	5-7
5.7 Communication Example .....	5-8
5.8 Timer Operation .....	5-11
5.9 Scanning .....	5-12
5.10 Communication Buffer .....	5-12

## **6. WINDOW MENU**

6.1 Window Menu Description .....	6-1
-----------------------------------	-----

## **7. MARITEX OPERATION**

7.1 What is MARITEX? .....	7-1
7.2 Preparations for Transmission .....	7-2
7.3 Preparing Programs for Automatic Message Transmission .....	7-8
7.4 Transmitting in MARITEX System .....	7-17

## **8. MAINTENANCE AND TROUBLESHOOTING**

8.1 Maintenance .....	8-1
8.2 Simple Troubleshooting .....	8-2
8.3 Diagnostic Tests .....	8-2

**ITU TELEX CHANNELS/FREQUENCY LIST ..... AP1-1**

**INTERNATIONAL TELEX ABBREVIATIONS ..... AP2-1**



# FOREWORD

---

FURUNO Electric Company thanks you for selecting and purchasing the FURUNO DP-6 NBDP (Narrow Band Direct Printing) Terminal. We are confident you will discover why the FURUNO name has become synonymous with quality and reliability. To get maximum performance from your unit, please carefully read and follow the recommended procedures for operation and maintenance.

The DP-6 is an advanced, microprocessor controlled NBDP Terminal designed to protect teleprinting communications from radio signal mutilation due to interference in the radio signal path. It provides dependable, fully automatic error-free telex communication with other ships, as well as with any telex subscriber, in full compliance with all GMDSS requirements for automatic radiotelex operation.

The microprocessor used in the DP-6 enables fully automatic operation of your radio station, including automatic frequency scanning, unattended reception and transmission of messages, automatic adjustment of transmitter frequency, and more. Operation is simplified by the use of menus: Simply move the cursor to items on the screen that you want to select.

The DP-6 provides a complete line of word processing facilities in its Text Editor, where you may create, edit and store multiple messages for later transmission.

## Features

- Simple operation by use of pop-up menus
- LCD displays information in easy-on-your-eyes white on black
- Automatic frequency control and message handling permit unattended operation
- Real time printing of incoming messages
- Storage capacity for 100 user channels
- Remote control of a transceiver by commands entered via the keyboard
- Inputs for IEC1162 (NMEA0813) data, to display ship's L/L position, water temperature, and more on the LCD
- Fully automatic radiotelex by use of macro operation

This page is intentionally left blank.

# 1. RADIOTELEX COMMUNICATION

---

## 1.1 General

Telex subscribers can attest to radiotelex as a reliable and efficient method for sending and receiving teleprinter connections. Telex subscribers, especially those who often use HF-band radio circuits, will also attest that the telex connection is subject to interference from a variety of sources, including atmospherics, fading and noise disturbance. This interference plays havoc with radio signals, resulting in the receiving of information different from the intended information. Thus a means must be provided to prevent mutilation of radio signals by interference on HF-band radio.

Radiotelex communication today owes its reliability and efficiency to error detection and correction. The ITU-R defined both a constant-ratio code for automatic error detection and requirements for the error correction in Recommendation 476-3.

## 1.2 Code Description

The DP-6 employs a 7-element synchronous code providing  $2^7 = 128$  combinations. Among these 128 combinations, there are 35 constant-ratio combinations having a ratio of 3 (Y) mark bits to 4 (B) space bits. Thus ratio is used to test the validity of each received character.

Of the 35 combinations, 32 are used for the required alphanumeric teleprinter signals. The remaining three 7-element codes are used exclusively for operational purposes. These are:

Idle Signal  $\alpha$  (ARQ Mode), Phasing Signal 1 (FEC Mode)

Idle Signal  $\beta$

RQ Signal (ARQ mode), Phasing Signal 2 (FEC Mode)

Transmission rate is 100 bauds. If the 4B/3Y ratio is disturbed due to interference, the output of the receiver is blocked to restrict the mutilated character from passing on to the teleprinter.

### Frequency Shift

The frequency shift is 85 Hz with a center frequency of 1700 Hz, as specified in ITU-R Recommendation 476-3.

Space Tone Frequency  $1700+85 = 1785$  Hz

Mark Tone Frequency  $1700-85 = 1615$  Hz

# 1.3 ARQ Mode (A-Mode)

## Description

The ARQ (Automatic Re-transmission request, or Automatic Request for repetition) Mode allows private communications between any two stations using semi-duplex communication. Reception confirmation is done to assure that each character is received correctly. Since the two stations (automatically) exchange identities, this affords some degree of protection for confidential messages.

## Traffic Exchange Sequence

In the ARQ mode two stations communicate directly with one another. One station sends information and receives controls signals, while the other station receives information and sends confirming control signals. The first station is the ISS (Information Sending Station), and the second is the IRS (Information Receiving Station). These functions are interchangeable by a special control signal.

The station which initiates the call is the *Master Station (MS)*. The MS initiates the call by sending the selective identity code of the called station, consisting of an RQ signal and two traffic information signals, listening between blocks.

### Example: Identity Code XQKM



### Example: Identity Code PEARDBY

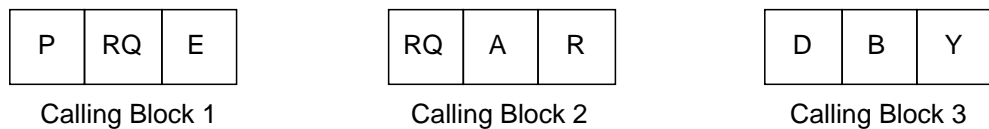

*Figure 1-1 How identity code is transmitted*

The *Slave Station (SS)* recognizes own identity code received and answers it is ready by sending a control signal. The calling station then initiates normal traffic.

The ISS sends information in blocks of three characters. Each character is sent at the rate of 100 bauds, amounting to 70 ms for one character or 210 ms for one character block. The block repetition cycle is 450 ms, so there is 240 ms during each cycle that the ISS is

not sending. This time is taken up by propagation time from the ISS to the IRS, 70 ms for the IRS to send its service information signal, and the return trip back to the ISS.

The IRS listens between blocks and sends a control signal (CS1 or CS2) to request either the next block, or retransmission of the last block in the case of error. Request for retransmission may be repeated up to 32 times, until the completed block has been received error-free. After 32 times, the ISS automatically initiates a new call.

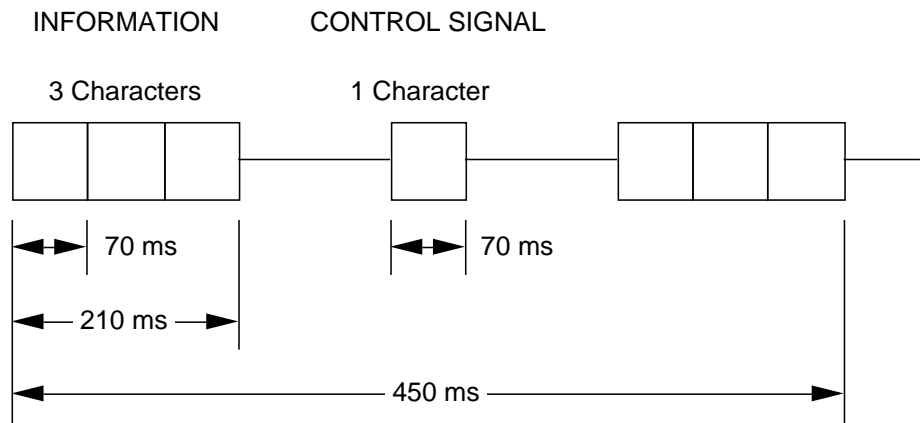

*Figure 1-2 ARQ mode traffic exchange timing*

Once an entire message is received (error-free), a station may switch its function from the IRS to the ISS by means of a control signal (CS3). This change is done by either the ISS by the sequence of "Figure shift + ? ", or by the IRS operator by activating the "OVER" control. Upon receipt of CS3, ISS answers with a  $\beta\alpha\beta$  block. This switches the ISS into IRS. However, the original Master and Slave stations' status remains unchanged, since the Master Station always controls the radio circuit.

## Termination of Communication

Only the ISS may terminate the established circuit. It does this by sending three "idle signals  $\alpha$ ." The IRS and ISS exchange control signals, each reverting to standby after acknowledging each other's control signals. Then, the connection is cleared.

## 1.4 FEC Mode (B-Mode)

### Description

The FEC mode is for one-way, uninterrupted transmission of messages, for example, weather forecasts and emergency bulletins, to no one particular station or stations. The sending station is known as the BSS (B-Mode Sending Station), the receiving station the BRS (B-Mode Receiving Station).

This mode uses a simple forward-error correcting (FEC) technique of sending each character twice at a 280 ms interval. The first transmission is termed DX (direct transmission), the second RX (repeated transmission).

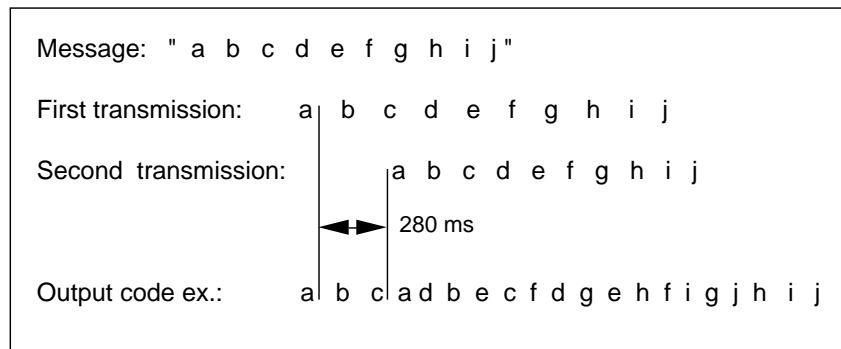

Figure 1-3 FEC mode transmission technique

The receiving station tests the DX and RX characters for adherence to the 4-mark/3-space constant ratio, and prints only unmutated DX or RX characters, or prints a space if both are mutilated.

Another version of the FEC mode is the FEC-selective mode. This mode uses a call code for selective calling to one or more stations. Only those stations with the correct code will receive the data correctly.

### Initiating a Call

When a BSS initiates a broadcast call it transmits synchronizing signals to align phasing of the BRS. Upon detection of this signal the BRS's are switched to the receiving condition and will remain in this condition until the completion of the message. If the mutilated character error rate exceeds a certain percentage, the BRS reverts to standby condition.

### Termination of Communication

The sending station sends three consecutive idle signals  $\alpha$  immediately after the last transmitted information signal in the DX position.

# 2. SYSTEM OVERVIEW

## 2.1 System Configuration

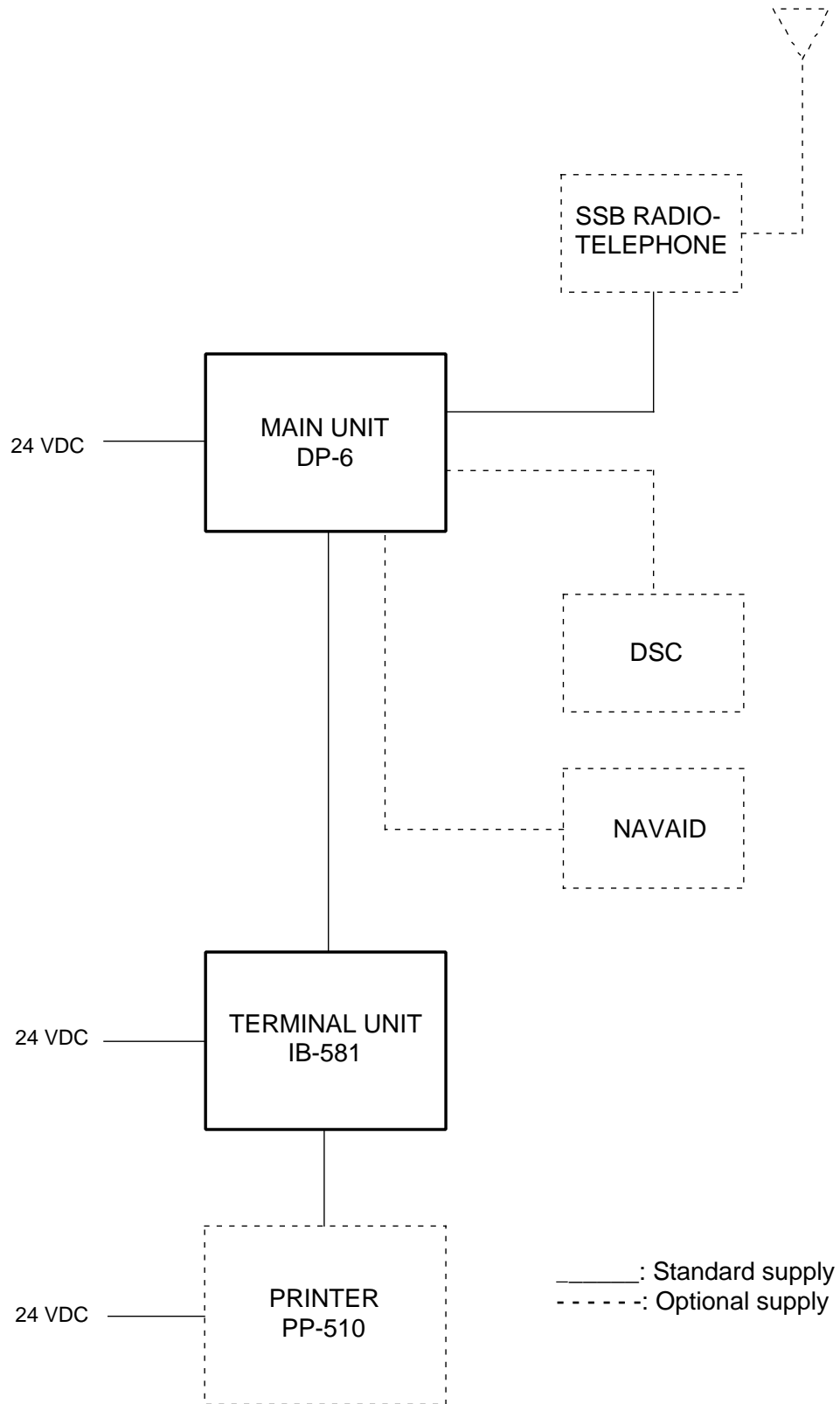

Figure 2-1 System configuration

## 2.2 Turning on the System

There is no particular order for turning on the units of the system. The figure below shows the location of power switches on the units of the system. Note that it takes about six seconds for the LCD to light after the power is turned on.

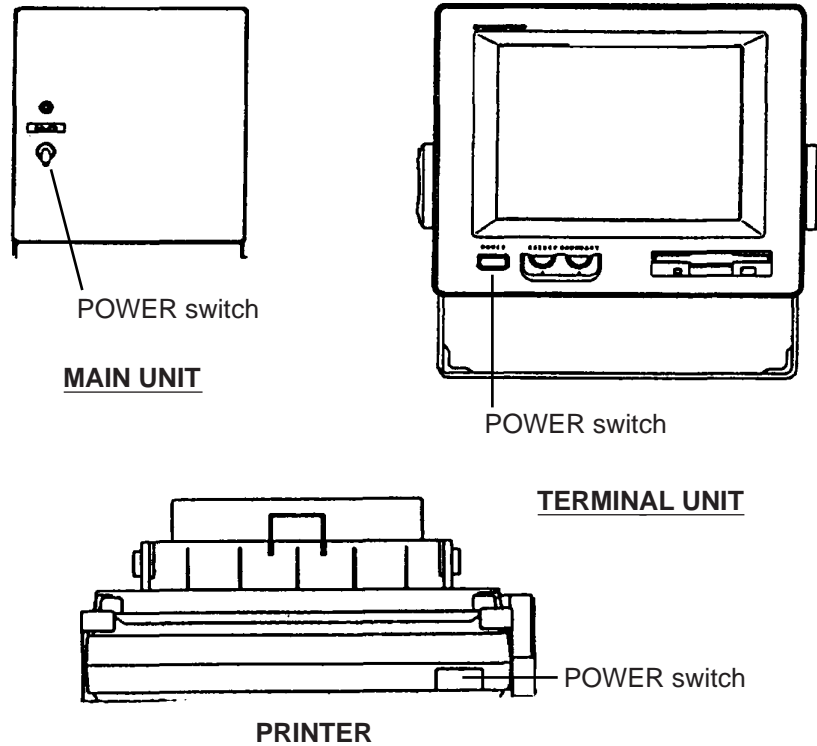

Figure 2-2 Main unit, terminal unit and printer

## 2.3 Equipment Description

### Terminal Unit

The terminal unit consists of a 9" visual display, a floppy disk drive and a keyboard. The floppy disk drive provides for unlimited storage of files on floppy disks. Controls for power and adjustment of display brilliance and contrast are provided on the front panel.

When the terminal unit is turned on the communication status display appears. This is where all phases of communication begin.

```
1:File 2:Edit 3:Operate 4:Window 5:Station 6:System 7:WRU 8:HR 9:Over 10:Break
----- 1996-11-15 13:26:45:45-----Caps-Eng-
Station Name      :
Frequency (T/R)  :          /          (kHz)  Comm Mode : Auto
Comm Status      :  Connect Send Lock Error
Sending Volume   :      (%)  ARQ Error : 0  ARQ Time : 0(sec)
-----
```

Figure 2-3 Communication status display



## Keyboard

unit is operated from the keyboard, and is almost 100% keyboard controlled. Operation is simplified by the use of menus which you access by pressing a function key, numbered F1-F10 at the top of the keyboard. The figure below shows the function menus and their corresponding function keys.

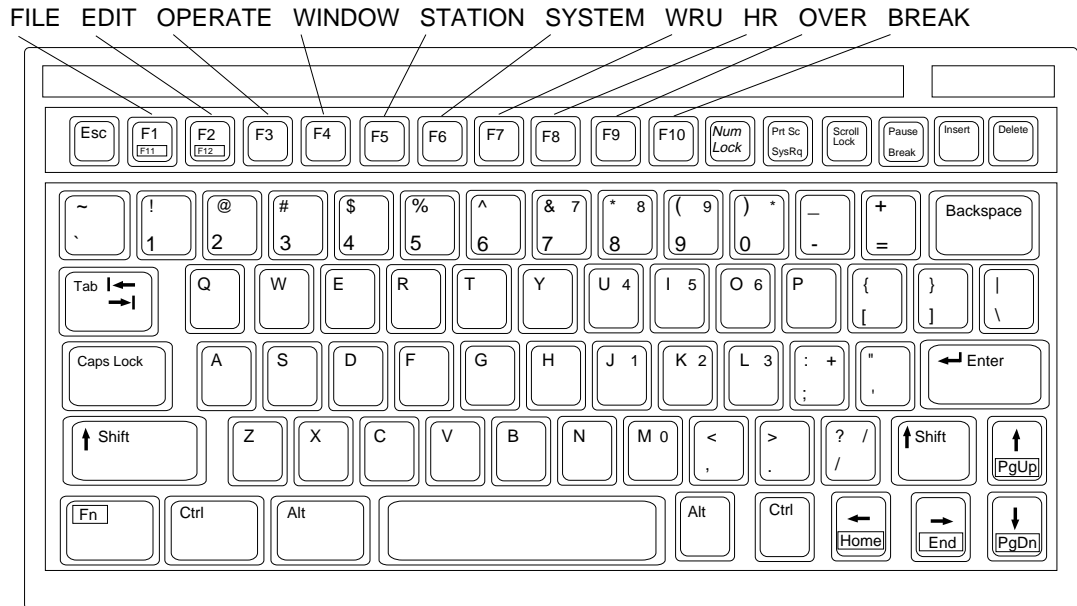

*Figure 2-4 Keyboard*

## **Main Unit**

The main unit mainly acts as the interface between radio equipment, navigator and the terminal unit.

## **Printer (option)**

The printer prints messages. Refer to its operator's manual for operation.

## 2.4 Function Keys, Menu Operation

The function keys at the top of the keyboard control most operations of this unit through a menu system.

### Menu Conventions

#### Inverse video

As you move the cursor down through a menu, selected item initially shown as white on black, inverses to black on white. This highlighting indicates that it is available for selection.

#### Underline

The underline shows current selection. In the figure below, for example, the underline is beneath "Receive".

```
Timer Operation Set Up
Operation      : OP1
Station       : NAGASAKI
Start Time    : 8:35: 0
Stop Time     : 9:10: 0
Receive/Send  : Receive Send
File to send  :
```

*Figure 2-5 The auto operation set up screen*

### Basic Menu Operation

#### Selecting menus

Press appropriate function key to open a menu. To display the File menu, for example, press function key [F1].

```
File
1: New
2: Open
3: Close
-----
4: Delete
-----
5: Rename
-----
6: Real Time Printing
7: File to Print
8: Cancel Printing
-----
9: Clear Buffer
-----
0: Floppy Disk Format
```

*Figure 2-6 File menu*

## Selecting menu items and options

Menu items can be selected by pressing appropriate numeric key or selecting menu desired with the arrow keys and pressing the [Enter] key. Menu options can be selected by operating the [←]/[→] keys. Press the [Enter] key to register selection and close the menu.

## Function Key Description

### Function key [F1]: File menu

The File menu is where you will create, edit, save and print telex messages.

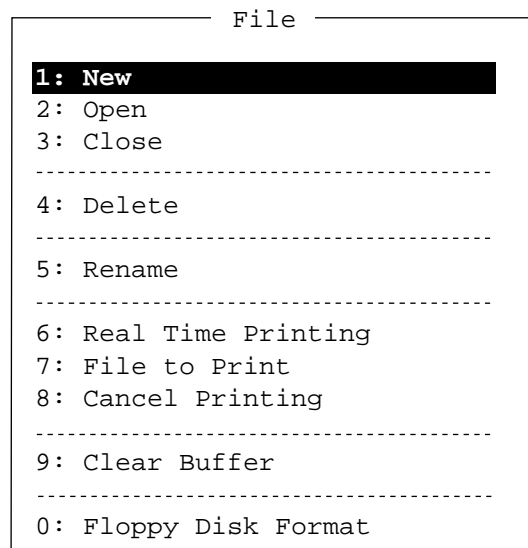
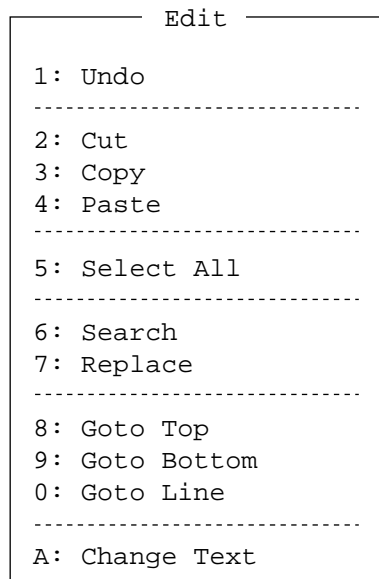

*Figure 2-7 File menu*

<b>1: New</b>	Opens a new untitled window.
<b>2: Open</b>	Opens files.
<b>3: Close</b>	Closes files
<b>4: Delete</b>	Deletes files.
<b>5: Rename</b>	Renames files.
<b>6: Real Time Printing</b>	Turns real time printing on/off.
<b>7: File to Print</b>	Prints files.
<b>8: Cancel Printing</b>	Stops printing.
<b>9: Clear Buffer</b>	Clears the communication buffer.
<b>0: Floppy Disk Format</b>	Formats a floppy disk.

## Function key [F2]: Edit menu

The Edit menu provides a full line of editing features. This menu is only operative while creating a message.

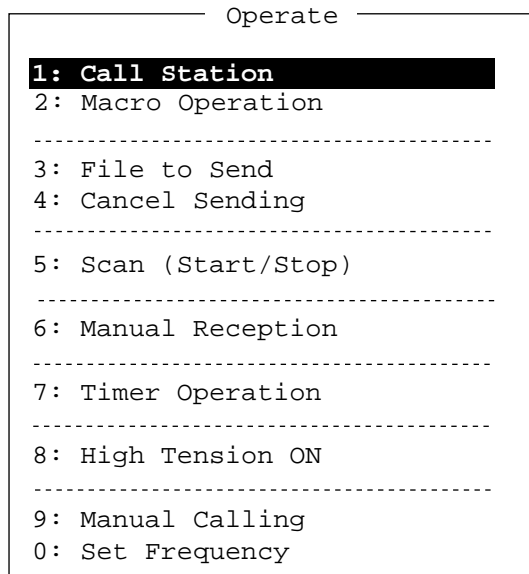

*Figure 2-8 Edit menu*

<b>1: Undo</b>	Cancels the last change (cut, copy or paste).
<b>2: Cut</b>	Removes the selected text and stores it in the paste buffer. (Previous text in the paste buffer is cleared.)
<b>3: Copy</b>	Copies the selected text and stores in the paste buffer. (Previous text in the paste buffer is cleared.)
<b>4: Paste</b>	Inserts the text stored in the paste buffer at the current location of the cursor.
<b>5: Select All</b>	Selects the entire current file for cut and copy.
<b>6: Search</b>	Searches a file for a character string.
<b>7: Replace</b>	Replaces a word with a different word or character string.
<b>8: Goto Top</b>	Brings the cursor to the top line of the current file.
<b>9: Goto Bottom</b>	Brings the cursor to last line of the current file.
<b>0: Goto Line</b>	Moves the cursor to the desired line in the current file.
<b>A: Change Text</b>	Switches between the display window 1 and 2.

## Function key [F3]: Operate menu

The Operate menu controls transmitting and receiving.

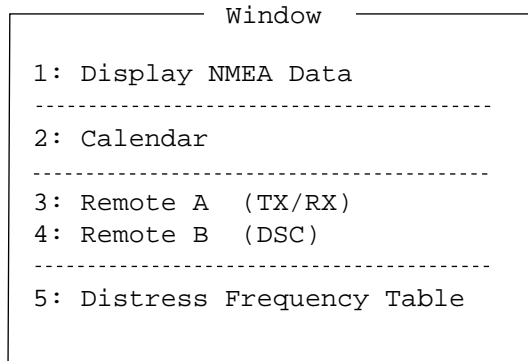

*Figure 2-9 Operate menu*

<b>1: Call Station</b>	Selects a station from the station list.
<b>2: Macro Operation</b>	Enables fully automatic operation.
<b>3: File to Send</b>	Selects a file (to transmit).
<b>4: Cancel Sending</b>	Stops sending a file.
<b>5: Scan Start/Stop</b>	Starts/stops frequency scanning.
<b>6: Manual Reception</b>	Selects communication mode for reception; AUTO/ARQ/FEC.
<b>7: Timer Operation</b>	Timer programming.
<b>8: High Tension ON/OFF</b>	Turns on/off transmitter high voltage on a FURUNO radio.
<b>9: Manual Calling</b>	Sets Tx mode and subscriber's ID number in manual calling.
<b>0: Set Frequency</b>	Sets Tx and Rx frequencies in manual calling.

## Function key [F4]: Window menu

The Window menu displays data together with current screen.

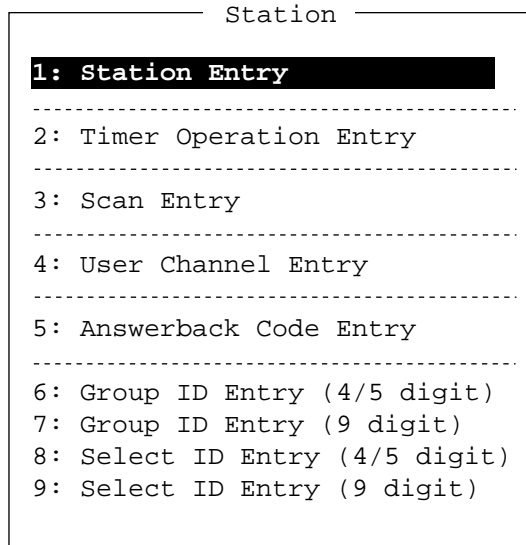

*Figure 2-10 Window menu*

- |                                    |  |
|------------------------------------|--|
| <b>1: Display NMEA Data</b>        | Displays NMEA data: position, speed, Heading, water temperature and depth.   |
| <b>2: Calendar</b>                 | Displays desired calendar month and year.  |
| <b>3/4: Remote A/B</b>             | Entering commands on this screen enables remote control of a FURUNO radio transceiver and DSC terminal connected to Remote A and Remote B terminals. |
| <b>5: Distress Frequency Table</b> | Displays all distress frequencies.   |

## Function key [F5]: Station menu

The Station menu provides for storage of stations, timer programs, channels, and various ID codes.



*Figure 2-11 Station menu*

<b>1: Station Entry</b>	Registers stations.
<b>2: Timer Operation Entry</b>	Registers timer programs.
<b>3: Scan Entry</b>	Creates scan groups for scanning.
<b>4: User Channel Entry</b>	Registers user channels.
<b>5: Answerback Code Entry</b>	Registers own ship's answerback code.
<b>6: Group ID Entry</b>	Registers own ship's group ID codes. (4/5 digit)
<b>7: Group ID Entry</b>	Registers own ship's group ID codes. (9 digit)
<b>8: Select ID Entry</b>	Registers own ship's selective ID codes. (4/5 digit)
<b>9: Select ID Entry</b>	Registers own ship's selective ID codes. (4/5 digit)

## Function key [F6]: System menu

The System menu is mainly for use by technicians and includes diagnostic tests (self test). To change settings, select Change on the Setup line and operate arrow keys to select item and option. Press the [Enter] key to register selection and close the menu.

System	
<b>Setup</b>	<b>Lock</b> Change    Default
Slave Delay	5 msec (0- 50 msec)
BK Timing PreTone	10 msec (0-100 msec)
PostTone	0 msec (0- 20 msec)
Mute Timing PreBK	0 msec (0- 20 msec)
PostBK	0 msec (0- 20 msec)
-----	
Modem Output Level	0 dBm (-30 - +10 dBm)
-----	
MIF Tune	<u>OFF</u> O N
Freeze	<u>OFF</u> O N
AGC	<u>OFF</u> O N
Emission	<u>OFF</u> <u>O N</u>
-----	
TX/RX MSG Save	<u>OFF</u> O N
Edit Before sending	<u>OFF</u> O N
-----	
Time System	OFF <u>UTC</u> SMT JST
Time & Date	1997/3/16/10:00:00
Display Mode	<u>Normal</u> Reverse
Self Test	

Figure 2-12 System menu

<b>Setup</b>	Locks, enables change or restores default system settings.
<b>Slave Delay</b>	Sets the length of the slave delay timing in the ARQ mode.
<b>BK Timing PreTone</b>	Sets the timing for the leading edge of the BK signal in the ARQ mode.
<b>BK Timing PostTone</b>	Sets the timing for the trailing edge of the BK signal in the ARQ mode.
<b>Mute Timing PreBK</b>	Sets the timing for the leading edge of the mute signal in the ARQ mode.
<b>Mute Timing PostBK</b>	Sets the timing for the trailing edge of the mute signal in the ARQ mode.
<b>Modem Output Level</b>	Sets modem output level.
<b>MIF Tune</b>	Turn on to send antenna coupler tuning command. (Requires FURUNO Radio Equipment.)



<b>MIF Freeze</b>	Turn on to send "freeze" command to radio equipment connected. (Requires FURUNO radio equipment.)
<b>MIF AGC</b>	Turn on to automatically control gain in telex mode. (Requires radio equipment which supports AGC command in MIF format.)
<b>MIF Emission</b>	Turn on to automatically change mode at radio equipment to telex. (Requires radio equipment which supports Emission command in MIF format.)
<b>TX/RX MSG Save</b>	Turn on to automatically save incoming and outgoing messages to floppy disk.
<b>Edit Before Sending</b>	"No" transmits keying operation one by one. "Yes" transmits message only when the [Enter] key is pressed after confirming text typed.
<b>Time System</b>	Select Time system. SMT is local time and JST is Japan standard time.
<b>Time &amp; Date</b>	Enter Date and time manually. If a navigation device is connected, the time is automatically set when the power is turned on or whenever the time system is switched. Manual entry takes priority over automatic entry. If there is no the navigation data input, it takes more than extra 10 seconds for automatic initial settings.
<b>Display mode</b>	Select display mode between normal and reverse.

**Function key [F7]: WRU (Who Are You?)**

In the ARQ mode, requests other station's answerback code.

**Function key [F8]: HR (Here Is)**

In the ARQ mode, sends your ship's answerback code.

**Function key [F9]: OVER**

In the ARQ mode, changes the direction of traffic; the information receiving station becomes the information sending station, the information sending station becomes the information receiving station.

**Function key [F10]: BREAK**

Disconnects the communications line.

# 3. PREPARATIONS FOR TRANSMISSION AND RECEPTION

---

This chapter provides the procedures necessary for preparing the DP-6 for transmitting and receiving. For automatic telex, you will need to register the following;

- Your ship's ID and answerback codes
- Stations
- Timer programs
- Scan channel groups
- User channels

## 3.1 Registering Answerback Code & ID Codes

Enter your ship's answerback code and ID code as follows.

**Note:** *The answerback and ID codes cannot be changed once entered; be sure to enter the codes correctly.*

### Registering Answerback Code

1. Press function key [F5] and then the [5] key. The display should look something like Figure 3-1.

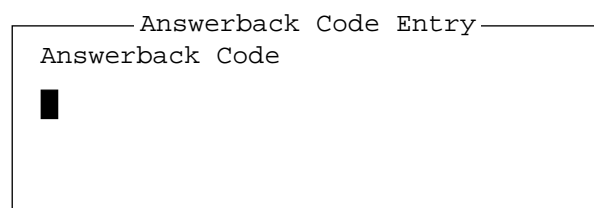

*Figure 3-1 Answerback code entry screen*

2. Enter your ship's answerback code (max. 20 characters, including spaces) and press the [Enter] key. The prompt OK/CANCEL asks for verification of data. If code is correct, press the [Enter] key again.

**Note:** *Example of answerback code 12345789 ABCF X.*

3. For final verification of the data, the Caution shown in Figure 3-2 appears. If code is correct, press the [Enter] key again.

Answerback Code Entry

Answerback Code

123456789 FURU X

OK

Cancel

**Caution**

Confirm the 'CODE' before pressing ENTER key.  
You cannot change the CODE once it has been entered.

*Figure 3-2 Message for confirmation of code entered*

## Registering ID Codes

1. Press function key [F5] and then the [6], [7], [8] or [9] key to enter the Group ID Code (4 or 5 digits), Group ID Code (9 digits), Select ID Code (4/5 digits) or Select ID Code (9 digits), respectively.

Select ID Entry

Select ID Code (4/5)

█

*Figure 3-3 ID code screen*

2. Enter group ID or select ID and then press the [Enter] key. A prompt asks for verification of data. If ID is correct, press the [Enter] key.
3. For final verification of the data, the Caution shown in Figure 3-4. If ID is correct, press the [Enter] key again.

Select ID Entry

Select ID Code (4/5)

12345

OK

Cancel

**Caution**

Confirm the 'CODE' before pressing ENTER key.  
You cannot change the CODE once it has been entered.

*Figure 3-4 Message for confirmation of code entered*

## 3.2 Station List

The station list provides abbreviated dialing with storage for up to 50 stations, one frequency pair (Rx and Tx) per station. For stations which have more than one frequency pair, you might add a suffix to the station name to denote multiple frequency pairs. For example, station name FURUNO followed by -1, -2, -3, etc. for each frequency pair required.

### Registering Stations

1. Press function key [F5] followed by the [1] key. The Station Entry screen appears.

```
Station Entry
-----
Station List
-----
Create
Change

Station Set Up
-----
Station : █
ID Code :
Mode    : ARQ FEC
CH/Table : Channel ScanTable
Num/Table:
```

Figure 3-5 Station entry screen

2. On the right-hand side on the screen you should see Create and Change and Create should be underlined. If it is not, underline it by pressing [→], [↑] and the [Enter] key.
3. The cursor is now on the Station line. Enter station name, using up to 18 characters.
4. Press the [↓] key to go to the ID Code line. Enter station ID code.
5. Press the [↓] key to go to the Mode line. Select communication mode among the following;  
**ARQ:** Automatic Retransmission Request  
**FEC:** Forward Error Correction
6. Press the [↓] key to go to the CH/Table line. Select ScanTable with [→] or [←] key to choose channel.
7. Press the [↓] key to go to the Num/Table line.

8. If you selected "Channel" enter ITU channel number (see appendix) or User channel number (see page 3-9).

If you selected the "ScanTable", press the [→] key to show a scan group list registered (see page 3-7). Select a scan group name by using the [↓] or [↑] key followed by pressing the [Enter] key.

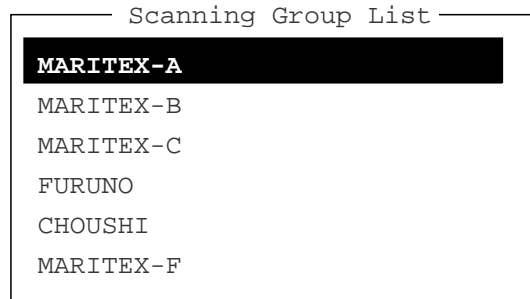

**Note:** *The ScanTable is only available for macro-operation. See page 7-8.*

9. Press the [Enter] key. The prompt OK/CANCEL asks for verification of data.

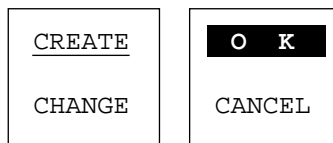

*Figure 3-6 OK/CANCEL prompt*

10. If the data are correct, press the [Enter] key. (To cancel entry, place cursor on CANCEL by pressing the [↓] key, and then hit the [Enter] key. Data entered are erased.)

To register other stations, select Create again and then press the [Enter] key. Repeat steps 3 – 10.

To confirm the data registered, press the [↓] key to get into the Station Set Up window.

**Note:** *If you enter a station which exists the indication "Station by that name already exists. Press any key to escape." appears. Press any key to return to the Station List. Check the list.*

## Editing/Deleting Stations

1. Press function key [F5] and then the [1] key.
2. Select station from the Station List.
3. Select Change and press the [Enter] key.

4. Do one of the following;
  - Edit station:** Use [↑], [↓] and the [Backspace] key to make corrections.
  - Delete station:** Erase station name with the [Backspace] key.
5. Press the [Enter] key twice.
6. Press the [Esc] key.

## 3.3 Timer Programming

A built-in timer allows you to automatically receive and transmit files. 10 timer programs can be registered.

### Registering Timer Programs

1. Press function key [F5]. Press the [2] key to select Timer Operation Entry. The screen should look something like Figure 3-7.

Timer Operation Entry

Timer Operation List

Create  
C

Timer Operation Set Up

**Operation** : █

Station : █

Start Time : 0: 0: 0

Stop Time : 0: 0: 0

Receive/Send : Receive Send

File to Send : █

*Figure 3-7 Timer operation entry screen*

2. If Create is not underlined, press [→], [↑] and the [Enter] key to underline it.
3. Enter a suitable operation name on the Operation line. Any alphanumeric characters may be used. See note 2 on the next page.
4. Place the cursor on the Station line. Press the [→] key to display the Station List. Select a station and press the [Enter] key.

5. Press the [↓] key to advance the cursor to the Start Time line. Enter start time in 24-hour notation. To have the operation start at 8:35, for example, the keying sequence would be;
 

[0] [8] [3] [5] [0] [0]
6. Press the [↓] key to advance the cursor to the Stop Time line. Enter stop time.
7. Press the [↓] key to advance the cursor to the Receive/Send line. Select operation category; Receive or Send.
8. For send, insert floppy disk in drive and designate the file to send. Press the [↓] key to advance the cursor to the File to Send line. Press the [→] key to display the file list, select a file, and press the [Enter] key.
9. Press the [Enter] key.
10. Press the [Enter] key. The operation name appears in the Timer Operation List. See note 2 and 3.

**Note 1:** *To change a timer program, select it on the Timer Operation List, select Change and press the [Enter] key. Enter new data.*

**Note 2:** *If the operation name entered already exists, the display shows the following message: Operation name already exists. Press any key to escape. Press any key and change the operation name.*

**Note 3:** *If the station name entered has not been registered, the display shows the following message: Station by that name does not exist. Press any key to escape. Press any key and register the station as shown on page 3-3.*

## **Editing/Deleting Timer Programs**

1. Press function key [F5] and the [2] key.
2. Select timer program from the Timer Program List.
3. Select Change and press the [Enter] key.
4. Do one of the following;
  - Edit program:** Use [↑], [↓] and the [Backspace] key to make corrections.
  - Delete program:** Erase operation name with the [Backspace] key.
5. Press the [Enter] key twice.
6. Press the [Esc] key.



## 3.4 Scan Channel Groups

The DP-6 can automatically control radio equipment through channel scanning. The radio equipment scans a number of channels (according to your selection), stopping when your own ID code is detected in an incoming signal. The transmitter is tuned to the corresponding transmitter frequency, the communication link is established and the traffic is automatically exchanged. Scanning resumes once the link is disconnected.

You may store a maximum of 10 scan groups, 20 channels per group. Note that scanning is only possible in the ARQ and FEC modes.

### Registering Scan Channel Groups

1. Press function key [F5] followed by the [3] key to display the Scan Entry screen.

The screenshot shows the 'Scan Entry' screen. At the top, it says 'Scan Entry'. Below that, there are two main sections. The first is 'Scanning Group List', which is currently empty. To its right is a box with two options: 'Create' and 'Change', both underlined. The second section is 'Scanning Set Up'. It contains several settings: 'Group Name' (with a cursor on a blank line), 'Ch Dwell Time' (4.5 sec (2.7-4.5 sec)), 'Mode' (AUTO ARQ FEC), and 'Auto Search' (OFF ON). Below these settings is a table with 6 rows. The first five rows are numbered 1 to 5, and the sixth row is numbered 6 with a downward arrow. The columns are 'No', 'Channel', 'Rx Freq', 'Tx Freq', and 'Pass/Scan'. The 'Pass/Scan' column contains the text 'Pass/Scan' for each row, with the 'P' and 'S' underlined.

No	Channel	Rx Freq	Tx Freq	<u>P</u> ass/ <u>S</u> can
1				<u>P</u> ass/ <u>S</u> can
2				<u>P</u> ass/ <u>S</u> can
3				<u>P</u> ass/ <u>S</u> can
4				<u>P</u> ass/ <u>S</u> can
5				<u>P</u> ass/ <u>S</u> can
▼ 6				<u>P</u> ass/ <u>S</u> can

Figure 3-8 Scan entry screen

2. If Create is not underlined, press [→], [↑] and the [Enter] key to underline it.
3. The cursor is on the Group Name line. Enter suitable group name.
4. Press the [↓] key to advance the cursor to the CH Dwell Time line. Enter channel dwell time in seconds. Dwell time is the time in seconds the receiver waits on each channel in a scan group before it selects the next frequency.

5. Press the [↓] key to advance the cursor to Mode, and then select the communication mode; AUTO, ARQ or FEC.

**Note:** *To register the Scanning Channel Group for ARQ, select ARQ. For FEC, select FEC.*

AUTO is used to register scanning channel group when both ARQ and FEC exist in the same Scanning Channel Group.

6. Press the [↓] key to advance the cursor to Auto Search. Select Auto Search to ON or OFF.

**Auto Search ON:** Radio stops scanning when it finds the strongest signal (highest S/N ratio). To find strongest signal, the radio scans all this channel, which may take some time. Therefore, use this setting where signal propagation is poor.

**Auto Search OFF:** Radio stops scanning on the first signal it finds. We recommend that you set Auto Search to OFF where signal propagation is good.

7. Advance the cursor to line no. 1 in the Scanning Set Up window. Enter channel number (ITU or user channels) and press the [→] key to select "Scan".
8. Press the [↓] key to advance the cursor to line No. 2. Enter channel number.
9. Enter other channel numbers and then press the [Enter] key.
10. Press the [Enter] key again to save the data.

To register another scan group, repeat steps 2 – 9.

**Note:** *When the scan group memory is full the DP-6 displays "Scan group information full."*

## **Editing/Deleting Scan Channel Groups**

1. Press function key [F5] and the [3] key. Select scan group from the Scanning Group List.
2. Select Change and press the [Enter] key.
3. Place the cursor on the line (channel) to change.



6. Press the [Enter] key.
7. Press the [Enter] key. Channel number entered appears in the Channel List.

To register another user channel, repeat steps 2 – 7.

### **Editing/Deleting User Channels**

1. Press function key [F5] and then the [4] key.
2. Select channel from the Channel List.
3. Select Change and press the [Enter] key.
4. Do one of the following;
  - Edit channel:** Use [↑], [↓] and the [Backspace] key to make corrections.
  - Delete channel:** Erase channel number with the [Backspace] key.
5. Press the [Enter] key twice.
6. Press the [Esc] key.

# 4. FILE OPERATIONS

---

This chapter mainly describes how to create, save, edit and print files. The Edit menu provides a full lineup of editing facilities including search and replace.

## 4.1 Creating Files

1. Press function key [F1] to display the File menu.



*Figure 4-1 File menu*

2. Press the [1] key.
3. Type your message.

**Note:** Do not use lower case letters, #, &, \*, \$ or % in telex messages. Also, do not put “\$\$\$” (three successive \$s) in the middle of a Tx message, but at the end. The communication line is automatically disconnected when the DP-6 detects this string.

## 4.2 Saving a File

Before you can save a file to a floppy disk, the disk must be formatted. 2HD Type is only available.

### Formatting Floppy Disks

1. Press function key [F1].
2. Press the [0] key to select "Floppy Disk Format".
3. Press the [↑] key to select "YES".
4. Press the [Enter] key.
5. Insert a new floppy disk and press the [Enter] key.

### Saving a File

1. Press function key [F1] to display the File menu.
2. Press the [3] key. The screen should look something like Figure 4-2.

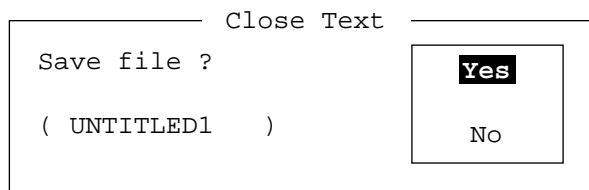

Figure 4-2 Close text screen

3. Press the [Enter] key. Enter file name, using up to eight characters.

You may use any alphabet or numeric on the keyboard. But you may not use the following punctuation symbols;

| ! : " > < ;

You may add an extension at the end of the file name, for example, .TXT, to distinguish text file from macro file.

4. Press the [Enter] key.

**Note:** When the working area is full, the message "File can't open" appears. Then, you would close a file to clear a working area in order to open the file desired.

## 4.3 Editing Files

### Cutting and Pasting Text

You can delete, move and copy text by using the Cut, Copy and Paste functions in the Edit menu.

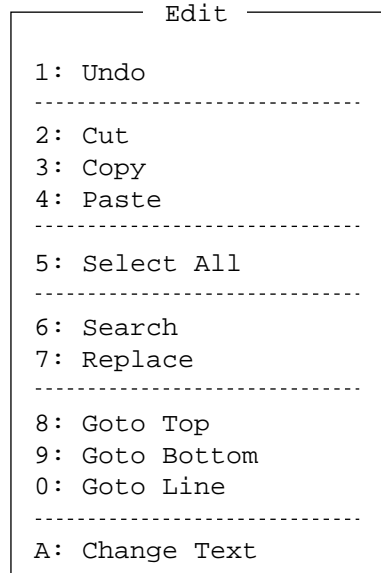

*Figure 4-3 Edit menu*

### Cutting text

1. Place the cursor on the first character of the text to be cut.
2. Highlight the text to be cut by pressing and holding the [Shift] key while pressing the [→]. If you highlight text which you do not want to cut, press the [←] to adjust the highlight.

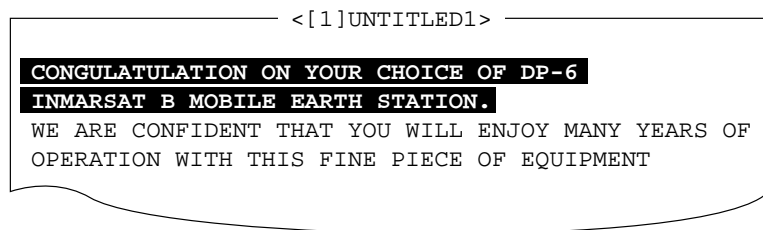

*Figure 4-4 The highlight*

3. Press function key [F2] and the [2] key. The highlighted text is cut and the remaining text is reformatted.

If a mistake is made, you can restore the text by immediately selecting Undo in the Edit menu.

## **Pasting text**

To paste the cut text to a new location;

1. Place the cursor at the exact spot in the message where the cut text is to start.
2. Press function key [F2] and the [4] key.

## **Copying and Pasting Text**

You may copy a portion of text and paste it elsewhere.

1. Select the text to copy (see the "cutting" procedure above ).
2. Press function key [F2] and the [3] key.

The text selected is copied in the paste buffer memory where the cut or copied text is stored. The display returns to the normal screen.

3. Place the cursor at the exact spot in the message where the copied text is to start.
4. Press function key [F2] and the [4] key.

## **Clearing the Paste Buffer**

Press function key [F1] and the [9] key.

## **Undo**

Use the Undo feature to return the file to its most recent state. For example, you have cut text but want to restore it. Then, you would select Undo in the Edit menu to restore the text to its most recent location.

## **Select All**

The Select All feature lets you select all of the file currently displayed. This feature can be useful when you want to combine files. The procedure below explains how to tack the file loaded in working memory 1 onto the end of the file loaded in working memory 2.



1. Load the file to be copied from a floppy disk in working memory 1.
2. Press function key [F2] and the [5] key. The entire file appears in inverse video.
3. Press function key [F2] and the [3] key. The file is placed in the paste buffer memory.
4. Load the file to be combined in working memory 2.
5. Place the cursor at the exact spot in the message where the text now in the paste buffer memory is to start and press the [Ins] key.

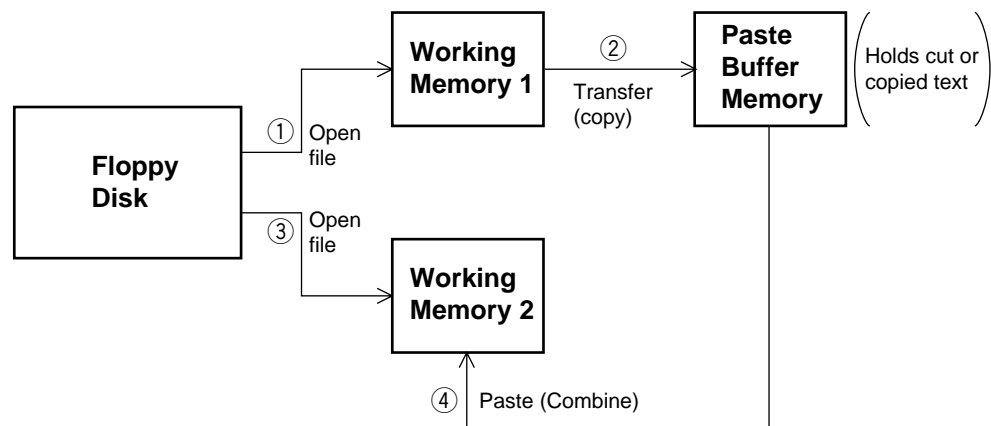

Figure 4-5 Cut and paste flow diagram

## Searching Text

The Search feature lets you search for text in a forward or backward direction.

1. Display a text and press function key [F2] and the [6] key. The Search display appears.

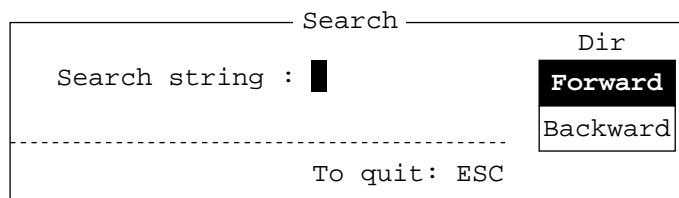

Figure 4-6 Search screen

2. Type the word you want to find. Select Forward or Backward to search the file in a forward or backward direction respectively from the cursor position. Press the [Enter] key to begin the search.

When the unit finds the word, the cursor stops at the first character of the word. Press the [Enter] key to continue the search.

## Replacing Text

The Replace feature helps you replace every occurrence of a word or phrase with another word or phrase in a file.

1. Press function key [F2] and the [7] key. The Replace display appears.

Replace		Dir	Mode
Search string :	█	Forward	Query
Replace with :		Backward	All
-----			
To quit: ESC			

*Figure 4-7 Replace screen*

2. Type the word you want to replace on the "Search string " line.
3. Press the [↓] to select "Replace with." Type the new word.
4. Select Forward or Backward to search the file in a forward or backward direction respectively from the cursor position.
5. Select whether you want to be queried or not each time the word is found.

**Query:** Stop at each occurrence of word to answer yes or no to replacement.

**All:** Replace every occurrence of word without stopping to confirm.

6. Press the [Enter] key to start the replacement.

## Goto Line

This feature places the cursor at the head of a line desired. Press function key [F2] and the [9] key. The following display appears.

Goto Line
Jump to Line No. : _____

*Figure 4-8 Goto line screen*

Key in line number and press the [Enter] key. The cursor shifts to the head of the line selected.

## 4.4 Opening Files

Two working areas (called working area 1 and working area 2) are provided to which you can load a file, and one file may be displayed on the LCD.

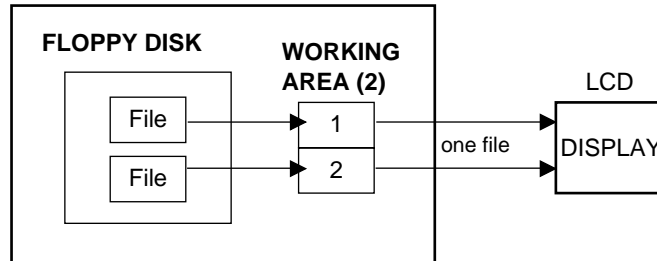

*Figure 4-9 Working memories*

### Opening a File

1. Press function key [F1] to display the File menu.
2. Press the [2] key. A chronological list of files on the floppy disk appears.
3. Select a file. Press the [Enter] key.

The file appears and the title bar shows the file name. You may repeat this procedure to load another file into a working area.

### Switching Between Files

Two files can be opened and one displayed on the LCD. To switch between files do the following;

1. Press function key [F2].
2. Press the [A] key to switch files.

## 4.5 Renaming Files

To rename a file;

1. Press function key [F1].
2. Press the [5] key.
3. Select file and press the [Enter] key.
4. Enter new name.
5. Press the [Enter] key.

## 4.6 Saving a File Under a New Name

You may save a file under a new name as follows;

1. Open a file.
2. Edit the file as necessary.
3. Press function key [F1].
4. Press the [3] key to clear the screen.
5. Press the [Y] key.
6. Press the [Backspace] key to erase the original name and then enter a new name.
7. Press the [Enter] key.

## 4.7 Deleting Files

1. Press function key [F1].
2. Press the [4] key.
3. Select file to delete and then press the [Enter] key.
4. Press the [Enter] key again. (To cancel, press the [↓] key followed by the [Enter] key.)

## 4.8 Real Time Printing

An incoming or outgoing message can be printed out while it is being received or transmitted.

1. Press function key [F1] to display the File menu.
2. Press the [6] key to turn real time printing on/off.

PRINT appears in inverse video when real time printing is on.

## 4.9 Printing Files

You can print a file as follows;

1. Press function key [F1].
2. Press the [7] key.
3. Select file and press the [Enter] key.
4. Press the [Y] key.

If the file could not be printed, "Cannot print. Check connection between printer and terminal. Press any key to escape." is displayed.

## 4.10 Communications Log

Transmission/Reception date and time, ID, mode, Tx/Rx frequencies and station name are recorded for each message received or transmitted. ("TX/RX MSG Save" must be ON in the System menu to automatically save Tx and Rx messages.)

### Displaying the Communications Log (Log File)

1. Press function key [F1] and then the [2] key.
2. Select Log File and press the [Enter] key. A list of Tx and Rx messages appears. See Figure 4-10.

**Note:** *The Log File can store about 230 communication files. When it becomes full, an error message appears to alert you. If this occurs, delete all log files.*

```
----- Open Text -----
Load/Merge (TAB:Change)
-- File Name-----Size--Date & Time-----
LOG FILE          95k 96-12-13 14:20
TELEX              136k 96-01-08 20:32
NBDP               28k 96-01-09 20:31
DO-5               41k 96-02-12 20:30

File Count : 4  Memory : 4k Used 96k Available
```

```
----- [1]B:\LOG_FILE -----
```

Date	Time	Mode	ID	TX Freq.	RX Freq.	Station name
12-13	14:17 14:19	FEC	1234	8765.00	8965.00	CHOUSHI-8M
12-13	14:19 14:20	FEC	1234	8765.00	8965.00	CHOUSHI-8M
12-13	14:20 14:23	FEC	1234	8765.00	8965.00	CHOUSHI-8M

Figure 4-10 Log file

### Printing the Log File

1. Press function key [F1] and then the [7] key.
2. Select Log File and press the [Enter] key.
3. Press the [Y] key.

# 5. TRANSMISSION, RECEPTION

This chapter shows you how to transmit and receive Telex messages. Also included are the procedures for frequency scanning, and automatic operation.

## 5.1 Manual Calling

The simplest way to communicate with a Telex subscriber is Manual Calling. For the ARQ mode, you may display beforehand the message to send or type message manually.

1. Press function key [F3] to display the Operate menu.

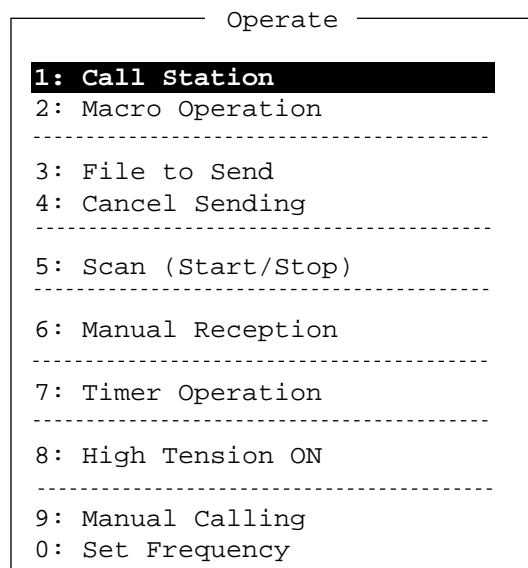

Figure 5-1 Operate menu

2. Press the [0] key. The Set Frequency screen appears.

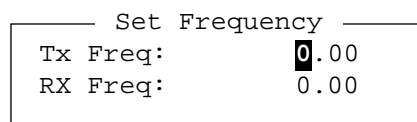

Figure 5-2 Set frequency screen

3. Input frequency pair. This can only be done with FURUNO transceivers.

For other makes of transceiver, set a frequency pair at the transceiver. Omit steps 1, 2 and 3.

4. Press the [Enter] key.
5. Press function key [F3] again and then the [9] key. The following screen appears.

```
— Manual Calling —  
Mode : ARQ FEC  
ID   :
```

*Figure 5-3 Manual calling screen*

6. Select communication mode.
7. Press the [↓] key and input party's ID number.
8. Press the [Enter] key to connect the communication line. Then, the line will be connected a short while.

For ARQ mode, follow the next procedure. For FEC mode, type your message and go to step 13.

9. Press function key [F7] (WRU). The party's answerback code appears on the screen.

**Note:** *Step 9 and 10 are needed for ship to ship calling only.*

10. Press function key [F8] (HR). You ship's answerback code is sent to the party.
11. Press the [Enter] key and type your message.
12. If you want to the party's response, press function key [F9] (Over).
13. Press function key [F10] to disconnect the line.



## 5.2 Calling a Station

1. Press function key [F3] to display the Operate menu.

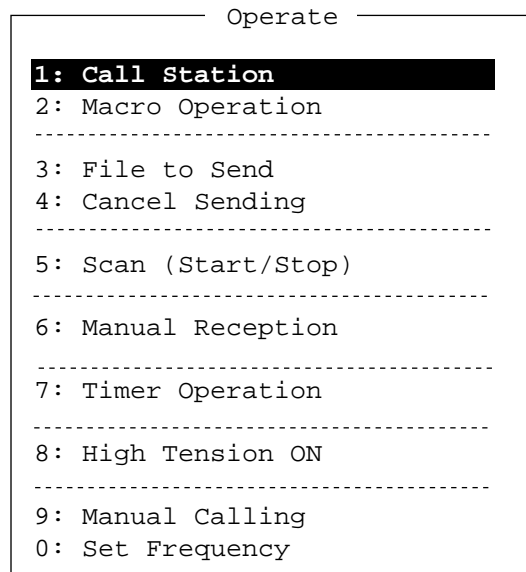

*Figure 5-4 Operate menu*

2. Press the [1] key to display the Station List.
3. Select the station you wish to call.
4. Press the [Enter] key to establish connection with the station.

```
1:File 2:Edit 3:Operate 4:Window 5:Station 6:System 7:WRU 8:HR 9:Over 10:Break  
----- 1996-11-15 14:28 (JST) ----- Caps  
Station Name      : CHOUSHI-8M  
Frequency (T/R)   : 8765.00 / 8965.00(kHz)  Comm Mode :ARQ  
Comm Status       : Connect Send Lock Error  
Sending Volume    : 100(%)  ARQ Error : 0  ARQ Time : 0(sec)  
-----
```

*Figure 5-5 Communication status display*

"Connect" appears in inverse video on the Comm Status line when an acknowledge signal from the station called is detected. (In the ARQ mode connection may be delayed due to signal condition. In the FEC mode, however, "Connect" appears in inverse video a few seconds later since the acknowledge signal is not required.)

## 5.3 Transmitting a File from a Floppy Disk

You may send a file from a floppy disk as follows after calling a station.

1. Press function key [F3] and then the [3] key.
2. The Send screen appears.

Send File			
File Name	Size	Date & Time	
<b>LOG FILE</b>	1k	1996/11/15	14:23
TELEX	1k	1996/11/15	20:32
NBDP	1k	1996/11/15	20:31
DO-5	1k	1996/11/15	20:30

To select : ENTER To view : SPACE To quit : ESC

Figure 5-6 Send file screen

3. Select the file you wish to send. Then, press the [Enter] key to transmit the file.

### Stopping Transmission

1. Press function key [F3] and then the [4] key.
2. Send Canceled appears on the screen. Transmission is stopped but the line is still connected.

## 5.4 Selecting Receive Mode

1. Press function key [F3] and then the [6] key.
2. Select receive mode;
  - AUTO:** Automatic operation in ARQ and FEC
  - ARQ:** International radiotelex ARQ mode
  - FEC:** International radiotelex FEC mode
3. Press the [Enter] key. The reception mode appears on the screen.

All received (and transmitted) messages are saved to a floppy disk when "Tx/Rx Msg Save" is ON in the System menu. The file is named as follows.



4. Transmit message by one of the following methods;

**Send a file from a floppy disk**

- a) Press function key [F7] (WRU) to receive the answerback code of the other station. Verify that the code from the station called is correct.
- b) Press function key [F8] (HR) to transmit your own identity (answerback code).
- c) Press function key [F3] and then the [3] key to display the Send screen. Select file to send and press the [Enter] key. Send appears in inverse video while the file is being transmitted.

```
----- Send File -----
----- Filename -----Size----- Data & Time-----
<Parent Directory>          96-11-15 12:24
00FOX .MES                   95  96-11-15 08:07
ASCII .TXT                   613 96-11-15 16:15
BEEP .EXE                   28854 96-11-15 10:36
DPX .AUT                    1830 96-11-15 10:02
DPX .BAT                     349 96-11-15 13:54
DPX .BSC                    28000 96-11-15 17:11
DPX .CNL                    1000 96-11-15 10:02
  29 Files exist          247271424 bytes free
-----
To select:ENTER  To view:SPACE  To quit:ESC
```

Figure 5-8 Send file screen

Sending volume (percentage of message transmitted, counts upward as the message is being transmitted), ARQ error count and ARQ transmission time appear on the display.

```
1:File 2:Edit 3:Operate 4:Window 5:Station 6:System 7:WRU 8:HR 9:Over 10:Break
----- 1996-11-15 14:28 (JST) ----- Caps
Station Name      : CHOUSHI-8M
Frequency (T/R)  : 8765.00 / 8965.00(kHz)  Comm Mode :ARQ
Comm Status      : Connect Send Lock Error
Sending Volume   : 100(%)  ARQ Error : 0  ARQ Time : 0(sec)
-----
```

Figure 5-9 Communication status display

**Type a message from keyboard**

After exchanging answerback code by the function key [F7] (WRU) and [F8] (HR), type your message directly from the keyboard.

- 5. To change direction of traffic, press either function key [F9] (OVER), or [+] and [?]. Then, the other station becomes the information sending station, your station the information receiving station.

6. Receive a message from the sending station, if any.
7. After completion of communication, press function key [F7] (WRU) key to receive the answerback code of the other station and then press function key [F8] (HR) key to transmit your own answerback code.
8. Press function key [F10] (BREAK) to disconnect the line.

## 5.6 FEC Mode Operation

The FEC method of error correction is used when there is more than one receiving station, and no replies are required by the other station. Each message is sent twice, the characters of the first message interleaved with those of the second. The receiving station thus has two chances to receive each character correctly. If both characters are in error, an asterisk (\*) is printed.

1. Press function key [F3].
2. Press the [1] key to display the Call Station menu.
3. Select a station which is registered for the FEC mode. Press the [Enter] key. CONNECT lights in inverse video.
4. Transmit message from a floppy disk as follows.  
Press function key [F3] and the [2] key to open the Send screen. Select file to send and press the [Enter] key.
5. After the message is transmitted, press function key [F10] (BREAK) to disconnect the line.

## 5.7 Communication Example

This section shows how to register your station with a coast station (Singapore), in order to connect with a land line and send messages to other stations.

Contact the coast station following the procedure on page 5-3. Then, register your station's name, call sign, answerback code and selcall number and AAIC (Accounting Authority Identification Code) with the coast station.

You can call the Singapore coast station on ITU channels 809, 821 or 1201 (other channels may also be used). Use communication mode ARQ. The Singapore coast station ID no. is 4620.

### Registration procedure

1. Call Singapore coast station following the procedure on page 5-3.
2. Singapore requests your AAIC.
3. Type your AAIC.
4. Singapore asks for your callsign. Send your station's name, callsign, answerback code and selcall number.
5. Singapore sends time required to register your station.
6. Transmit end code.

9VG SERADIO RS  
12345 FURUNO X  
54321 ABCDE J  
9VG SERADIO RS  
MOM  
F

} Exchange answerback codes

UGOX DE 9VG RGR GA X X PSE SUPPLY YOUR AAIC HW +? ——— Singapore requests your AAIC.

OPR + ——— Call operator.

AAIC AA01 +?

RGR PSE GIVE YOUR SHIP NAME CALLSGI CALLSIGN HW +?

I INTRODUCE MY INFO LATER

PLS AGAIN

} Singapore requests your station's name and callsign.

AAAAAA

CS- 1111

ANSWERBACK CODE- ccccc cccc c

} Enter your stations name, callsign, answerback, code and selcall number.

AAIC- 9999

SELCALL- 56789

OK HW +?

PSE BE SURE W ICH AAIC CFM PSE HW +?

bb01 SO + +?

RGR PSE OFF TX X HERE EEE CALL BACK 2MINS TIME X HERE WILL

INPUT YOUR DATA

} Time required to register your station

CU BI HW +?

OK TKS BI BI

## Transmitting message directly (DIRTLX)

The procedure which follows shows how to transmit a Telex message directly to a station.

1. Execute "Calling a Station" on page 5-3.
2. After GA+ and DIRTLX appear on your display, type Receiving station's Telex number.
3. Singapore coast station sends its Telex number. Type receiving station's answerback code.
4. Type MSG+?
5. Type your message.
6. Type WRU. Receiving station and your station mutually exchange answerback codes automatically.
7. Type KKKK (end code) at end of message. Your answerback code, receiving station's Telex number and communication time appear on your display.
8. Receiving station sends GA+?.

To send another message by DIRTLX, start at step 2. To finish, type BRK+

9VG SERADIO RS 55908 UGOX X	Exchange answerback codes
GA +?	After GA+ appears type Receiving station's Telex number.
DIRTLX07205644325 = +	
TRY AGAIN OR USE 'OPR'	If there is a mistake in the number coast station asks you to reenter number.
GA +?	
DIRTLEX07205644325 +	Receiving station's Telex no.
MOM07205644325 +	Type receiving station's answerback code.
5644325FURUNO J	
MSG +?	Prepare to send message.
{ 12345 FURUNO J	
TO FURUNO	
THIS IS A TEST MESSAGE FROM ab cdefgh ijkl IN KOBE.	Type message.
WRU	
5644325FURUNO J +?	
54321 ABCD N	
KKKK	End code. Your ship's answerback code, receiving station's Telex no. and communication time appear.
55908 UGOX X	
9VG SERADIO RS	
TIME: 29. 5. 96 7:49	
SHIP: 555908 UGOX X	
SUBSCR:07205644325 +	
DURATION:1.4MIN	
GA +?	
BRK +	BRK + disconnects the communication line. To send another message type DIRTLX instead of BRK +.

## Table of Abbreviations

Abbreviation	Question	Answer or Advice
QRA	What is the name your station?	The name of my station is . . . . .
QRC	By what private enterprise are the accounts for charges for your station settled?	The accounts for my station are settled by the private enterprise . . . . .
QRU	Have you any thing for me?	I have nothing for you.
QRV	Are you ready?	I am ready.
QRX	When will you call me again?	I will call you again at . . . . hours [on . . . . kHz].
QSJ	What is the charge to be collected to . . . including your internal charge?	The charge to be collected to . . . including my internal charge is . . . . francs . . . . .
QSL	Can you acknowledge receipt?	I can acknowledge receipt.
QSX	Will you listen to . . . . [call sign] on . . . . kHz?	I am listening to . . . . [call sign] on . . . . kHz.
QTA	Shall I cancel message number . . . . ?	Cancel message number . . . .
QTC	How many messages have you to send?	I have . . . . message for you.
QTU	What are the hours your station is open?	My station is open from . . . . to . . . . hours.
Abbreviation	Definition	
BK	Signal used to interrupt a transmission progress.	
CFM	Confirm	
DE	"From . . . . "	
K	Invitation to transmit.	
NIL	I have nothing to send to you.	
NW	Now	
PSE	Please	
R	Received	
REF	Reference to . . . . .	
SVC	Prefix indicating a service telegram.	

## Command an Abbreviation

Command	Function
TGM+	To indicate that the following message is a radiotelegram.
MSG+	To indicate that the ship station needs to be connected immediately any message held.
OPR+	Call operator.
URG+	Safety, urgency and distress message.
MED+	Request medical advice.
TEST+	Request coast station to send a test message for checking the ship station.
BRK+	To clear the connection with the coast station.
Abbreviation	
GA+	I am ready. Transmit your command.
MOM	Wait a moment.
MSG+	Request pending messages from the shore.
KKKK or NNNN	Terminate a message.



## 5.8 Timer Operation

A built-in timer permits automatic transmission and reception of telex messages.

### Enabling Timer Operation

1. Press function key [F3] to display the Operate menu.
2. Press the [7] key to display the Timer Operation List.
3. Select the operation (name) you wish to execute. Press the [Enter] key. An asterisk appears beside the operation selected and "T. Op" appears in inverse video on the communication status display. If a file from a floppy disk is to be sent, be sure the floppy disk containing the file is inserted in the drive.

```
Timer Operation List
*1
2
3
OP4
OP5
```

Figure 5-10 Timer operation list

4. Select another operation (name) if desired.
5. Press the [Esc] key.

When the predetermined time comes, the DP-6 automatically sends or receives messages. The results of timer operation are displayed as either OK or NG (No Good) on the Timer Operation List.

```
Timer Operation List
*1 OK
2
*3 OK
*OP4 OK
*OP5 NG
```

Figure 5-11 Timer operation list

### Stopping Timer Operation

1. Press function key [F3].
2. Press the [7] key.
3. Select the operation (name) which has asterisk attached to it and then press the [Enter] key. Remove all asterisks to cancel all timer programs.

## 5.9 Scanning

Radio equipment scans a group of operator-selected frequencies (channels), and stops scanning when an incoming signal is received.

1. Press function key [F3] and then the [5] key. The Scanning Group List appears on the screen.

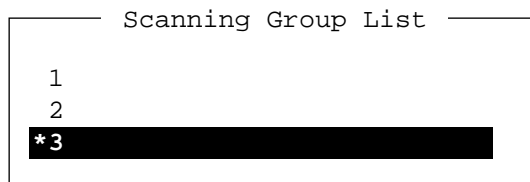

Figure 5-12 Scanning group list

2. Select a scan group and press the [Enter] key.
3. The scanning starts and the indication "Scan" appears in inverse video on the communication status display. (The name of the scan group appears at the "Station Name".)

```
1:File 2:Edit 3:Operate 4:Window 5:Station 6:System 7:WRU 8:HR 9:Over 10:Break
-----1996-11-15 02:01 (JST)-----
Station Name      : SAITO-1          Print Scan T.Op HT
Frequency (T/R)  : 8344.00 / 8705.00(kHz)  Comm Mode : CW
Comm Status      : Connect Send Lock Error
Sending Volume   : 100(%)   ARQ Error : 0   ARQ Time : 0(sec)
-----
```

Figure 5-13 Communication status display

4. To stop scanning, press function key [F3] and then the [5] key.

## 5.10 Communication Buffer

The communication buffer is a temporal memory which stores transmitting messages or receiving messages. To display the contents of the communication buffer;

1. Escape from the communication display.
2. Press the [PgDn] or [PgUp] key. The contents of the communication buffer are displayed.

To print them, press [Ctrl] and [P] keys simultaneously. To erase them from the screen, press [PgDn] key again.

# 6. WINDOW MENU

The Window menu allows you to display one of the following together with the current screen:

- 1) Navigation data
- 2) Calendar
- 3) Remote controller screen (Remote A or Remote B)
- 4) Distress frequencies

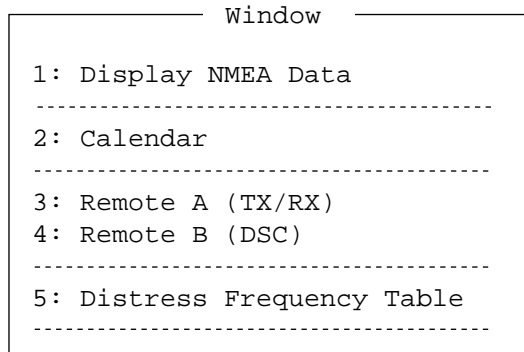

Figure 6-1 Window menu

## 6.1 Window Menu Description

### Display NMEA Data

With connection of a navaid and appropriate sensors which output nav data in IEC1162 (NMEA0183) format, position, speed, water temperature, depth and heading can be displayed. Press function key [F4] and the [1] key. Asterisks appear where there is no data.

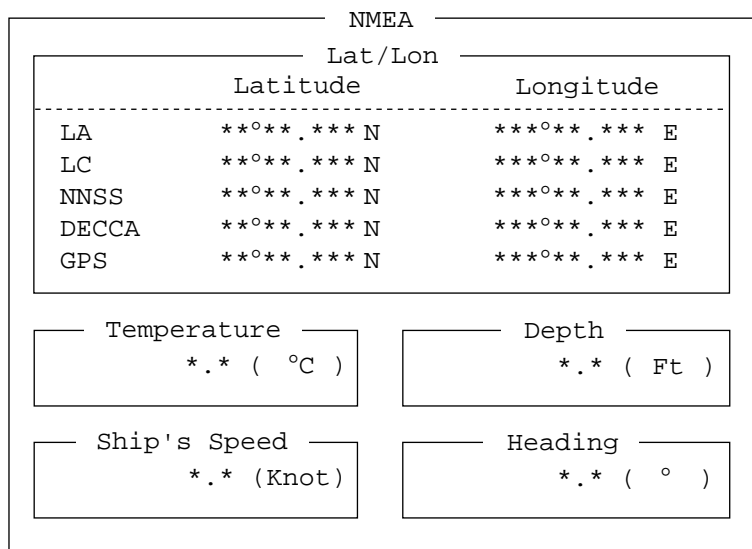

Figure 6-2 NMEA data display

## Calendar

The Calendar menu displays the calendar of any combination of month and year you desire. Press function key [F4] and the [2] key. To change year or month, select it by the [↑]/[↓] keys and change by the [←]/[→] keys.

Calendar						
Year :	1996					
Month :	11					
Sun	Mon	Tue	Wed	Thu	Fri	Sat
( 3)	4	5	6	7	1 8	2 9
(10)	11	12	13	14	15	16
(17)	18	19	20	21	22	23
(24)	25	26	27	28	29	30

Figure 6-3 Calendar

## Remote A, Remote B

This menu permits remote control of a FURUNO transceiver, receiver or transmitter connected to Remote A or Remote B terminal. Press function key [F4] and the [3] key (Remote A) or the [4] key (Remote B).

Remote
MIF>

Figure 6-4 Remote screen

## Distress Frequency Table

This menu displays all current distress frequencies. Press function key [F4] and the [5] key.

Distress Frequencies						
Telephone (kHz) :	2182.0	4125.0	6215.0	8291.0	12290.0	16420.0
-----						
NBDP (kHz) :	2174.5	4177.5	6268.0	8376.5	12520.0	16695.0
-----						
DSC (kHz) :	2187.5	4207.5	6312.0	8414.5	12577.0	16804.5

Figure 6-5 Distress frequency table

# 7. MARITEX OPERATION

This chapter provides an overview to the MARITEX system. For detailed information, consult your MARITEX Traffic Manual.

## 7.1 What is MARITEX?

MARITEX, an acronym meaning MARitime TELeX, is a worldwide, round-the-clock, fully automatic and computerized network for maritime radiotelex. The MARITEX system is operated jointly by the Telecom Administrations of Denmark, Finland, Iceland, Norway, and Sweden. The system consists of the Central Computer System in Gothenburg, Sweden, run with two high technology computers, and sub-stations in Scandinavia, Panama, Manila, and Argentina. The Central System does all the message switching and co-ordinates the sub-station resources.

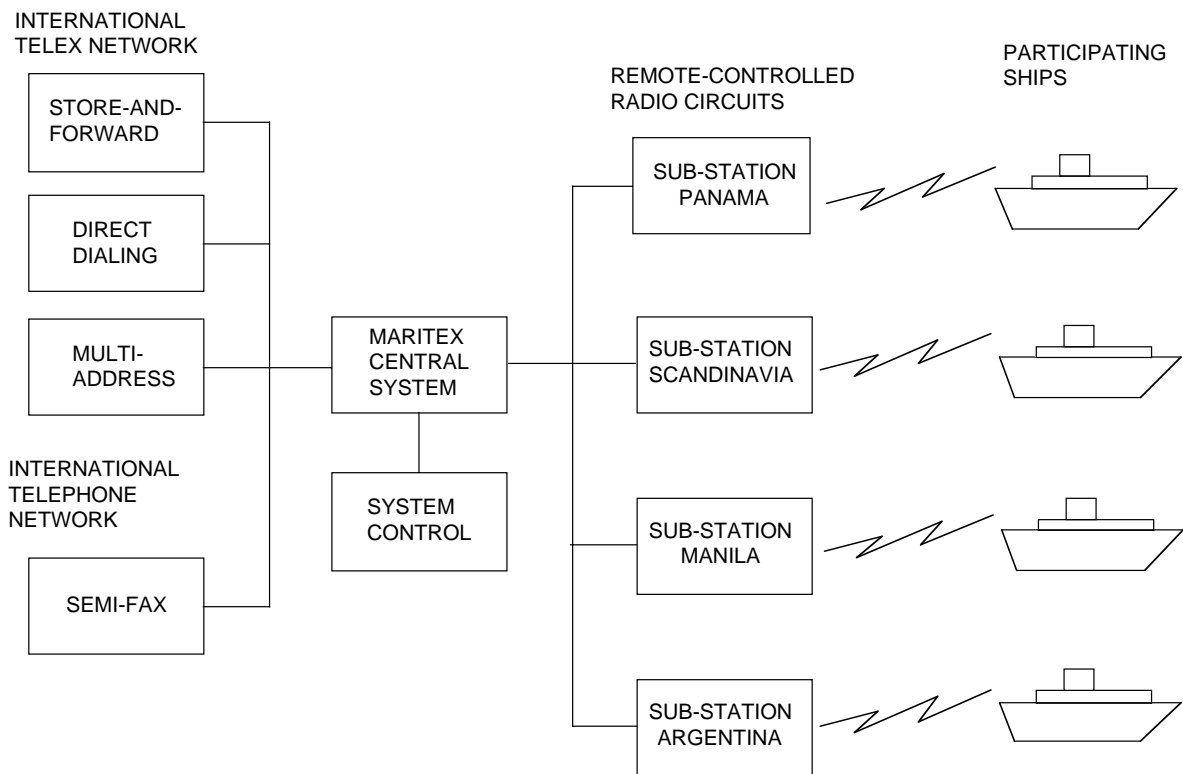

Figure 7-1 MARITEX system and services

## MARITEX Services

MARITEX provides four main services to MARITEX subscribers:

- Store-and-forward telex
- Direct dialing
- Multi address
- Semi-fax

**Note:** *MARITEX provides both shore-to-ship and ship-to-shore services. This manual, however, describes only the ship-to-shore communication procedures.*

## 7.2 Preparations for Transmission

To transmit a message in the MARITEX system, you will need to register three items:

- Answerback code
- Scan groups
- Station names

### Registering Answerback Code

MARITEX assigns a Telex number to all MARITEX subscribers. This number functions as an answerback code. An answerback code contains the following:

OOOOO SHIP X
--------------

OOOOO: MARITEX-assigned five-digit Telex code

SHIP: Ship name

X: For shipboard station, normally X is entered.

The procedure for registering answerback code is the same as which appears on page 3-1. If an answerback code was registered before the commissioning of the MARITEX station a new answerback code must be entered. To enter new answerback code, contact FURUNO or authorized FURUNO agent or dealer.

## Registering Scan Groups

The Central System emits a free-signal to indicate a MARITEX radio channel is in idle condition and available for ship-to-shore calls. The free-signal is detected and recognized by the shipboard equipment as a permission to start the transmission. Then, the shipboard operator initiates a call.

You can scan search for the free-signal automatically by registering MARITEX radio channels in scan group(s). The procedure for registering scan groups for MARITEX use is the same as that which appears on page 3-7.

1. Press function key [F5] to display the Station menu.
2. Press the [3] key to select Scan Entry. The screen should look something like Figure 7-2.

The screenshot shows the 'Scan Entry' screen. At the top, it says 'Scan Entry'. Below that is a box labeled 'Scanning Group List' which is currently empty. To the right of this box is a button labeled 'Create' and 'Change'. Below the 'Scanning Group List' box is a section titled 'Scanning Set Up'. This section contains several settings: 'Group Name' (with a cursor), 'Ch Dwell Time' (4.5 sec (2.7-4.5 sec)), 'Mode' (AUTO ARQ FEC), and 'Auto Search' (OFF ON). Below these settings is a table with columns for 'No', 'Channel', 'Rx Freq', 'Tx Freq', and 'Pass/Scan'. The table has 6 rows, with the 'Pass/Scan' column containing the text 'Pass/Scan' and an underline. A cursor is positioned at the end of the 6th row.

No	Channel	Rx Freq	Tx Freq	Pass/Scan
1				<u>Pass/Scan</u>
2				<u>Pass/Scan</u>
3				<u>Pass/Scan</u>
4				<u>Pass/Scan</u>
5				<u>Pass/Scan</u>
▼ 6				<u>Pass/Scan</u>

Figure 7-2 Scan entry screen

3. If Create is not underlined, press [→], [↑] and the [Enter] key to underline it.
4. Group Name appears in inverse video, meaning you can enter scan group name. Enter scan group name; for example, MARITEX-A.
5. Press the [↓] key to advance the cursor to Ch Dwell Time. The dwell times is the time in seconds the receiver waits on each channel before it selects the next channel. The default setting is 2.7 seconds. Change the setting if necessary.

6. Press the [↓] key to advance the cursor to Mode. Select the communication mode, AUTO, ARQ or FEC.
7. Press the [↓] key to advance the cursor to Auto Search. Turn Auto Search ON or OFF;

**Auto Search ON:** Radio stops scanning when it finds the strongest (S/N ratio) free-signal frequency. Use it where signal propagation is poor.

**Auto Search OFF:** Scanning starts and stops with the first-received free-signal frequency. Normally, use this position.

8. Press [↓] to place the cursor on the No. 1 line. Enter channel or user channel. See the table on the next page for MARITEX radio channel information. Then, press the [→] key to select "Scan".
9. Press [↓] to advance the cursor to the No. 2 line. Enter channel number. Repeat this procedure for other channels, up to 20.
10. Press the [Enter] key.
11. Press the [Enter] key again to register scan group.

Scan Entry

Scanning Group List

MARITEX-A

Create  
Change

---

Scanning Set Up

**Group Name** : MARITEX-A

Ch Dwell Time : 4.5 sec (2.7-4.5 sec)

Mode : AUTO ARQ FEC

Auto Search : OFF ON

---

No	Channel	Rx Freq	Tx Freq	Pass/Scan
1	1	4268.60	4203.50	Pass/ <u>Scan</u>
2	2	6460.00	6302.00	Pass/ <u>Scan</u>
3	3	8556.00	8398.50	Pass/ <u>Scan</u>
4	4	12818.00	12563.50	Pass/ <u>Scan</u>
5	5	17024.00	16790.50	Pass/ <u>Scan</u>
▼ 6	6	22607.00	22352.00	Pass/ <u>Scan</u>

*Figure 7-3 Scan entry screen*

To enter another scan group, select Create and then press the [Enter] key. Repeat steps 3 – 9.



*Table 7-1 MARITEX Channel*

ITU Channel	MARITEX No.	Coast Station TX (kHz)	Ship Station Tx (kHz)	Location
UP	A7	2423.5	3267.5	SWEDEN
UP	B7	2716.0	2477.0	SWEDEN
UP	D7	1905.0	2222.0	SWEDEN
UP	A1	4268.6	4203.5	SWEDEN
4009	B1	4214.5	4176.5	SWEDEN
4014	C1	4216.5	4179.0	SWEDEN
UP	A2	6460.0	6302.0	SWEDEN
6001	B2	6314.5	6263.0	SWEDEN
6019	C2	6323.0	6272.0	SWEDEN
UP	A3	8556.0	8398.5	SWEDEN
8007	B3	8419.5	8379.5	SWEDEN
8024	C3	8428.0	8388.0	SWEDEN
UP	A4	12818.0	12563.5	SWEDEN
12006	B4	12582.0	12479.5	SWEDEN
12024	C4	12591.0	12488.5	SWEDEN
UP	A5	17024.0	16790.5	SWEDEN
16014	B5	16813.5	16690.0	SWEDEN
16064	C5	16838.0	16715.0	SWEDEN
16057	C7	16834.5	16711.5	SWEDEN
UP	A6	22607.3	22352.0	SWEDEN
22007	B6	22379.5	22287.5	SWEDEN
22032	C6	22392.0	22300.0	SWEDEN
8017	D3	8424.5	8384.5	PANAMA
12008	D4	12583.0	12480.5	PANAMA
16033	D5	16822.5	16699.5	PANAMA
22031	D6	22391.5	22299.5	PANAMA
4006	F1	4213.0	4175.0	ARGENTINA
8040	F3	8436.0	8396.0	ARGENTINA
12050	F4	12604.0	12501.5	ARGENTINA
16188	F5	16900.0	16782.0	ARGENTINA
22040	F6	22396.0	22304.0	ARGENTINA
16164	F7	16888.0	16770.0	ARGENTINA
6001	G3	6314.5	6263.0	SAN FRANCISCO
8028	G4	8430.0	8390.0	SAN FRANCISCO
12028	G5	12593.0	12490.5	SAN FRANCISCO
16028	G6	16820.0	16697.0	SAN FRANCISCO
8027	G1	8429.5	8389.5	NEW ORLEANS
12067	G2	12612.5	12510.0	NEW ORLEANS
4019		4219.0	4181.5	CHINA/GUANGZHOU
6031		6329.0	6283.0	CHINA/GUANGZHOU
8030		8431.0	8391.0	CHINA/GUANGZHOU
12088		12622.5	12520.5	CHINA/GUANGZHOU
16096		16854.0	16731.0	CHINA/GUANGZHOU

Valid on 1997.

UP means no ITU channel assigned. You can use register these as user channels.

## Registering Stations

The next step is to enter station name. The procedure is the same as the procedure shown on page 3-3. The station list provides abbreviated dialing with storage for up to 50 stations.

1. Press function key [F5] and the [1] key. The Station Entry screen appears.

```
Station Entry
-----
Station List
-----
Create
Change

Station Set Up
-----
Station : █
ID Code :
Mode    : ARQ FEC DIRC
CH/Table : Channel ScanTable
Num/Table:
```

*Figure 7-4 Station entry screen*

2. If Create is not underlined, press [→], [↑] and the [Enter] key to underline it.
3. The cursor is on the Station line. Enter station name, using up to 20 characters.
4. Press the [↓] key to go to the ID Code line. Enter station ID code; the coast station selective call number common to all stations is 2950.
5. Press the [↓] key to go to the Mode line. The MARITEX system uses the ARQ mode.
6. Select ScanTable on the CH/Table line.
7. Press [↓] to go to Num/Table.

8. Press the [→] key to display the Scanning Group List.

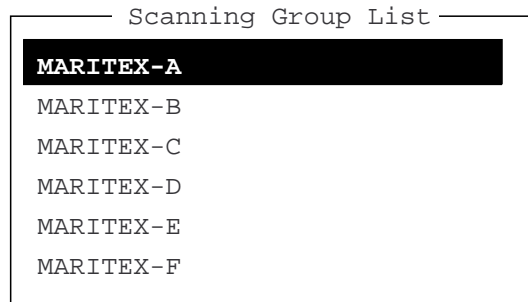

*Figure 7-5 Scanning group list (example)*

9. Select scan group.

10. Press the [Enter] key. To enter another station name, repeat the above procedure from step 2.

**Note:** *To establish the connection with a MARITEX station, the receiving frequencies in the scan group registered are scanned to detect a free signal from the station. If the free signal is detected, a message will be automatically transmitted to the station.*

## 7.3 Preparing Programs for Automatic Message Transmission

This section shows you how to prepare the programs necessary for automatic message transmission. The programs, which you can save to a floppy disk for future use, enable unattended automatic transmission.

The program for automatic transmission is called a macrofile. You will need several types of macrofiles depending on the MARITEX service to be utilized.

### Commands

The tables which follow describe the commands for automatic transmission.

Table 7-2 describes the commands processed by the DP-6.

Table 7-2 Commands processed by the DP-6

Command (prefixed with @)	Parameter	Content
CALL	S: Station Name I: ID	Calling station name and ID on assigned parameter
FREE (support command for CALL)	Two digits 0?99 min.	Free-signal searching time according to assigned parameter (default setting: 10 min.)
RETRY (support command for CALL)	Two digits 0?99 min.	Calling according to assigned parameter (default setting: 10 min.)
CASE	Text	For receiving a message (designated by parameter) transmitted by coast station
TIMEOUT (support command for CASE)	Two digits 0?99 min.	Time allotted for reception of message by CASE command
SEND	Text	Text transmitted according to assigned parameters
	B:file name	Send a file from floppy disk
WRU HR OVER BREAK	None	Function keys [F7] ? [F10]
DISPLAY	Text	Text of message appears
INPUT	None	Waiting for keyboard input Transmit keyboard input message

After reception of GA+?, enter appropriate short-code command. Table 7-3 shows the commands processed by MARITEX stations.

Table 7-3 MARITEX short-code commands

Command	Use
TLX ..... +	Store-and-forward Telex
DIRTLX ..... +	Direct dialing Telex
MULTI ..... +	Multi-address
FAX ..... +	Semi-fax
MSG+	Request pending messages from shore
NNNN+	Terminate message
BRK+	Clear the radio circuit

Other MARITEX short-code commands are as below.

Table 7-4 Other MARITEX short-code commands

Command	Use
POS+	Transmission of ship position reports
URG+	Safety, urgency and distress messages
MED+	Request medical advice
LTR+	For MARITEX letters mailed from the Operations Center to destinations worldwide
TST+	Request to MARITEX to send a test message consisting of all Telex characters
MRK+	Request to MARITEX to send a continuous mark tone for one minute

**Note:** For other supporting and facility commands, consult the *MARITEX Traffic Manual*.

## Store-and-Forward Telex

The following is the sequence of events in transmission of Telex message in MARITEX.

1. Shipboard station sends message to MARITEX coast station.
2. MARITEX coast station stores message in memory buffer.
3. Shipboard station and MARITEX coast station clear the radio circuit.
4. MARITEX station sends message to subscriber designated.

<u>No.</u>	<u>Procedure</u>	<u>Display</u>	<u>Remarks</u>
1	Call MARITEX.	CONNECT appears in inverse video (and bell sounds).	Free-signal found; radio circuit ready.
2	Transmit WRU signal.	MARITEX X 26 X X X SHIP X GA+?	Initial identity exchange between coast station and shipboard station
3	Key in subscriber's Telex number. Example: (Hong Kong) 12345		
	TLX80212345+	MSG+?	Request to start message transmission
4	Transmit file.		Message transmission
5	When transmission is completed, type NNNN.	26 X X X SHIP X MARITEX S DURATION DATE GA+?	Transmit your answerback code. Receive MARITEX station's answerback code. Tx time and date appear on DP-6.
6	Transmit BREAK command to clear radio circuit.		

## Preparing a macrofile for store-and-forward Telex

You will need a macrofile to enable automatic message transmission on store-and-forward Telex. After preparing it, save it to the hard disk or a floppy disk for future use.

1. Press function key [F1] to display the File menu.
2. Press the [1] key.
3. Prepare macrofile.

The figure below shows the minimum information required to send a store-and-forward Telex message in MARITEX.

```
< [1] UNTITLED1 >
@FREE 10 ----- ①
@CALL S: MARITEX ----- ②
@WRU
@CASE GA+?
@SEND TLX80212345+ ----- ③
@CASE MSG+?
@SEND B:ABC ----- ④
@SEND NNNN ----- ⑤
@CASE GA+?
@SEND BRK+
```

- ① Free-signal search time (10 minutes)
- ② Station name (Example: MARITEX)  
Who are you?  
Station identity exchange
- ③ Subscriber's Telex number (in example, 802 is country code of Hong Kong) for store-and-forward Telex
- ④ Location and name of file message
- ⑤ Request for termination of message

*Figure 7-6 Example macrofile for store-and-forward Telex*

4. Press function key [F1] to display the File menu.

5. Press the [5] key. The Save prompt appears on the display.

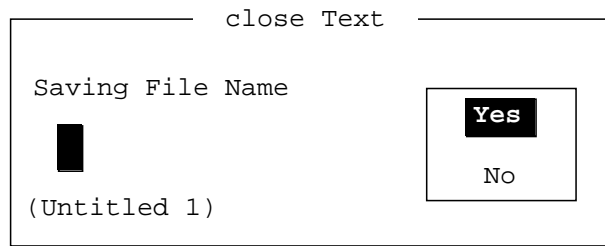

*Figure 7-7 Save prompt*

6. Press the [Enter] key and enter a file name as follows.

OOOOOOOO.MCR  
↑            ↑  
File Name    Extension Name  
(max. 8 characters)

7. Press the [Enter] key.



## Macrofile for Direct Dialing

The direct dialing features allows you to contact a land subscriber via MARITEX. Below is an example of a macrofile for direct dialing

@FREE 15	-----	①
@CALL S: MARITEX	-----	②
@WRU		
@CASE GA+?		
@SEND DIRTLX725644325+	-----	③
@CASE MSG+?		
@SEND B:ABC	-----	④
@SEND NNNN	-----	⑤
@CASE GA+?		
@SEND BRK+		

- ① Free-signal search time (15 minutes)
- ② Station name (Example: MARITEX)  
Who are you?  
Station identity exchange
- ③ Subscriber's Telex number (in example, 72 is country code of JAPAN) for direct dialing mode
- ④ Location and name of file message
- ⑤ Request for termination of message

*Figure 7-8 Example macrofile for direct dialing*

## Procedure for direct dialing

<u>No.</u>	<u>Procedure</u>	<u>Display</u>	<u>Remarks</u>
1	Call MARITEX.	CONNECT appears in inverse video (and bell sounds).	Free-signal found; radio circuit ready.
2	Transmit WRU signal.	MARITEX X 26 X X X SHIP X GA+?	Initial identity exchange between coast station and shipboard station
3	Key in subscriber's Telex number. Example: (Japan) 725644325	DIRTLX725644325+	12:20 MOM 5644325 FURUNO J MSG+?
4	Transmit prepared file or input message manually through keyboard.		Request to start message transmission
5	When transmission is completed, type NNNN.	26 X X X SHIP X 5644325 FURUNO J DURATION DATE GA+?	Message transmission
6	Transmit BREAK command to clear radio circuit.		Transmit your answerback code. Receive MARITEX station's answerback code. Tx time and date appear on DP-6.

## Macrofile for Multi Address

The figure which follows shows an example of a macrofile for multi address use.

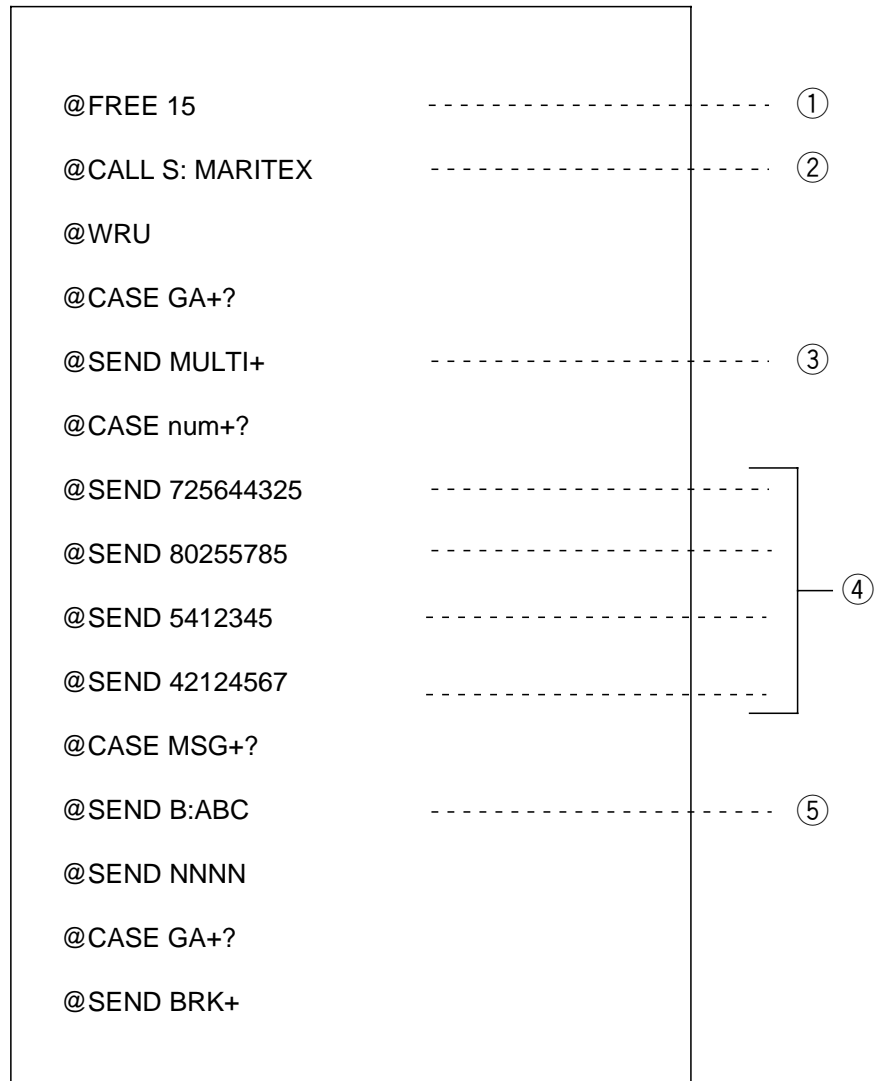

*Figure 7-9 Example of macrofile for use in multi address*

## Macrofile for Semi-fax

In the Semi-fax option, MARITEX converts ship-to-shore direction telex message to facsimile and retransmits it via the telephone network.

The figure below shows an example of a macrofile for Semi-fax. The macrofile for Semi-fax is the same as the macrofile for store-and-forward and direct dialing except for the FAX command.



*Figure 7-10 Example of macrofile for semi-fax*

## 7.4 Transmitting in MARITEX System

This section describes how to transmit a Telex message in MARITEX.

### Basic Procedure

1. Register answerback code (Telex number assigned by MARITEX).
2. Register MARITEX frequency and channel to scan group.
3. Register station name including scan group name.
4. Retrieve appropriate macrofile. Include station name and message file name. Type message and save file to memory.
5. Open macro operation menu and select macrofile. (See next page for details.) Your message will be transmitted automatically. Below is the sequence of automatic message transmission in MARITEX.
  - 1) Search for free-signal
  - 2) Call MARITEX station on MARITEX radio channel.
  - 3) After connection is established, identity exchange
  - 4) Transmission of service category and subscriber's address
  - 5) Transmission of message
  - 6) Transmission of termination of message signal
  - 7) Identity exchange
  - 8) Clearing of radio circuit

## Actual Transmission

1. Press function key [F3] to display the Operate menu.

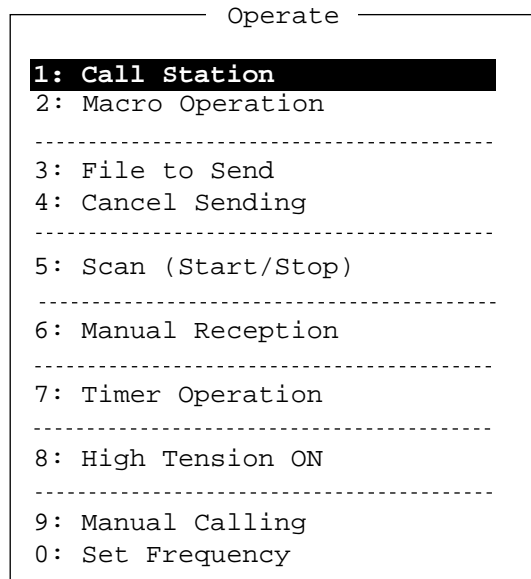

*Figure 7-11 Operate menu*

2. Press the [2] key. The Call Macro screen appears.

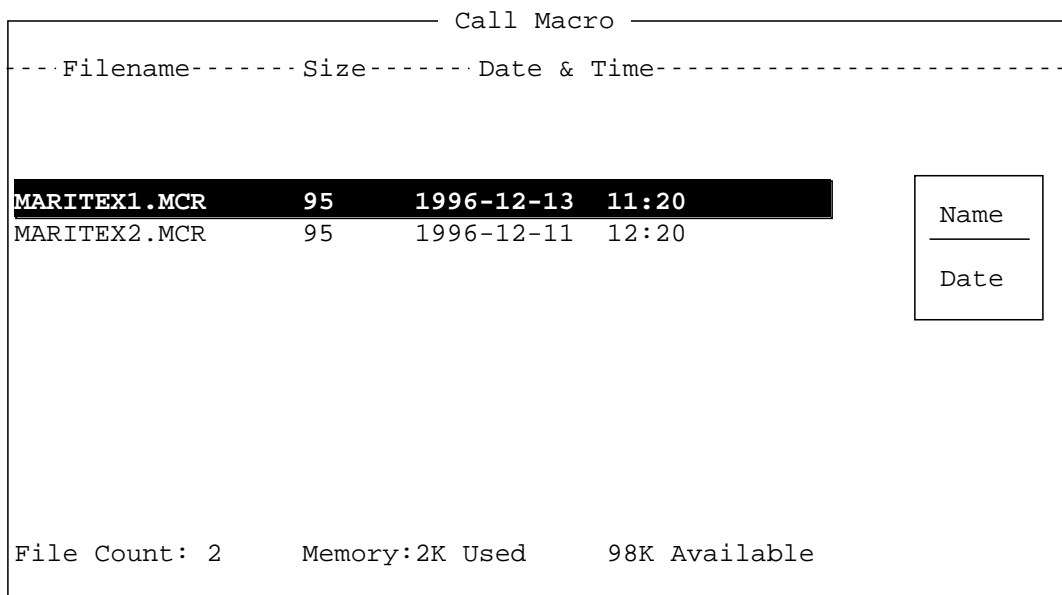
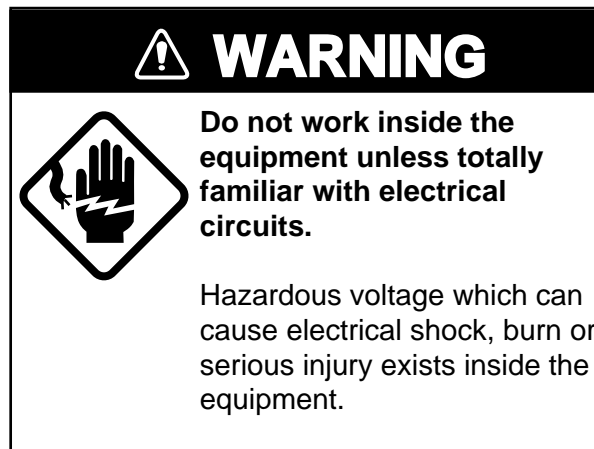

*Figure 7-12 Call macro screen*

3. Select desired macrofile and press the [Enter] key.
4. Press the [Enter] key to confirm the macrofile selected. The Wait for Free Signal indication appears. Your message will be transmitted automatically.

# 8. MAINTENANCE AND TROUBLESHOOTING

---



## 8.1 Maintenance

Regular maintenance is important for good performance. A regular maintenance program should be established and should at least include the following:

### Cleaning the Equipment

Wipe of accumulated dust from the equipment with a soft cloth. An anti-static cleaner may be used to clean the screen of the terminal unit. Do not use commercial cleaners to clean the equipment. They can remove paint and markings.

### Connectors and Earth Connection

Periodically check the connectors for proper seating and the earth connection for rust. Remove rust to maintain a good ground system.

### Floppy Disk Drive

Clean the floppy disk drive head regularly to prevent erasure of information stored on disks.

## 8.2 Simple Troubleshooting

### Power Supply

If the power cannot be applied (power lamp on the main unit does not light):

- Check for loosened power cable connector on the rear or bottom of units. Check that the ship's mains main switch is turned on. Confirm that power is present at the connector (pin #1:(+), pin #2: (-)).

Unit	Input Voltage
Main unit	18 to 36 VDC
Terminal unit	24 VDC

- Check if the breaker on the rear panel of the terminal unit has tripped. If it has tripped, push it in to reset the equipment.

## 8.3 Diagnostic Tests

### Self Test

1. Press function key [F6] to display the System menu.

System		Change	Default
Setup	Lock		
Slave Delay	5 msec	(0- 50 msec)	
BK Timing PreTone	10 msec	(0-100 msec)	
PostTone	0 msec	(0- 20 msec)	
Mute Timing PreBK	0 msec	(0- 20 msec)	
PostBK	0 msec	(0- 20 msec)	
Modem Output Level	0 dBm	(-30 - +10 dBm)	
MIF Tune	<u>OFF</u>	<u>O</u> N	
Freeze	<u>OFF</u>	<u>O</u> N	
AGC	<u>OFF</u>	<u>O</u> N	
Emission	<u>OFF</u>	<u>O</u> <u>N</u>	
TX/RX MSG Save	<u>OFF</u>	<u>O</u> N	
Edit Before sending	<u>OFF</u>	<u>O</u> N	
Time System	OFF	<u>UTC</u> SMT JST	
Time & Date	1997/1/1/12:34:56		
Display Mode	<u>Normal</u> Reverse		
Self Test			

Figure 8-1 System menu

2. Select Change on the Setup line.
3. Select Self Test.



4. Press the [Enter] key. The results of the self test are displayed a short time later.

```

----- Self Test -----
Terminal Unit Test : ver. 1.xx*1      :OK
Main Unit Test     : ver. 1.xx*1      :OK
Modem Unit Test    : ver. 1.xx*1      :OK
Radio Unit Test    : ID xxxx*2       :OK
DSC Unit Test      : ID xxxx*2       :OK
Printer Unit Test*3: Printer not Ready :NG

```

\*1: Current version no.

\*2: Actual ID numbers appears.

\*3: OK replaces NG when printer is turned on and

*Figure 8-2 Self test results*

If NG appears for any unit checked, try the self test again. If it appears again, call for service.

## Tone Test

1. Select Self Test on the System menu.
2. While pressing and holding down the [Shift] key, press the [↓] key.

```

----- Tone Test -----
1: Tone Test 1 (All Char)
2: Tone Test 2 (Fox)
3: Tone Test 3 (Beta)
-----
4: Tone Test 4 (Mark)
5: Tone Test 5 (Space)
6: Tone Test 6 (BY)

```

*Figure 8-3 Tone test*

3. Select test and press the [Enter] key. You may stop a test at anytime by pressing the [Enter] key.

### Tone test 1 (All characters)

This test (continuously) checks for proper transmission of all figures, letters and codes. To conduct the test, call a station in the ARQ or FEC modes. Execute the test, confirming that all characters are transmitted correctly. "Now testing Tone Test 1" appears during the testing. Since the test is conducted continuously, you may press [Esc] twice and [F10] key to stop the test and return to the tone test menu.

```

1:File 2:Edit 3:Operate 4:Window 5:Station 6:System 7:WRU 8:HR 9:Over 10:Break
-----
                                System
Station Name      :          Setup          Lock  Change  Default
Frequency (T/R)  :          /
Comm Status      :  Connect Sen
-----

```

```

Now Testing Tone Test 1 (All Char).

```

```

ABCDEFGHIJKLMNOPQRSTUVWXYZ1234567890-?:()., '=/+abcdefghijklmnopqrstuv
wxyz

```

```

ABCDEFGHIJKLMNOPQRSTUVWXYZ1234567890-?:()., '=/+abcdefghijklmnopqrstuv
wxyz

```

```

ABCDEFGHIJKLMNOPQRSTUVWXYZ

```

*Figure 8-4 All characters test screen*

**Tone test 2 (Fox)**

This test (continuously) checks for proper transmission of the test message THE QUICK BROWN FOX JUMPS OVER THE LAZY DOG 0123456789. In order to conduct the test call a station over the ARQ or FEC mode.

**Tone test 3 (Beta)**

You may check for proper transmission of the idle signal β. Call up a station using the ARQ mode.

**Tone test 4 (Mark)**

This test outputs the mark signal through the LINE OUT terminal, where a frequency counter may be connected, to confirm its frequency (1615 Hz).

**Tone test 5 (Space)**

Tone test 5 verifies the space signal frequency (1785 Hz).

**Tone test 6 (BY)**

This test verifies the frequency of the space B (1785 Hz) and mark Y (1615 Hz), using a spectrum analyzer.

# APPENDIX 1 ITU TELEX CHANNELS/ FREQUENCY LIST

ITU TELEX FREQUENCY TABLE (1/4)

**FURUNO**

4 MHz BAND			6 MHz BAND			8 MHz BAND			12 MHz BAND			16 MHz BAND			18/19 MHz BAND			22 MHz BAND			25/26 MHz BAND		
No.	TX	RX	No.	TX	RX	No.	TX	RX	No.	TX	RX	No.	TX	RX	No.	TX	RX	No.	TX	RX	No.	TX	RX
4001	4172.5	4210.5	6001	6263.0	6314.5	8001	8376.5	8417.0	12001	12477.0	12579.5	16001	16683.5	16807.0	18001	18870.5	19681.0	22001	22284.5	22376.5	25001	25173.0	26101.0
4002	4173.0	4211.0	6002	6263.5	6315.0	8002	8377.0	8417.5	12002	12477.5	12580.0	16002	16684.0	16808.0	18002	18871.0	19681.5	22002	22285.0	22377.0	25002	25173.5	26101.5
4003	4173.5	4211.5	6003	6264.0	6315.5	8003	8377.5	8418.0	12003	12478.0	12580.5	16003	16684.5	16808.5	18003	18871.5	19682.0	22003	22285.5	22377.5	25003	25174.0	26102.0
4004	4174.0	4212.0	6004	6264.5	6316.0	8004	8378.0	8418.5	12004	12478.5	12581.0	16004	16685.0	16809.0	18004	18872.0	19682.5	22004	22286.0	22378.0	25004	25174.5	26102.5
4005	4174.5	4212.5	6005	6265.0	6316.5	8005	8378.5	8419.0	12005	12479.0	12581.5	16005	16685.5	16809.5	18005	18872.5	19683.0	22005	22286.5	22378.5	25005	25175.0	26103.0
4006	4175.0	4213.0	6006	6265.5	6317.0	8006	8379.0	8419.5	12006	12479.5	12582.0	16006	16686.0	16809.5	18006	18873.0	19683.5	22006	22287.0	22379.0	25006	25175.5	26103.5
4007	4175.5	4213.5	6007	6266.0	6317.5	8007	8379.5	8420.0	12007	12480.0	12582.5	16007	16686.5	16810.0	18007	18873.5	19684.0	22007	22287.5	22379.5	25007	25176.0	26104.0
4008	4176.0	4214.0	6008	6266.5	6318.0	8008	8380.0	8420.5	12008	12480.5	12583.0	16008	16687.0	16810.5	18008	18874.0	19684.5	22008	22288.0	22380.0	25008	25176.5	26104.5
4009	4176.5	4214.5	6009	6267.0	6318.5	8009	8380.5	8421.0	12009	12481.0	12583.5	16009	16687.5	16811.0	18009	18874.5	19685.0	22009	22288.5	22380.5	25009	25177.0	26105.0
4010	4177.0	4215.0	6010	6267.5	6319.0	8010	8381.0	8421.5	12010	12481.5	12584.0	16010	16688.0	16811.5	18010	18875.0	19685.5	22010	22289.0	22381.0	25010	25177.5	26105.5
4011	4177.5	4215.5	6011	6268.0	6319.5	8011	8381.5	8422.0	12011	12482.0	12584.5	16011	16688.5	16812.0	18011	18875.5	19686.0	22011	22289.5	22381.5	25011	25178.0	26106.0
4012	4178.0	4216.0	6012	6268.5	6320.0	8012	8382.0	8422.5	12012	12482.5	12585.0	16012	16689.0	16812.5	18012	18876.0	19686.5	22012	22290.0	22382.0	25012	25178.5	26106.5
4013	4178.5	4216.5	6013	6269.0	6320.5	8013	8382.5	8423.0	12013	12483.0	12585.5	16013	16689.5	16813.0	18013	18876.5	19687.0	22013	22290.5	22382.5	25013	25179.0	26107.0
4014	4179.0	4217.0	6014	6269.5	6321.0	8014	8383.0	8423.5	12014	12483.5	12586.0	16014	16690.0	16813.5	18014	18877.0	19687.5	22014	22291.0	22383.0	25014	25179.5	26107.5
4015	4179.5	4217.5	6015	6270.0	6321.5	8015	8383.5	8424.0	12015	12484.0	12586.5	16015	16690.5	16814.0	18015	18877.5	19688.0	22015	22291.5	22383.5	25015	25180.0	26108.0
4016	4180.0	4218.0	6016	6270.5	6322.0	8016	8384.0	8424.5	12016	12484.5	12587.0	16016	16691.0	16814.5	18016	18878.0	19688.5	22016	22292.0	22384.0	25016	25180.5	26108.5
4017	4180.5	4218.5	6017	6271.0	6322.5	8017	8384.5	8425.0	12017	12485.0	12587.5	16017	16691.5	16815.0	18017	18878.5	19689.0	22017	22292.5	22384.5	25017	25181.0	26109.0
4018	4181.0	4219.0	6018	6271.5	6323.0	8018	8385.0	8425.5	12018	12485.5	12588.0	16018	16692.0	16815.5	18018	18879.0	19689.5	22018	22293.0	22385.0	25018	25181.5	26109.5
4019	4181.5	4219.5	6019	6272.0	6323.5	8019	8385.5	8426.0	12019	12486.0	12588.5	16019	16692.5	16816.0	18019	18879.5	19690.0	22019	22293.5	22385.5	25019	25182.0	26110.0
4020	4202.5	4203.5	6020	6272.5	6324.0	8020	8386.0	8426.5	12020	12486.5	12589.0	16020	16693.0	16816.5	18020	18880.0	19690.5	22020	22294.0	22386.0	25020	25182.5	26110.5
4021	4203.0	4204.0	6021	6273.0	6324.5	8021	8386.5	8427.0	12021	12487.0	12589.5	16021	16693.5	16817.0	18021	18880.5	19691.0	22021	22294.5	22386.5	25021	25183.0	26111.0
4022	4203.5	4204.5	6022	6273.5	6325.0	8022	8387.0	8427.5	12022	12487.5	12590.0	16022	16694.0	16817.5	18022	18881.0	19691.5	22022	22295.0	22387.0	25022	25183.5	26111.5
4023	4204.0	4205.0	6023	6274.0	6325.5	8023	8387.5	8428.0	12023	12488.0	12590.5	16023	16694.5	16818.0	18023	18881.5	19692.0	22023	22295.5	22387.5	25023	25184.0	26112.0
4024	4204.5	4205.5	6024	6274.5	6326.0	8024	8388.0	8428.5	12024	12488.5	12591.0	16024	16695.0	16818.5	18024	18882.0	19692.5	22024	22296.0	22388.0	25024	25184.5	26112.5
4025	4205.0	4206.0	6025	6275.0	6326.5	8025	8388.5	8429.0	12025	12489.0	12591.5	16025	16695.5	16819.0	18025	18882.5	19693.0	22025	22296.5	22388.5	25025	25185.0	26113.0
4026	4205.5	4206.5	6026	6275.5	6327.0	8026	8389.0	8429.5	12026	12489.5	12592.0	16026	16696.0	16819.5	18026	18883.0	19693.5	22026	22297.0	22389.0	25026	25185.5	26113.5
4027	4206.0	4207.0	6027	6281.0	6327.0	8027	8389.5	8429.5	12027	12490.0	12592.5	16027	16696.5	16819.5	18027	18883.5	19694.0	22027	22297.5	22389.5	25027	25186.0	26114.0
4028	4206.5	4207.5	6028	6281.5	6327.5	8028	8390.0	8430.0	12028	12490.5	12593.0	16028	16697.0	16820.0	18028	18884.0	19694.5	22028	22298.0	22390.0	25028	25186.5	26114.5
4029	4207.0	4208.0	6029	6282.0	6328.0	8029	8390.5	8430.5	12029	12491.0	12593.5	16029	16697.5	16820.5	18029	18884.5	19695.0	22029	22298.5	22390.5	25029	25187.0	26115.0
4030	4207.5	4208.5	6030	6282.5	6328.5	8030	8391.0	8431.0	12030	12491.5	12594.0	16030	16698.0	16821.0	18030	18885.0	19695.5	22030	22299.0	22391.0	25030	25187.5	26115.5
4031	4208.0	4209.0	6031	6283.0	6329.0	8031	8391.5	8431.5	12031	12492.0	12594.5	16031	16698.5	16821.5	18031	18885.5	19696.0	22031	22299.5	22391.5	25031	25188.0	26116.0
4032	4208.5	4209.5	6032	6283.5	6329.5	8032	8392.0	8432.0	12032	12492.5	12595.0	16032	16699.0	16822.0	18032	18886.0	19696.5	22032	22300.0	22392.0	25032	25188.5	26116.5
4033	4209.0	4210.0	6033	6284.0	6330.0	8033	8392.5	8432.5	12033	12493.0	12595.5	16033	16699.5	16822.5	18033	18886.5	19697.0	22033	22300.5	22392.5	25033	25189.0	26117.0
4034	4209.5	4210.5	6034	6284.5	6330.5	8034	8393.0	8433.0	12034	12493.5	12596.0	16034	16700.0	16823.0	18034	18887.0	19697.5	22034	22301.0	22393.0	25034	25189.5	26117.5
4035	4210.0	4211.0	6035	6285.0	6331.0	8035	8393.5	8433.5	12035	12494.0	12596.5	16035	16700.5	16823.5	18035	18887.5	19698.0	22035	22301.5	22393.5	25035	25190.0	26118.0
6036	6301.0	6301.5	8036	8394.0	8434.0	12036	12494.5	12597.0	16036	16701.0	16824.0	18036	18888.0	19698.5	22036	22302.0	22394.0	25036	22302.0	22394.0	25036	25190.5	26118.5
6037	6301.5	6302.0	8037	8394.5	8434.5	12037	12495.0	12597.5	16037	16701.5	16824.5	18037	18888.5	19699.0	22037	22302.5	22394.5	25037	22302.5	22394.5	25037	25191.0	26119.0
6038	6302.0	6302.5	8038	8395.0	8435.0	12038	12495.5	12598.0	16038	16702.0	16825.0	18038	18889.0	19699.5	22038	22303.0	22395.0	25038	22303.0	22395.0	25038	25191.5	26119.5
6039	6302.5	6303.0	8039	8395.5	8435.5	12039	12496.0	12598.5	16039	16702.5	16825.5	18039	18889.5	19700.0	22039	22303.5	22395.5	25039	22303.5	22395.5	25039	25192.0	26120.0
6040	6303.0	6303.5	8040	8396.0	8436.0	12040	12496.5	12599.0	16040	16703.0	16826.0	18040	18890.0	19700.5	22040	22304.0	22396.0	25040	22304.0	22396.0	25040	25192.5	26120.5
6041	6303.5	6304.0	8041	8396.5	8436.5	12041	12497.0	12599.5	16041	16703.5	16826.5	18041	18890.5	19701.0	22041	22304.5	22396.5	25041	22304.5	22396.5	25041	25193.0	26121.0
6042	6304.0	6304.5	8042	8397.0	8437.0	12042	12497.5	12600.0	16042	16704.0	16827.0	18042	18891.0	19701.5	22042	22305.0	22397.0	25042	22305.0	22397.0	25042	25193.5	26121.5
6043	6304.5	6305.0	8043	8397.5	8437.5	12043	12498.0	12600.5	16043	16704.5	16827.5	18043	18891.5	19702.0	22043	22305.5	22397.5	25043	22305.5	22397.5	25043	25194.0	26122.0
6044	6305.0	6305.5	8044	8398.0	8438.0	12044	12498.5	12601.0	16044	16705.0	16828.0	18044	18892.0	19702.5	22044	22306.0	22398.0	25044	22306.0	22398.0	25044	25194.5	26122.5
6045	6305.5	6306.0	8045	8398.5	8438.5																		

4 MHz BAND		6 MHz BAND		8 MHz BAND		12 MHz BAND		16 MHz BAND		18/19 MHz BAND		22 MHz BAND		25/26 MHz BAND			
No.	Tx	Rx	No.	Tx	Rx	No.	Tx	Rx	No.	Tx	Rx	No.	Tx	Rx	No.	Tx	Rx
8066		8409.0	12066	12509.5	12612.0	16066	16716.0	16839.0				22066	22317.0	22409.0	25066	25205.5	25206.5
8067		8409.5	12067	12510.0	12612.5	16067	16716.5	16839.5				22067	22317.5	22410.0	25067	25206.0	25206.5
8068		8410.0	12068	12510.5	12613.0	16068	16717.0	16840.0				22068	22318.0	22410.5	25068	25206.5	25207.0
8069		8410.5	12069	12511.0	12613.5	16069	16717.5	16840.5				22069	22318.5	22411.0	25069	25207.0	25207.5
8070		8411.0	12070	12511.5	12614.0	16070	16718.0	16841.0				22070	22319.0	22411.5	25070	25207.5	25208.0
8071		8411.5	12071	12512.0	12614.5	16071	16718.5	16841.5				22071	22319.5	22412.0	25071	25208.0	25208.5
8072		8412.0	12072	12512.5	12615.0	16072	16719.0	16842.0				22072	22320.0	22412.5	25072	25208.5	25209.0
8073		8412.5	12073	12513.0	12615.5	16073	16719.5	16842.5				22073	22320.5	22413.0	25073	25209.0	25209.5
8074		8413.0	12074	12513.5	12616.0	16074	16720.0	16843.0				22074	22321.0	22413.5	25074	25209.5	25210.0
8075		8413.5	12075	12514.0	12616.5	16075	16720.5	16843.5				22075	22321.5	22414.0			
8076		8414.0	12076	12514.5	12617.0	16076	16721.0	16844.0				22076	22322.0	22414.5			
8077		8414.5	12077	12515.0	12617.5	16077	16721.5	16844.5				22077	22322.5	22415.0			
8078		8415.0	12078	12515.5	12618.0	16078	16722.0	16845.0				22078	22323.0	22415.5			
8079		8415.5	12079	12516.0	12618.5	16079	16722.5	16845.5				22079	22323.5	22416.0			
8080		8416.0	12080	12516.5	12619.0	16080	16723.0	16846.0				22080	22324.0	22416.5			
			12081	12517.0	12619.5	16081	16723.5	16846.5				22081	22324.5	22417.0			
			12082	12517.5	12620.0	16082	16724.0	16847.0				22082	22325.0	22417.5			
			12083	12518.0	12620.5	16083	16724.5	16847.5				22083	22325.5	22418.0			
			12084	12518.5	12621.0	16084	16725.0	16848.0				22084	22326.0	22418.5			
			12085	12519.0	12621.5	16085	16725.5	16848.5				22085	22326.5	22419.0			
			12086	12519.5	12622.0	16086	16726.0	16849.0				22086	22327.0	22419.5			
			12087	12520.0	12622.5	16087	16726.5	16849.5				22087	22327.5	22420.0			
			12088	12520.5	12623.0	16088	16727.0	16850.0				22088	22328.0	22420.5			
			12089	12521.0	12623.5	16089	16727.5	16850.5				22089	22328.5	22421.0			
			12090	12521.5	12624.0	16090	16728.0	16851.0				22090	22329.0	22421.5			
			12091	12522.0	12624.5	16091	16728.5	16851.5				22091	22329.5	22422.0			
			12092	12522.5	12625.0	16092	16729.0	16852.0				22092	22330.0	22422.5			
			12093	12523.0	12625.5	16093	16729.5	16852.5				22093	22330.5	22423.0			
			12094	12523.5	12626.0	16094	16730.0	16853.0				22094	22331.0	22423.5			
			12095	12524.0	12626.5	16095	16730.5	16853.5				22095	22331.5	22424.0			
			12096	12524.5	12627.0	16096	16731.0	16854.0				22096	22332.0	22424.5			
			12097	12525.0	12627.5	16097	16731.5	16854.5				22097	22332.5	22425.0			
			12098	12525.5	12628.0	16098	16732.0	16855.0				22098	22333.0	22425.5			
			12099	12526.0	12628.5	16099	16732.5	16855.5				22099	22333.5	22426.0			
			12100	12526.5	12629.0	16100	16733.0	16856.0				22100	22334.0	22426.5			
			12101	12527.0	12629.5	16101	16733.5	16856.5				22101	22334.5	22427.0			
			12102	12527.5	12630.0	16102	16734.0	16857.0				22102	22335.0	22427.5			
			12103	12528.0	12630.5	16103	16734.5	16857.5				22103	22335.5	22428.0			
			12104	12528.5	12631.0	16104	16735.0	16858.0				22104	22336.0	22428.5			
			12105	12529.0	12631.5	16105	16735.5	16858.5				22105	22336.5	22429.0			
			12106	12529.5	12632.0	16106	16736.0	16859.0				22106	22337.0	22429.5			
			12107	12530.0	12632.5	16107	16736.5	16859.5				22107	22337.5	22430.0			
			12108	12530.5	12633.0	16108	16737.0	16860.0				22108	22338.0	22430.5			
			12109	12531.0	12633.5	16109	16737.5	16860.5				22109	22338.5	22431.0			
			12110	12531.5	12634.0	16110	16738.0	16861.0				22110	22339.0	22431.5			
			12111	12532.0	12634.5	16111	16738.5	16861.5				22111	22339.5	22432.0			
			12112	12532.5	12635.0	16112	16739.0	16862.0				22112	22340.0	22432.5			
			12113	12533.0	12635.5	16113	16739.5	16862.5				22113	22340.5	22433.0			
			12114	12533.5	12636.0	16114	16740.0	16863.0				22114	22341.0	22433.5			
			12115	12534.0	12636.5	16115	16740.5	16863.5				22115	22341.5	22434.0			
			12116	12534.5	12637.0	16116	16741.0	16864.0				22116	22342.0	22434.5			
			12117	12535.0	12637.5	16117	16741.5	16864.5				22117	22342.5	22435.0			
			12118	12535.5	12638.0	16118	16742.0	16865.0				22118	22343.0	22435.5			
			12119	12536.0	12638.5	16119	16742.5	16865.5				22119	22343.5	22436.0			
			12120	12536.5	12639.0	16120	16743.0	16866.0				22120	22344.0	22436.5			
			12121	12537.0	12639.5	16121	16743.5	16866.5				22121	22344.5	22437.0			
			12122	12537.5	12640.0	16122	16744.0	16867.0				22122	22345.0	22437.5			
			12123	12538.0	12640.5	16123	16744.5	16867.5				22123	22345.5	22438.0			
			12124	12538.5	12641.0	16124	16745.0	16868.0				22124	22346.0	22438.5			
			12125	12539.0	12641.5	16125	16745.5	16868.5				22125	22346.5	22439.0			
			12126	12539.5	12642.0	16126	16746.0	16869.0				22126	22347.0	22439.5			
			12127	12540.0	12642.5	16127	16746.5	16869.5				22127	22347.5	22440.0			
			12128	12540.5	12643.0	16128	16747.0	16870.0				22128	22348.0	22440.5			
			12129	12541.0	12643.5	16129	16747.5	16870.5				22129	22348.5	22441.0			
			12130	12541.5	12644.0	16130	16748.0	16871.0				22130	22349.0	22441.5			



4 MHz BAND		6 MHz BAND		8 MHz BAND		12 MHz BAND		16 MHz BAND		18/19 MHz BAND		22 MHz BAND		25/26 MHz BAND			
No.	TX	RX	No.	TX	RX	No.	TX	RX	No.	TX	RX	No.	TX	RX	No.	TX	RX
									16196	16786.0	16786.0						
									16197	16786.5	16786.5						
									16198	16787.0	16787.0						
									16199	16787.5	16787.5						
									16200	16788.0	16788.0						
									16201	16788.5	16788.5						
									16202	16789.0	16789.0						
									16203	16789.5	16789.5						
									16204	16790.0	16790.0						
									16205	16790.5	16790.5						
									16206	16791.0	16791.0						
									16207	16791.5	16791.5						
									16208	16792.0	16792.0						
									16209	16792.5	16792.5						
									16210	16793.0	16793.0						
									16211	16793.5	16793.5						
									16212	16794.0	16794.0						
									16213	16794.5	16794.5						
									16214	16795.0	16795.0						
									16215	16795.5	16795.5						
									16216	16796.0	16796.0						
									16217	16796.5	16796.5						
									16218	16797.0	16797.0						
									16219	16797.5	16797.5						
									16220	16798.0	16798.0						
									16221	16798.5	16798.5						
									16222	16799.0	16799.0						
									16223	16799.5	16799.5						
									16224	16800.0	16800.0						
									16225	16800.5	16800.5						
									16226	16801.0	16801.0						
									16227	16801.5	16801.5						
									16228	16802.0	16802.0						
									16229	16802.5	16802.5						
									16230	16803.0	16803.0						
									16231	16803.5	16803.5						
									16232	16804.0	16804.0						
									16233	16804.5	16804.5						
									16234	16805.0	16805.0						
									16235	16805.5	16805.5						
									16236	16806.0	16806.0						

# APPENDIX 2 INTERNATIONAL TELEX ABBREVIATIONS

---

Abbreviation	Meaning
ADV	Advise
ACK	Acknowledge
AGN	Again
BI (GS)	Good bye
BK	I cut off.
CFM	Confirm
COL	Collation
CRV	How do you receive?
DER	Out of order
DWN	Down
EEE	Error
FM	From
GA	Go ahead.
MNS	Minutes
MOM	Wait (Waiting)
MUTI	Mutilated
NA	Correspondence to this subscriber is not admitted.
NC	No circuits
NCH	Subscriber's number has been changed.
NP	The called party is not or no longer is a subscriber.
NR	Indicate your call number.
OCC	Subscriber is engaged.
OK	Agreed.
P (or 0)	Stop your transmission.
PLS (PSE)	Please
PPR	Paper
R (RCD)	Received
RAP	I will call you again.
RD	Read
RE	Referring to
RPT	Repeat
SRY	Sorry
SVP	Please
TAX	What is the charge?
TEST MSG	Please send a test message?
THRU	You are in communication with telex position
TKS (TNX)	Thanks
TLX	Telex

This page is intentionally left blank.



***Inmarsat C***

---

***Part***

5



# CONTENTS

---

**MENU TREE ..... vii**  
**OPERATIONAL OVERVIEW ..... viii**

**FOREWORD ..... 1**  
Introduction ..... 1  
Features..... 2  
About This Manual ..... 3  
FELCOM 12 System Configuration..... 4

**INMARSAT-C SYSTEM ..... 5**  
Introduction ..... 5  
Inmarsat System Configuration ..... 6  
Communications Network ..... 9  
    Types of MES ..... 10  
Peripheral Equipment ..... 11  
    Distress/Urgent Receiving Call Unit (IC-303) ..... 11  
    Distress Alert Unit (IC-302) ..... 11  
    Distress Message Controller (DMC-5: Option) ..... 11

**OPERATIONAL OVERVIEW ..... 1-1**  
The Communication Unit ..... 1-1  
    Self test ..... 1-1  
    When the audible alarm sounds..... 1-1  
The Terminal Unit..... 1-2  
    Floppy disk drive..... 1-2  
    Floppy disk ..... 1-2  
Printer PP-510 (optional supply) ..... 1-3  
Keyboard ..... 1-4  
    Key description..... 1-4  
    Shortcut key operation..... 1-6  
Function Menus ..... 1-6  
    Selecting menu, menu options..... 1-7  
    Function menu description ..... 1-7  
    Sample menu operation ..... 1-8  
Display Indications ..... 1-9  
Error Messages and Alerts ..... 1-11  
Silencing the Audible Alarm..... 1-12  
    Silencing the alarm by the Setup menu ..... 1-12  
Using a Personal Computer as a Terminal Unit..... 1-13  
    PC requirements ..... 1-13  
    Installing the program..... 1-13  
    Contents of program disk ..... 1-14

## **SYSTEM INITIALIZATION .....2-1**

System Settings.....	2-1
Two sets of DTEs installed .....	2-1
System setup .....	2-2
Terminal Setup.....	2-6
Login and Logout .....	2-7
Login.....	2-8
Logout.....	2-9
EGC Settings .....	2-11
What is the EGC (Enhanced Group Call) service?.....	2-11
EGC setup.....	2-12
Programming EGC channels .....	2-15
Programming NCS Channels.....	2-16
LES List Operations .....	2-18
Programming the LES list .....	2-18
Deleting and changing the LES list .....	2-20
Printing the LES list .....	2-20
Station List Operations .....	2-22
Programming the station list.....	2-22
Editing the station list .....	2-25
Printing the station list.....	2-25
Entering Own Ship's Position.....	2-26
Setting Directories .....	2-27
E-mail Service List .....	2-28
E-mail Setup .....	2-30

## **FILE OPERATIONS .....3-1**

Preparing a Message .....	3-1
Preparing a routine message .....	3-1
Preparing a confidential message .....	3-2
Editor menu setup.....	3-3
Cutting and pasting text .....	3-4
Copying and pasting text .....	3-5
Insert (with Citation) .....	3-6
Select All .....	3-6
Search and Replace.....	3-6
Go to line .....	3-6
Time or Pos. ins .....	3-6
Saving a Message .....	3-7
Formatting a floppy disk .....	3-7
Saving a message.....	3-8
Opening a File .....	3-10
Opening a file .....	3-10
Switching between files.....	3-11
Opening a file where a working area is occupied.....	3-11
Saving a File Under a New Name .....	3-12
Printing a File .....	3-13
Combining Files .....	3-14
Deleting a File .....	3-14
MIME (Multipurpose Internet Mail Extensions).....	3-15
Rename .....	3-16

## **INMARSAT-C COMMUNICATIONS .....4-1**

Transmitting.....	4-1
Code description.....	4-1
Transmitting prepared message .....	4-2
Transmitting message stored on floppy disk (multiple address) .....	4-9
Canceling transmission.....	4-13
Confirming delivery status (message status list) .....	4-14
Manually requesting delivery status .....	4-16
The 2-digit code services.....	4-17
Inserting the destinations of a fax terminal .....	4-19
Receiving .....	4-20
When a message is received .....	4-20
Setting the receive alarm .....	4-21
Displaying receive messages .....	4-22
Printing receive messages.....	4-23
Saving receive messages to a floppy disk .....	4-24
Automatically saving receive messages .....	4-24
Deleting receive messages.....	4-25
Distress/Urgent Receiving Call Unit IC-303.....	4-26
Display Log .....	4-26
Displaying and printing the display log.....	4-26
Automatic printing of display log.....	4-27
Display send message log or receive message log .....	4-28
EGC Messages.....	4-28
Displaying and reprinting EGC messages .....	4-28
Displaying EGC closed network ID (ENID).....	4-29
Receiving EGC distress or urgent message .....	4-30

## **DATA REPORTING AND POLLING .....5-1**

Data Reporting.....	5-1
Setting a data report.....	5-1
Setting a message report .....	5-4
Polling.....	5-6
Polling command.....	5-6
Polling reception.....	5-7
DNID (Data Network Identification).....	5-8
Displaying DNID .....	5-8
Enabling/Disabling DNID .....	5-9

## **DISTRESS ALERT.....6-1**

Preparing a Distress Alert .....	6-1
Transmitting a Distress Alert .....	6-3
Testing Distress Button.....	6-4
Distress Communications .....	6-5

**OTHER FUNCTIONS ..... 7-1**

Aborting an Operation ..... 7-1  
Scanning NCS ..... 7-2  
Selecting EGC Receiving Channel ..... 7-3  
Selecting NCS Channel ..... 7-4

**MAINTENANCE ..... 8-1**

Safety Information ..... 8-1  
General Checking and Maintenance ..... 8-2  
    Cleaning the terminal unit and communication unit ..... 8-2  
    Checking connectors and earth terminal ..... 8-2  
    Floppy disk drive head ..... 8-2  
    When the power can't be turned on (power lamp does not light) ..... 8-2  
Self Tests ..... 8-3  
    Self test at power application (communication unit) ..... 8-3  
    Testing the communication unit through the keyboard ..... 8-3  
Performance Verification (PV) Test ..... 8-4  
    PV test sequence ..... 8-4  
    PV test procedure ..... 8-5  
    Results of PV test ..... 8-6  
System Status Monitor ..... 8-7  
    Interpreting the system status monitor ..... 8-8  
Replacing Internal Battery ..... 8-9

**APPENDIX ..... AP-1**

International Telex/Telephone Country Code List ..... AP-1  
International Telex Abbreviations ..... AP-9  
Glossary of Acronyms ..... AP-10  
International Telegraphy Alphabet ..... AP-11  
Error Messages and Alerts ..... AP-12  
LES IDs List ..... AP-15

# MENU TREE

Numerals in parenthesis are page numbers.

## F1: File

- 1: New ALT-N (3-1)
- 2: Open ALT-O (3-10)
- 3: Close ALT-Q (3-9)
- 4: Save ALT-S (3-12)
- 5: Delete ALT-D (3-14)
- 6: Rename (3-15)
- 7: Print ALT-P (3-13)
- 8: Format Disk (3-7)(IB-581 only)
- 9: MIME (Decode) (3-15)
- 9: QUIT (PC only)

## F2: Edit

- 1: Cut DEL (3-4)
- 2: Copy ALT-C (3-5)
- 3: Paste INS (3-5)
- 4: Insert (with Citation) (3-5)
- 5: Select All ALT-A (3-5)
- 6: Search or Replace (3-5)
- 7: Go to line
  - 1: Top of Text Fn← (3-5)
  - 2: End of Text Fn→ (3-5)
  - 3: Go to Line (3-5)
- 8: Time or Pos. Ins (3-5)
- 9: Change Window ALT-V (3-11)

## F3: Transmit

- 1: Transmit Message (4-2, 4-9)
- 2: Cancel (4-13)
- 3: Request Delivery Status (4-14)

## F4: EGC

- 1: Display EGC Message (4-28)
- 2: EGC Network ID (4-29)

## F5: Reports

- 1: Data Report (5-1)
- 2: Message Report (5-4)
- 3: Date Network ID (5-8)

## F6: Logs

- 1: Send Message Log (4-28)
- 2: Receive Message Log (4-22)
- 3: EGC Log (4-28)
- 4: Log (4-26)

## F7: Options

- 1: Login (2-7)
- 2: Logout (2-9)
- 3: Abort (7-1)
- 4: Select NCS (7-4)
- 5: Ocean Region (7-2)
- 6: Test (5-4, 8-3)

## F8: Setup

- 1: Distress Alert Setup (6-1)
- 2: System Setup (2-2)
- 3: Editor Setup (3-3)
- 4: Terminal Setup (2-1)
- 5: EGC Setup (2-11)
- 6: Auto Mode Setup (4-21, 4-24, 4-27)
- 7: E-Mail Setup (2-30)
- 8: Directories (2-27)
- 9: Configuration
  - 1: Station List (2-22, 2-25)
  - 2: LES List (2-20, 2-18)
  - 3: EGC Channel List (2-15, 7-3)
  - 4: NCS Channel List (2-16)
  - 5: E-Mail Service List (2-28)

F9: Position (2-26)

F10: Stop Alarm (1-1)

# OPERATIONAL OVERVIEW

---

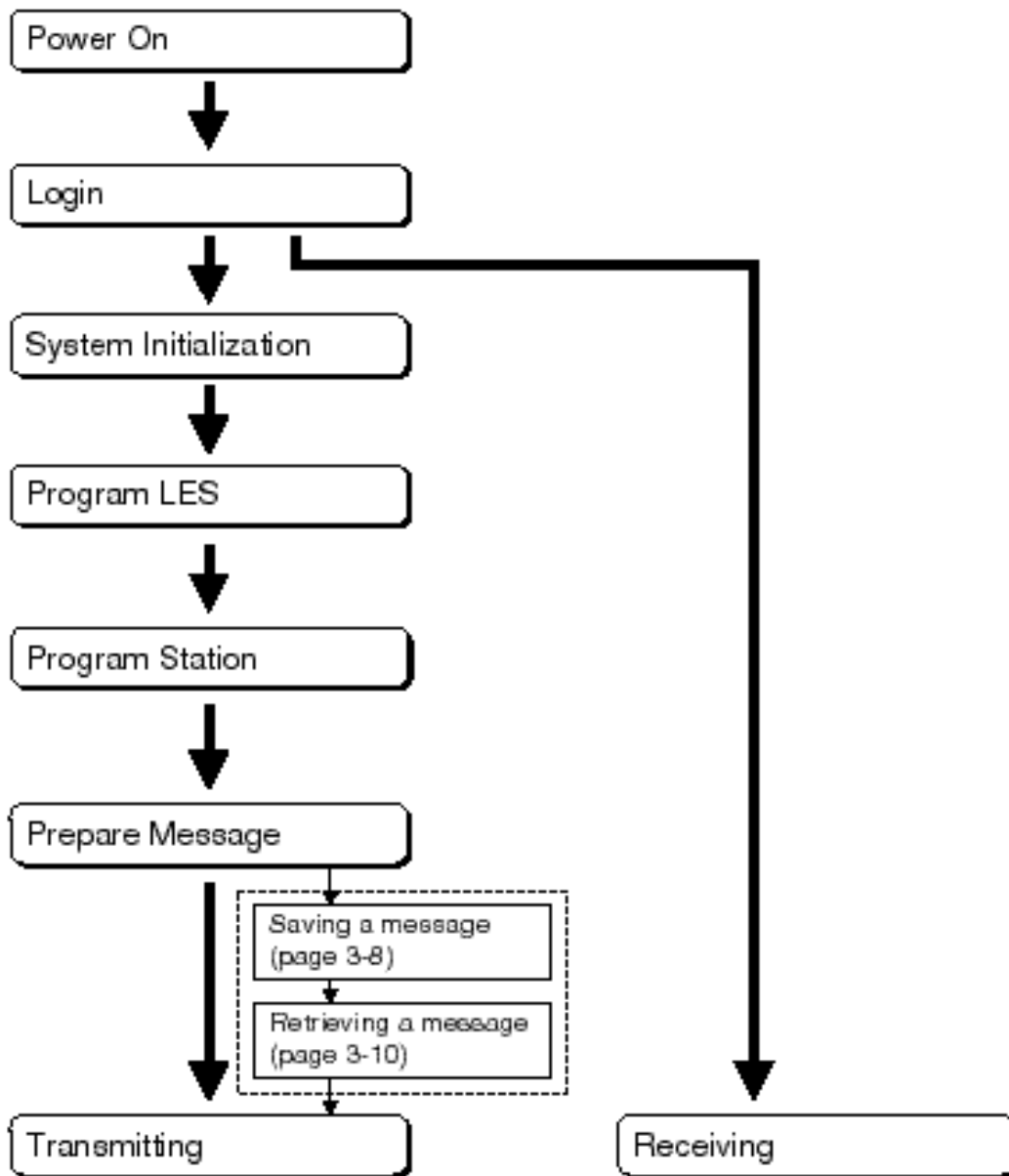

The FELCOM 12 should be turned on for the duration of a voyage.  
Be sure to logout with Inmarsat-C system before turning off the equipment.

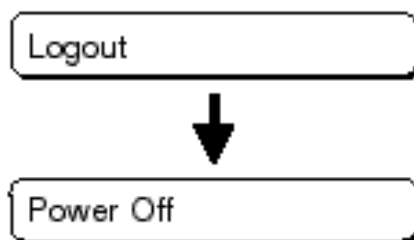



## Introduction

FURUNO Electric Company thanks you for considering and purchasing the FELCOM 12 Inmarsat-C Mobile Earth Station. We are confident you will discover why the FURUNO name has become synonymous with quality and reliability.

Mainly consisting of an antenna unit, a communication unit and terminal unit, the FELCOM 12 provides the full range of distress and general communication services for mobile and fixed terrestrial subscribers in the Inmarsat-C communication network. Its compact size permits installation where space is limited.

FURUNO designs and manufactures this equipment with much attention to operation and maintenance simplicity. However, please read and follow the recommended procedures for operation and maintenance to get the most out of the equipment.

This manual provides a brief introduction to the Inmarsat-C system (pages 5 thru 10). For more detailed information, however, please refer to "Inmarsat-C Maritime User's Manual" published by Inmarsat. (It is free of charge.) Below are contact points for Inmarsat.

*Inmarsat-C Maritime Customer Relations Officer  
Maritime Services Operations Department  
International Maritime Satellite Organization (Inmarsat)*

*Address: 99 City Road, London EC1Y 1AX, UK*

*Telephone: +44 71 728 1000 (Switchboard)*

*Fax: +44 71 728 1192*

*Telex: 297201 Inmarsat G*

# Features

- E-mail facility  
To transmit E-mail, register with the LES provider. E-mail charges are calculated separately.
- Built in Enhanced Group Call (EGC) receiver permits operation as EGC-only receiver.
- Communication unit accepts a wide variety of peripheral equipment, Distress Message Controller (DMC), personal computer and remote panel.
- Connection of 2nd Data Terminating Equipment (DTE) for operation from remote location such as the bridge
- Store-and-forward telex communication (public telex network)
- Data reporting and Polling
- Internal GPS receiver (option) in the communication unit provides GPS-generated position.
- Self test programs for maintenance
- Terminal unit provides floppy disk drive for unlimited storage of received and transmitted messages on floppy disks.
- Menu driven operation

# About This Manual

A word about the organization of this manual: It is laid out in a user-friendly manner as possible. We realize a machine like this with its many, many functions can be a little intimidating to even the experienced MES operator. This is why we have arranged this manual in a series of sections that start at a basic level and proceed forward in complexity in a logical manner.

The best way to acquaint yourself with the many facilities this equipment has to offer is to turn it on and try keying in the examples provided in each of the sections. In hardly no time at all you'll be enjoying the benefits of the Inmarsat-C system.

**Inmarsat-C System** This chapter explains the Inmarsat-C system.

**Operational Overview** This chapter introduces basic operations.

**System Initialization** Read this chapter to learn how to initialize the FELCOM 12.

**File Operations** You will learn how to use the text editor in this chapter, to prepare, edit and save messages.

**Inmarsat-C Communications** Read this chapter to learn how to transmit and receive in the Inmarsat-C system.

**Data Reporting and Polling** This chapter explains data reporting setting and polling reception.

**Distress Alert** This chapter tells you how to prepare and transmit the distress alert, and conduct distress communications.

**Other Functions** This chapter describes how to abort operation, scan NCS, and select various channels.

**Maintenance** The maintenance chapter presents information for keeping the FELCOM 12 in top operating condition.

**Appendix** The Appendix presents international telex country codes, international telex abbreviations, glossary of acronyms, error messages and alerts, and international telegraphy alphabet.

# FELCOM 12 System Configuration

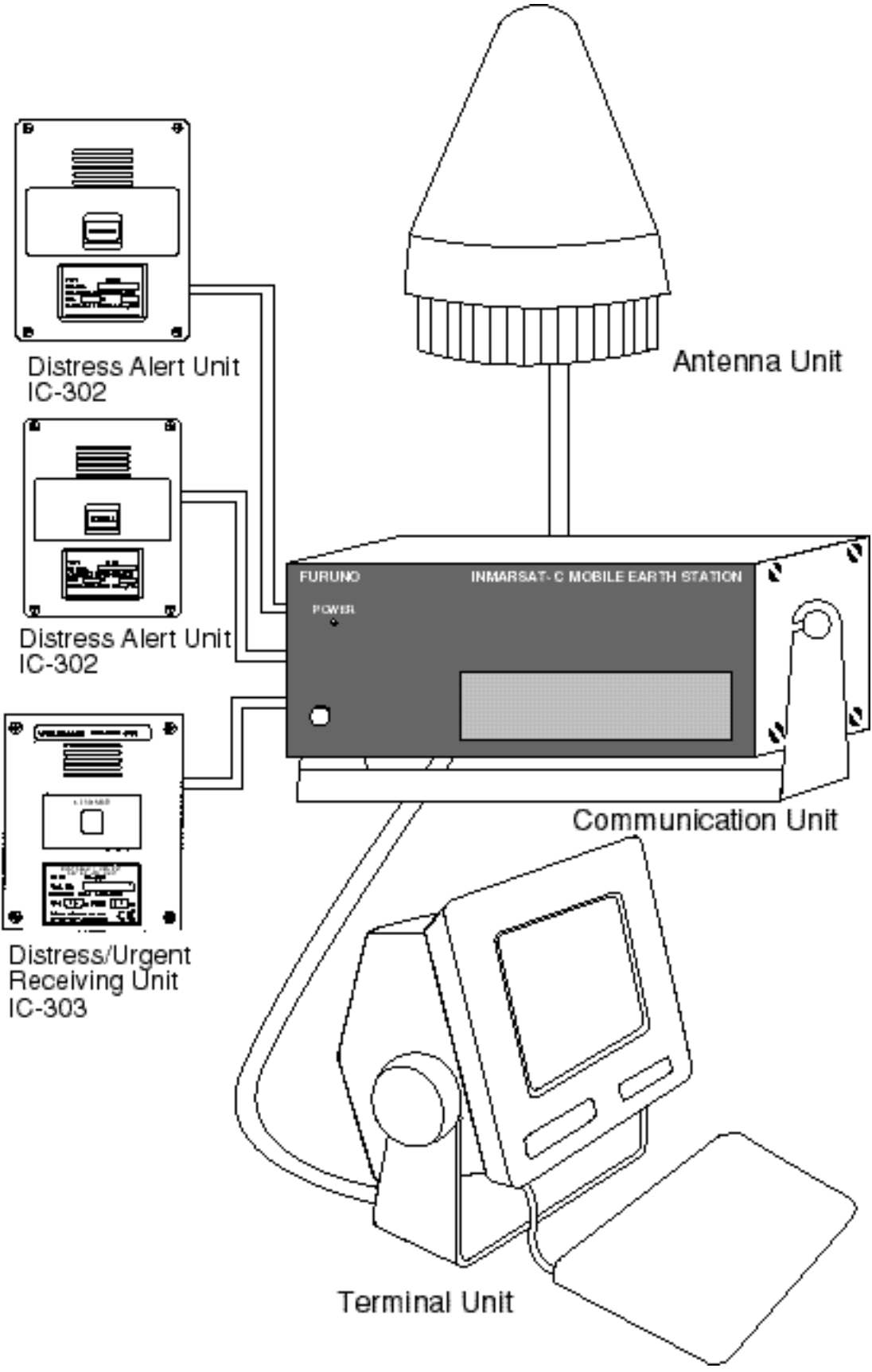

Figure 1 FELCOM 12 system configuration

# INMARSAT-C SYSTEM

---

This chapter provides an overview of the Inmarsat-C satellite communication system.

## Introduction

The Inmarsat-C system provides worldwide telex and data transmission and reception of written information to owners of an Inmarsat-C transceiver or a terrestrial telex network via satellite.

Communication mode is store-and-forward telex, which means all information sent are first stored at a LES and then delivered to designated party.

An EGC (Enhanced Group Call) receiver is built in the FELCOM 12 to receive the following types of messages, broadcast from a LES:

- SafetyNET™-governments and maritime authorities can use this service to distribute maritime safety information to ships within selected areas.
- FleetNET™-commercial subscription organizations or shipping companies can use this service to transmit trade information (for example, company news or market prices) simultaneously to a selected group of ships, to provide up-to-the-minute information.

FELCOM 12 allows you to make *distress calls* which are given immediate priority over all other calls, and are automatically routed to a land-based *Rescue Co-ordination Centre (RCC)*.

Besides its primary application of ship-shore, shore-ship or ship-ship communications, the Inmarsat-C service has also proved beneficial to trucking firms who have found it indispensable for communicating with their vehicles. In this manual, however, we will concentrate on ship applications, the main application.

# Inmarsat System Configuration

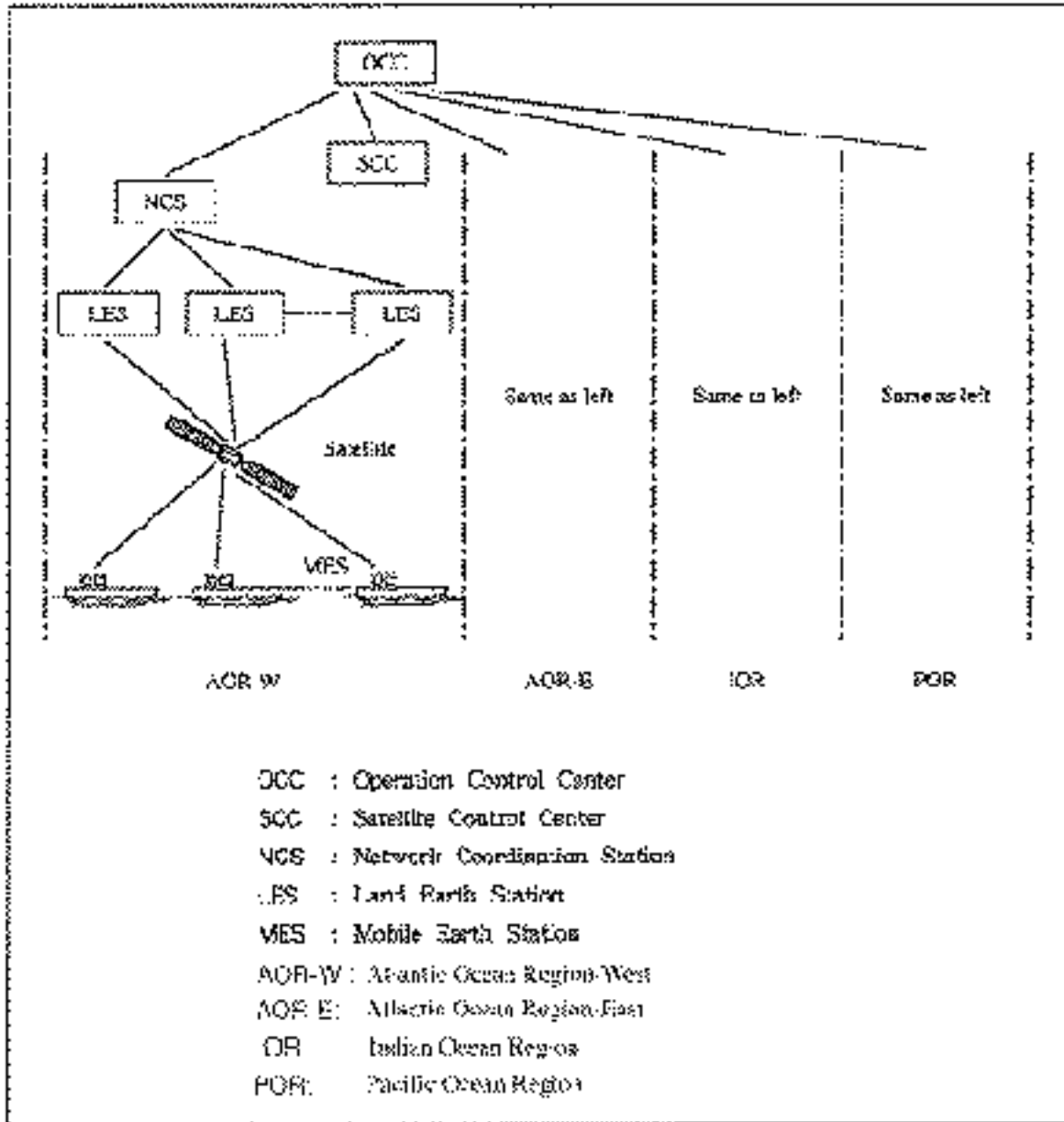

Figure 2 Inmarsat-C satellite communication system

The Inmarsat-C system consists of the Operation Control Center (OCC), Satellite Control Centers (SCC), Network Coordination Stations (NCS), Land Earth Stations (LES) and Mobile Earth Stations (MES). The OCC, located at Inmarsat's London headquarters, coordinates a wide range of activities in the Inmarsat system, including commissioning of mobile earth stations.

The Inmarsat-C system divides the world into four regions and each region is covered by its own satellite.

*Table 1 Inmarsat system satellites*

<b>Region</b>	<b>Satellite</b>	<b>Satellite Position</b>
AOR-West	Inmarsat-2, F4	54.0°W
AOR-East	Inmarsat-2, F2	15.5°W
IOR	Inmarsat-2, F1	64.5°E
POR	Inmarsat-2, F3	178.0°E

In each region there is one NCS and several LESs. The NCS keeps track of all Inmarsat-C transceivers in its region and broadcasts information such as navigational warnings, weather reports and news. The LES provides the link between the MES and the terrestrial telecommunications networks via satellite.

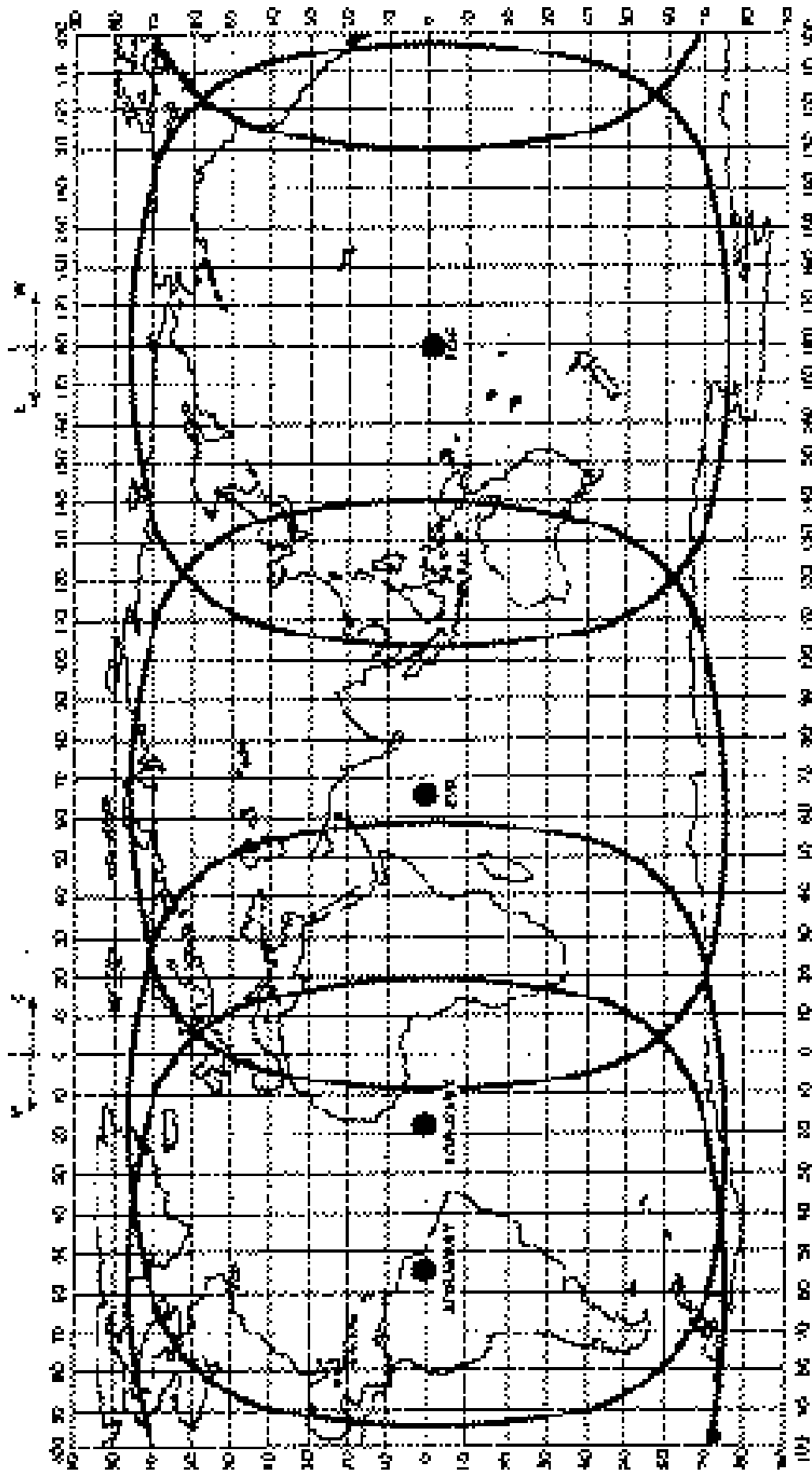

Figure 3 Coverage area of satellites



# Communications Network

Figure 4 shows the Inmarsat-C communications network.

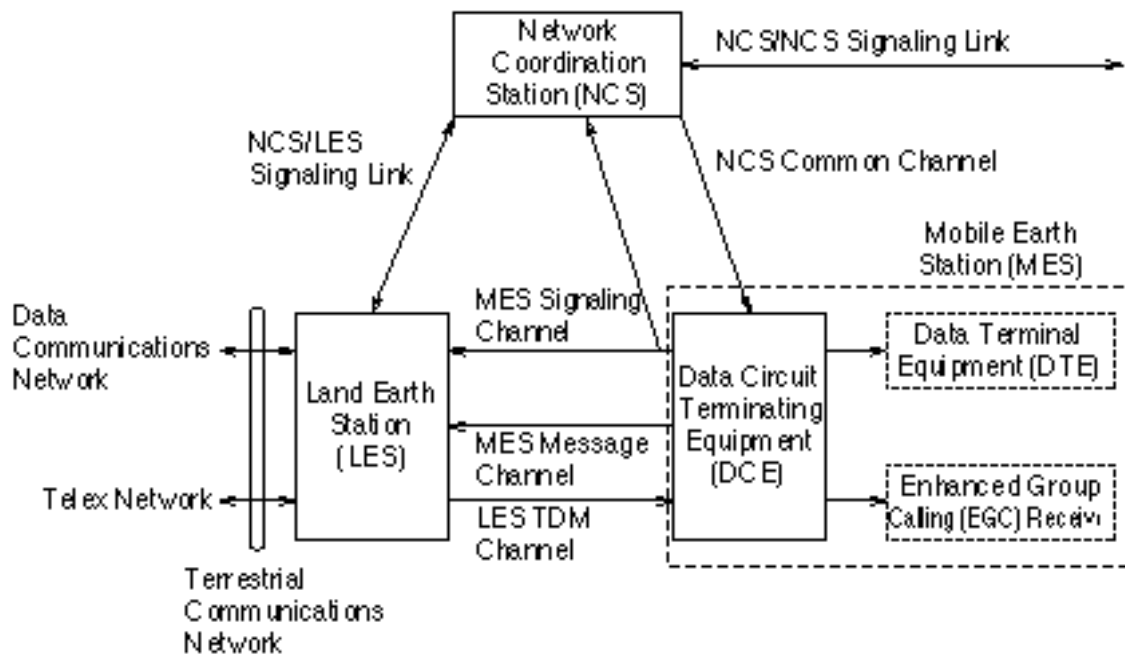

Figure 4 Inmarsat-C communications network

- NCS common channel** The NCS has two major functions:
- 1) Transmitting information on a common channel.
  - 2) Transmitting EGC messages to MESs.
- NCS/LES signalling link** This is the link between NCS and all LESs in its region. All EGC messages pass through this link.
- LES TDM channel** This channel carries the circuit control signal for MES and transmits messages from LES to MES.
- MES message channel** This channel carries messages from MES to LES.
- MES signaling channel** This channel transmits requests, distress alerts, data reports, etc. In addition, it carries login and logout from MES to NCS.
- NCS/NCS signaling link** This is the link between NCSs. It exchanges data between MESs operating in different ocean regions.

**MES interface**

The MES consists of the Data Circuit Terminating Equipment (DCE) and the Data Terminal Equipment (DTE). The DCE consists of the antenna unit and the communication unit. And the DTE consists of the terminal unit (or a PC), keyboard and printer.

**Terrestrial network interface**

The major functions of the LESs are:

- 1) Telex store-and-forward conversion
- 2) Handling EGC messages
- 3) Handling distress alerts
- 4) Data Reporting and Polling

**Types of MES**

There are three types of MES: class 1, class 2 and class 3. The FELCOM 12 is a class 2 MES.

**Class 1**

- 1) Transmits messages to LES
- 2) Receives messages from LES

**Class 2**

- 1) The functions of class 1 plus operation as an EGC receiver when not transmitting or receiving.
- 2) EGC-only receiver

**Class 3**

The function of class 1 plus simultaneous operation as a EGC-only receiver.

# Peripheral Equipment

The following equipment can be additionally connected to the FELCOM 12.

## Distress/Urgent Receiving Unit (IC-303)

The IC-303 releases an audible alarm and blinks the lamp when distress message is received. (Refer to page 4-26 for further details.) When an EGC distress or urgent message is received, with an aural alarm and blinking lamp.

## Distress Alert Unit (IC-302)

The IC-302 enables transmission of the distress alert from a remote location; for example, ship's bridge. (Refer to page 6-3 for more details.)

## Distress Message Controller (DMC-5:Option)

The DMC provides for transmission and monitoring of the distress alert. For further details, refer to the operator's manual of the DMC-5.

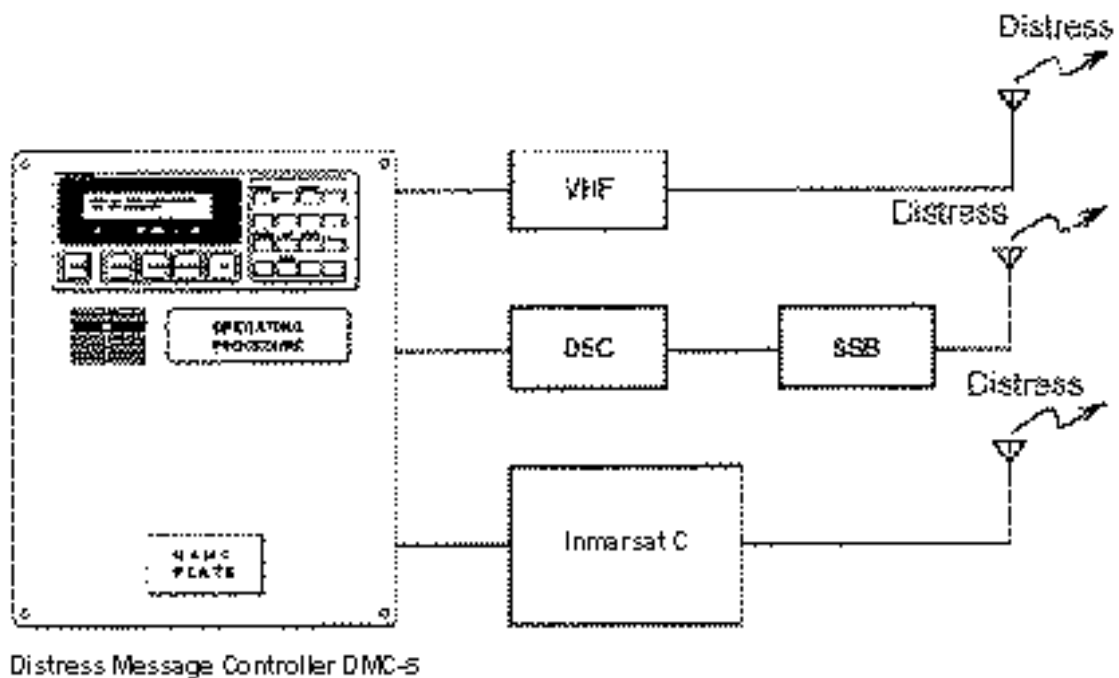

Figure 5 Distress Message Controller system

This page is intentionally left blank.

# OPERATIONAL OVERVIEW

---

This chapter provides an overview of the FELCOM 12 system.

## The Communication Unit

The communication unit is the heart of the FELCOM 12 system, transmitting and receiving messages and alerting you to equipment fault.

On its front panel you should see the POWER switch and POWER lamp. Normally, the power is left on while underway.

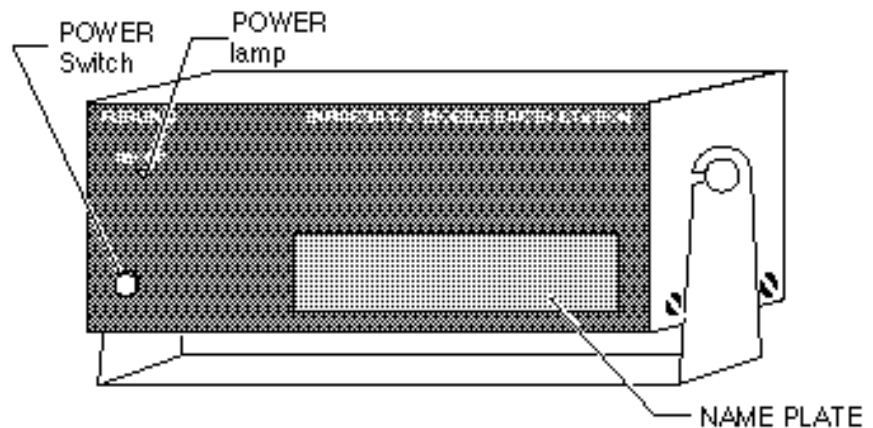

*Figure 1-1 Communication unit IC-212*

### Self test

When the communication unit is turned on it conducts a series of self-tests to check itself for proper operation.

### When the audible alarm sounds

The audible alarm sounds in the following circumstances:

- 1) EGC distress or urgent message is received. (To silence the alarm, press [ESC] followed by [F10].)
- 2) During the interval between the transmission of the distress alert (by own vessel) and the receiving of the distress acknowledge signal from LES. (The alarm automatically stops when your ship receives the distress acknowledge signal.)
- 3) The system status monitor detects equipment fault. (To silence the alarm, press any key.)

The audible alarm sounds and the terminal unit displays which alarm is sounding.

# The Terminal Unit

The DTE may consist of IB-581 or IBM compatible pc. All operations are carried out from the terminal unit, through an easy-to-understand menu system. For personal computer connection a system disk (supplied) is required to boot up the computer. Operation by a computer is the same as with the terminal unit except when turning on the power.

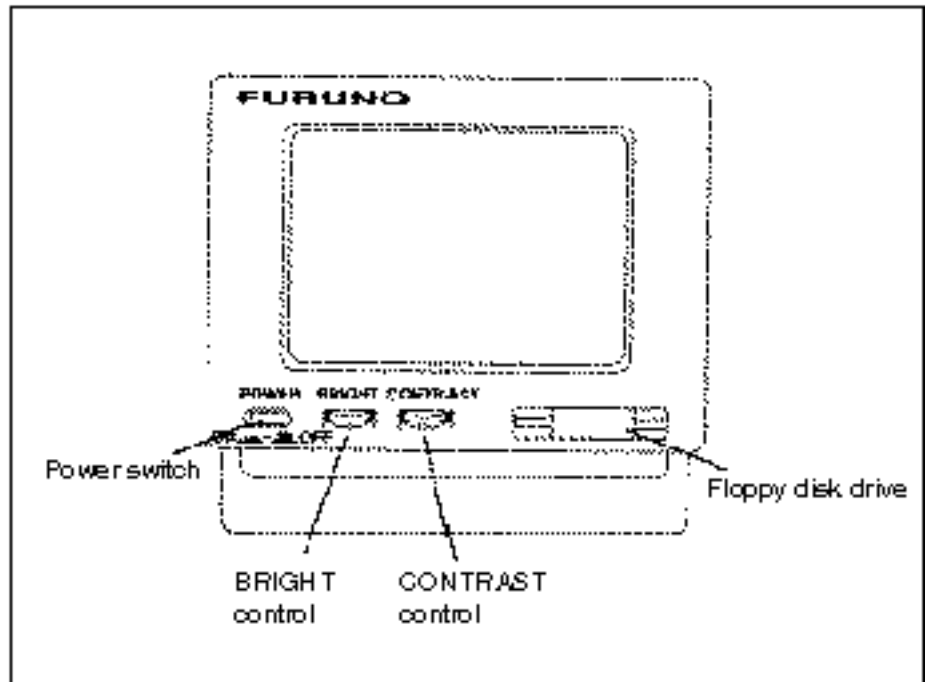

*Figure 1-2 Terminal unit IB-581*

To turn on/off the unit, press the POWER switch.

Controls for adjustment of screen brilliance and contrast are to the right of the POWER switch.

## Floppy disk drive

The terminal unit provides a floppy disk drive for storing transmitted and received messages on floppy disks.

## Floppy disk

The floppy disk used with the system is a standard 3.5" floppy disk. Always leave a floppy disk inserted to save incoming messages.

Terminal unit cannot print file from a floppy disk when there is not enough space remaining on the disk. In this case, replace disk with formatted disk.

# Printer PP-510 (optional supply)

The printer prints transmitted and received messages. The POWER switch is on the right side of the unit. A lamp on the switch lights when the power is on. If the paper is set correctly the ON LINE lamp also lights. When both these lamps are lit the printer is ready to print information received from the terminal unit. For further details, refer to the operator's manual of the PP-510.

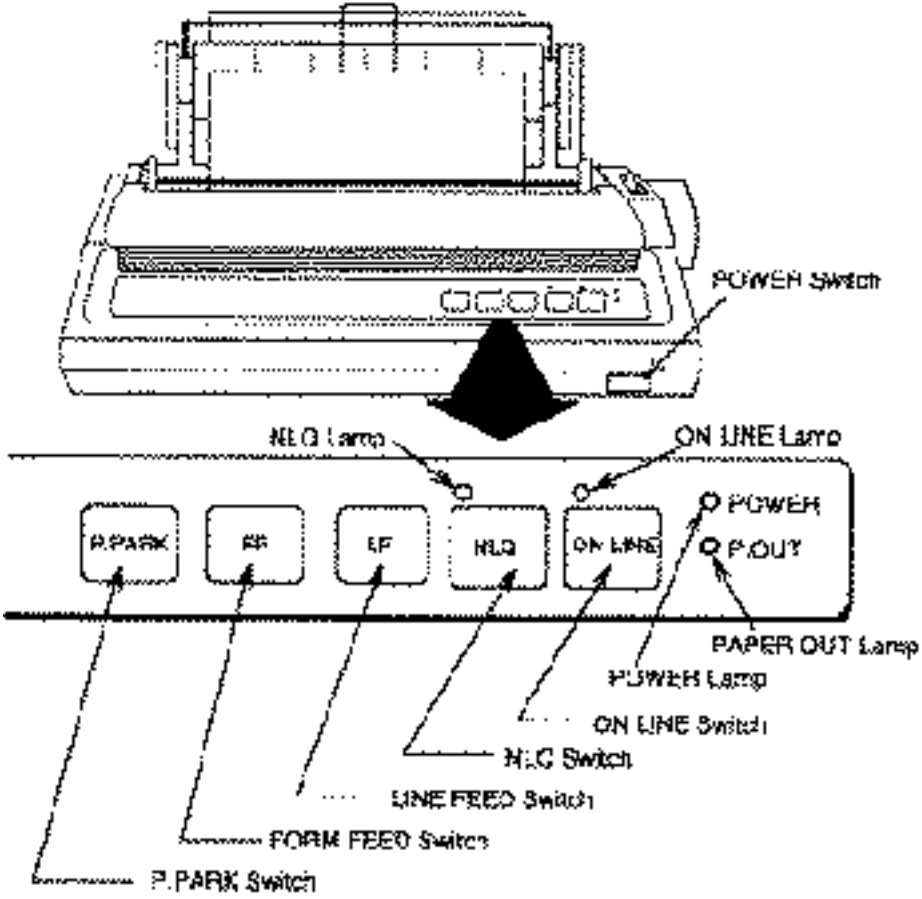

Figure 1-3 Printer PP-510

# Keyboard

The FELCOM 12 is almost 100% keyboard controlled. Operation is simplified by the use of menus which you access by pressing function keys, numbered F1-F10 at the top of the keyboard. Figure 1-4 shows keyboard layout.

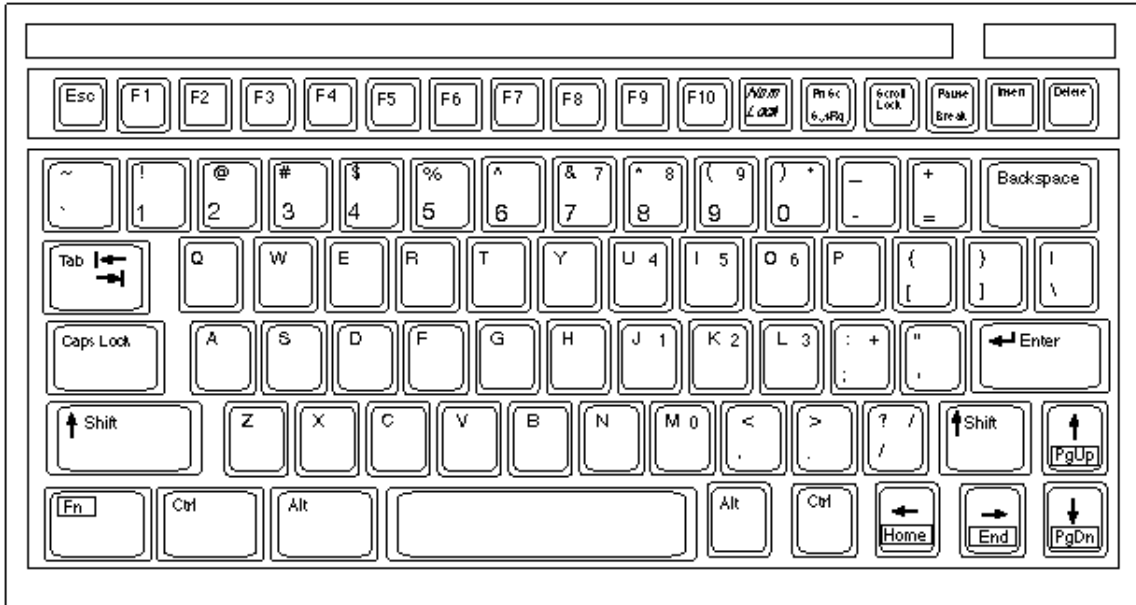

Figure 1-4 Keyboard

## Key description

<b>Esc</b>	Cancels key input and returns to previous display screen.
<b>F1-F10</b>	These are the function keys. They select menus.
<b>Backspace</b>	Deletes the character to the left of the cursor.
<b>Insert</b>	Works the same as PASTE function. See page 3-5.
<b>Delete</b>	Deletes the character on the cursor.
<b>Home</b>	Moves the cursor to the top of a message being edited.
<b>End</b>	Moves the cursor to the bottom of a message being edited.
<b>PgUp</b>	Goes to the previous page of the edit screen.
<b>PgDn</b>	Goes to the next page of the edit screen.
<b>[↑], [↓], [←], [→]</b>	Control the cursor.
<b>Enter</b>	Registers key input.



- Shift** Selects upper or lower case letters. Press and hold down the key to get upper case letters. Note that only upper case letters are used in telex.
- Alt** Executes the shortcut key operation when combined with an alphabet key.
- Space Bar** Inserts a space. In addition, it displays file list, partial view of a file, etc. depending on menu.
- Caps Lock** Turns upper case letter input on or off. CAPS appears on the display when the keyboard is set for upper case letter input.
- Tab** Inserts horizontal tab characters. The number of tab characters the key can insert per line of text can be programmed for two, four or eight tabs.
- Ctrl** Works in combination with alphabet keys as follows:

*Table 1-1 Ctrl key shortcuts*

Ctrl+[M]	Same as Enter.
Ctrl+[H]	Same as Back Space.
Ctrl+[I]	Same as Tab.

- FN** Combined with an arrow Key, it scrolls screen( ↑ , ↓ ),or shifts cursor (←, →).
- Num Lock** Turns numeric input on or off. Note that you cannot enter alphabet when the Num LED is its.

**Note:** *In telex, lower case, #, &, \*, \$ or % are not used. A full list of characters usable in telex appears on page A-11 in the Appendix.*

## Shortcut key operation

The FELCOM 12 provides the keyboard shortcuts shown below for commonly used functions.

*Table 1-2 Shortcut keys*

Short Cut key	Operation
ALT+N	Same as NEW in File menu
ALT+O	Same as OPEN in File menu
ALT+Q	Same as CLOSE in File menu
ALT+D	Same as DELETE in File menu
ALT+S	Same as SAVE in File menu
ALT+P	Same as PRINT in File menu
ALT+X	Same as UNDO
DELETE	Same as CUT in Edit menu
ALT+C	Same as COPY in Edit menu
INSERT	Same as PASTE in Edit menu
Fn+← (Home)	Same as Top of Text in Edit/Go to line menu
Fn+→ (End)	Same as End of Text in Edit/Go to line menu
ALT+V	Same as CHANGE WINDOW in Edit menu

## Function Menus

The function menus, which you access by pressing the function keys (F1-F10) at the top of the keyboard, control most operations of this unit.

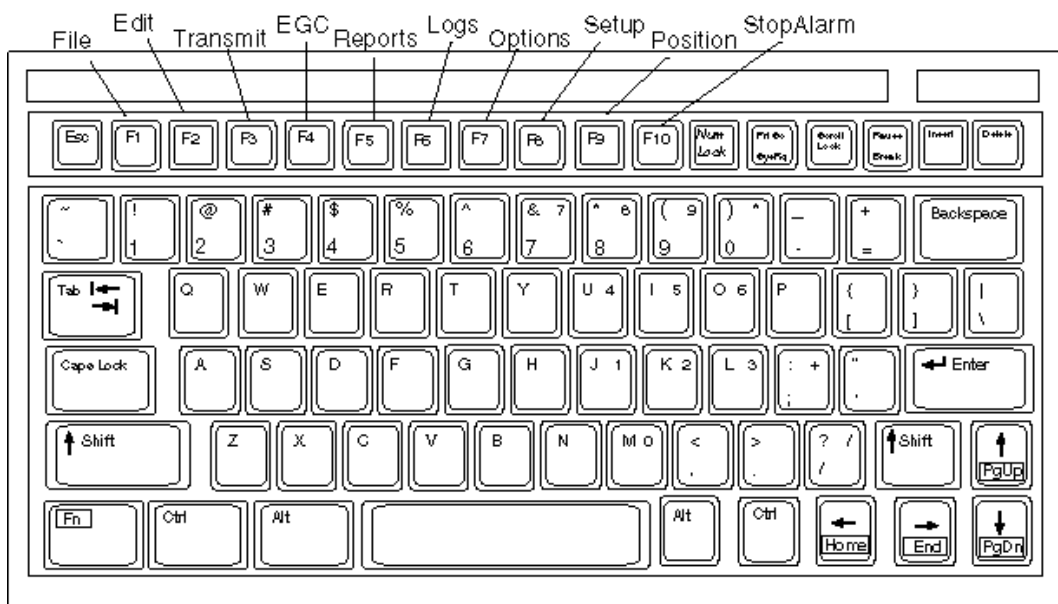

*Figure 1-5 Keyboard, showing function menu keys*

## Selecting menu, menu options

Press appropriate function key to select a menu. For example, press [F1] to select the File menu.

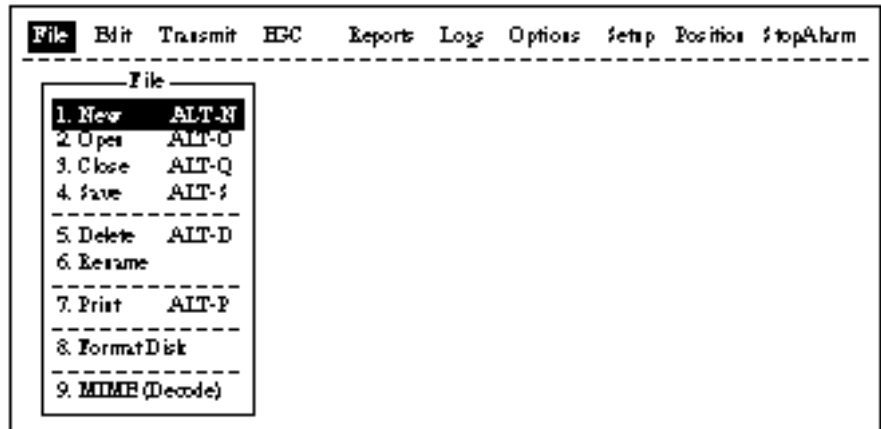

*Figure 1-6 File menu*

You may select menu options with the arrow keys (pressing [Enter] after making selection) or appropriate numeric key. As the cursor moves down through a menu, when using the arrow keys, each menu option, initially shown as white on black, reverses to black on white. This highlighting indicates the item is available for selection. In Figure 1-6, for example, “New” is available for selection.

## Function menu description

*Table 1-3 Function menu description*

Menu	Description
File	Processes files.
Edit	Provides text editing facilities.
Transmit	Transmits messages.
EGC	Sets up EGC message facilities.
Reports	Sets up data reporting function.
Logs	Displays send and receive message logs.
Options	Login, logout, testing facilities.
Setup	Sets up the system.
Position	Enters your ship's position.
Stop Alarm	Silences buzzer.

## Sample menu operation

For example, you want to display a transmitted message. All operations begin from the standby display.

File	Edit	Transmit	EGC	Reports	Logs	Options	Setup	Position	StopAlarm
Date			97-09-04			EEER			000
Time			0132 (UTC)			C/N			CK ( 36dB)
						SendLevel			CK ( 0)
Position			LAT			RxDIF AGC Level			CK (13.5)
			LOIN			R.FE Offset Freq			CK ( 0Hz)
Waypoint			LAT			Synthe 1st-1 Local			CK
			LOIN			1st-2 Local			CK
Course			DEG			R.N2nd Local			CK
Speed			KTS						
Current NCS			344 (QOR)	LOGOUT		Antenna Power Supply			CK
Current Channel			NCS OC						
Current TDM			NCS OC			Water Temperature			DEG
MES Status			Idle			Water Current			
GPS Status			****			Detection			DEG
						Speed			KTS
DCE Memory			30919 Bytes free			Depth			
-----									
Current State: IDLE				SYNC (NCS)		97-09-04 0132 (UTC)			
				NCS: IDR		LOGOUT			
DCE Ver >>									

Figure 1-7 Standby display

Press [F6] to display the Logs menu.

File	Edit	Transmit	EGC	Reports	Logs	Options	Setup	Position	StopAlarm
-----									
Log									
1. Send Message Log									
2. Receive Message Log									
3. EGC Log									
4. Log									

Figure 1-8 Logs menu

Press [1] to display the send message log.

File	Edit	Transmit	EGC	Reports	Logs	Options	Setup	Position	StopAlarm
-----									
Log									
1. Send Message Log									
2. Receive Message Log									
Send Message Log									
No.	Message File	Station	LE#	Priority	Send Status	Delivery			

Figure 1-9 Send message log

Select the message you want to display by pressing [↑] or [↓] followed by [Enter].

# Display Indications

The display is divided in three sections:

- 1) The menu area
- 2) The working area
- 3) The operating status area

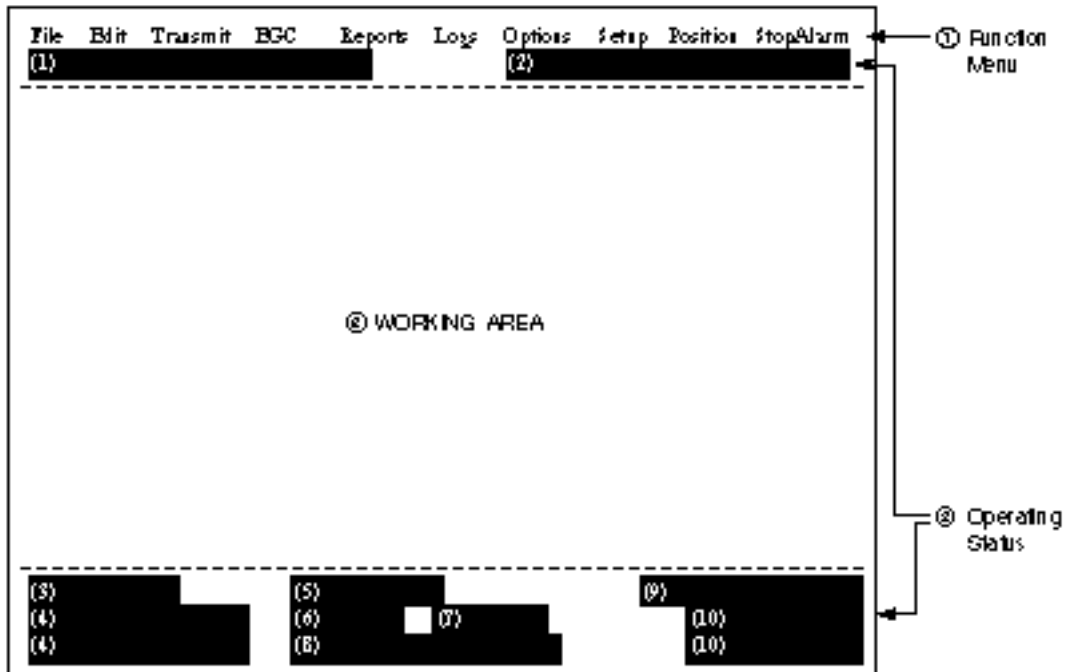

Figure 1-10 Location of display indications

Below are indications and their meanings.

## (1) Distress alert information

- No display (no distress alert)
- Distress Alert Activated
- Distress Alert Test Activated
- Distress Alert Acknowledge Received
- Distress Message Call Activated
- Distress Message Call Acknowledged

## (2) Communication network mode

- |                                       |  |
|---------------------------------------|--|
| No display                            | Normal operation   |
| Restoration Mode (blinking)           | Problem at NCS.  |
| Restoration Mode (reverse indication) | Previously designated LES is transmitting the NCS common channel signal. |

### **(3) Communication unit status**

Idle	Idle (awaiting receiving, awaiting transmitting)
Idle (pending)	Awaiting reply from LES
Sending	During message transmission
Receiving	During receiving
Login	Logging in with NCS
Logout	Logging out with NCS
Distress Alert	When own vessel is transmitting the distress alert
Data Report	During transmission of data report
Testing	PV testing
Test Setup	Requesting PV testing
Scanning	NCS scanning
EGC RECEIVER (reverse indication)	EGC-only receiver operation
Delivery Status Req.	When transmitting delivery status request
Forced Clearing	When stopping receiving, transmitting, or scanning

### **(4) Communication unit remarks and DCE version number**

This area provides remarks about communication unit status.

### **(5) Frame synchronization**

Blank	When changing channel, or during transmission
SYNC (NCS)	Synchronizing with NCS
SYNC (LES)	Synchronizing with LES
UNSYNC	Out of synchronization
Retuning	Synchronizing with NCS or LES

### **(6) Ocean region receiving**

No display	Out of synch with satellite
AOR-W	Atlantic Ocean Region-West
AOR-E	Atlantic Ocean Region-East
IOR	Indian Ocean Region
POR	Pacific Ocean Region

## (7) Logging status

LOGOUT	Logged out with ocean region
LOGIN	Logged in with ocean region
LOGIN (blinking)	Logging in with ocean region

## (8) Other information

No display	No receive message in memory, or printer is operating.
REC. MESSAGE EXISTS (blinking)	Displayed when a routine message has not been printed, or a confidential message is received.
DATA REPORT (Reverse indication)	When data reporting is activated.

## (9) Date and time display

The date (set at system setting) and time (set by satellite) appear. Time is updated every minute (with navigator connection).

## (10) Ship's position

Ship's position (automatic or manual input) appears here.

# Error Messages and Alerts

The terminal unit displays error messages and alerts to call your attention to misoperation, failed operation and system error. A list of error messages and alerts appears on pages A-12 through A-14 in the Appendix. To erase an error or an alert, press [Esc].

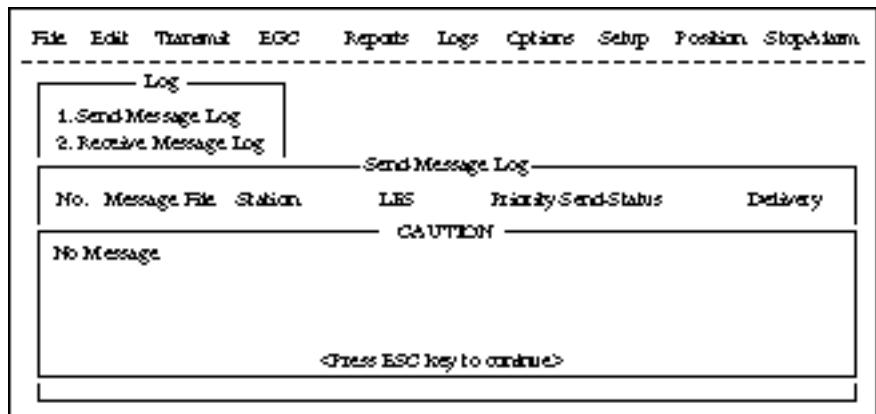

Figure 1-11 Location of error messages and alerts

# Silencing the Audible Alarm

Some error messages and alerts are accompanied by the audible alarm. This alarm can be silenced, in most instances, by pressing any key. If the alarm cannot be silenced in that manner, go to the Setup menu to silence it. Note that the distress alert alarm transmitted by own ship cannot be silenced by either method; it automatically stops when you receive the distress acknowledge signal from LES.

## Silencing the alarm by the Setup menu

1. Press [F8] to display the Setup menu.

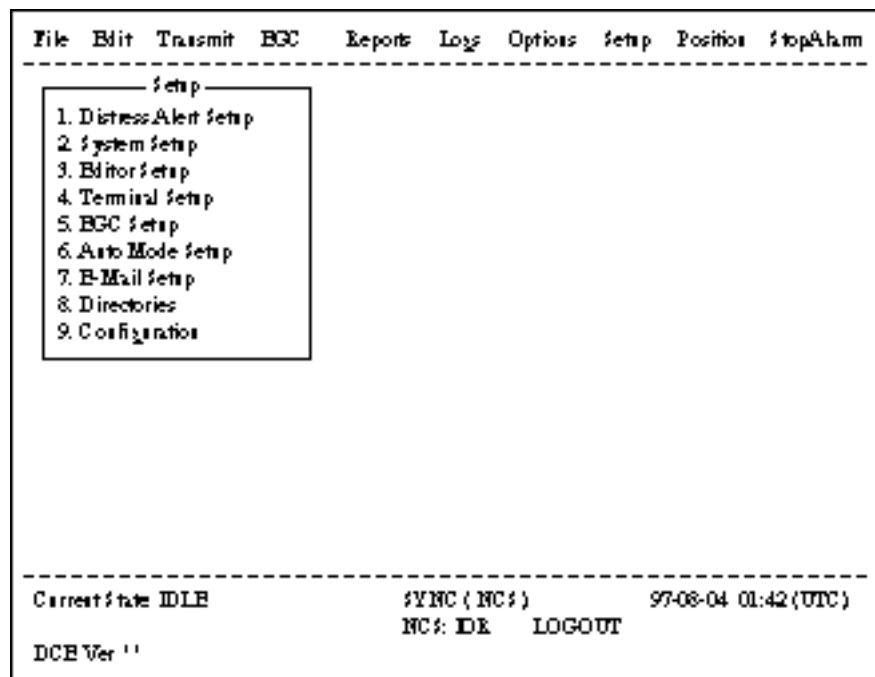

Figure 1-12 Setup menu

2. Press [6] to display the Auto Mode Setup menu.
3. Press [ ↓ ] key to go to the Receive Alarm line.
4. Press [Enter] to open the selection window.

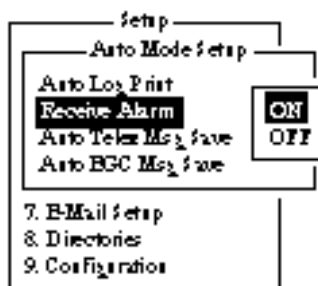

Figure 1-13 Auto mode setup menu



5. Press [ ↓ ] to select OFF.

**Note:** *To silence the audible alarm given to an EGC distress or urgent message from Distress Alert Unit (IC-302), follow the above procedure. DO NOT press the DISTRESS button on the IC-302 to silence the alarm; you will transmit own ship's distress alert.*

6. Press [Enter] to close the selection window.

7. Press [Esc] twice.

## Using a Personal Computer as a Terminal Unit

### PC requirements

Applicable PC:	Toshiba T-2110 or IBM-AT compatible
Memory required:	640K bytes
Graphics:	Any one of CGA/EGA/VGA
Disk Drive:	One 2HD
Operating System:	MS-DOS Version 3.0 or later

### Installing the program

Make the directory "FELCOM12" on the hard disk (drive C) and install the program there as follows;

1. Go to the MS-DOS prompt.
2. Insert the program disk (supplied) in drive A.
3. Type "A:" and press [Enter].
4. Type "PCRINST" in case of main DTE and press [Enter]. The directory MAIL (default directory), where receive messages are automatically saved, is automatically made. To save receive messages to a different directory, use the RD command to delete the MAIL directory. (See "Setting Directories" on page 2-27.)  
Type "PCRINST2" in case of 2nd DTE press [Enter].
5. To install Russian software, type "PCRINST" and press [Enter]. (Russian and English may be switched by pressing left [SHIFT] with left [CTRL] and left [ALT] .)
6. Turn off the power.
7. Turn on the power.
8. Confirm that the software starts up properly.

*Note: You need 128KB (or more) of extended memory in RAM. De-designate extended memory filer (such as HIMEM.SYS) in config.sys file, when extended memory in used.*

## Contents of program disk

READ.ME:	Instructions for installation of software
IBINST.BAT:	English software for IB-581
IBRINST.BAT:	Russian software for IB-581
PCINST.BAT:	English software for PC
PCRINST.BAT:	Russian software for PC
INSTALL.BAT:	Program start up
FELCOM12.EXE:	Terminal software
ENGLISH.DAT:	English text definition file
RUSSIAN.DAT:	Russian text definition file
ENH_FONT.EXE:	Russian driver
DTE.DAT:	Terminal software definition file (for PC)
DTE.B:	Terminal software definition file (for IB-581)
LES.DAT:	LES list
FORMAT.COM:	Format disk

# SYSTEM INITIALIZATION

This chapter provides the information necessary for initializing the FELCOM 12. Once the FELCOM 12 is initialized you need do no more than press a few keys to get fully automatic transmission and reception.

Inmarsat assigns each MES an Inmarsat Mobile Number (IMN). The IMN has already been entered into the FELCOM 12.

## System Settings

### Two sets of DTEs installed

The communication unit provides two sets of connectors (DTE1, main; DTE2, 2nd) for connection of two DTEs. It is preset at the factory for connection with one DTE (main DTE). Main DTE is available to set the menu.

1. Press [F8] to select the Setup menu.

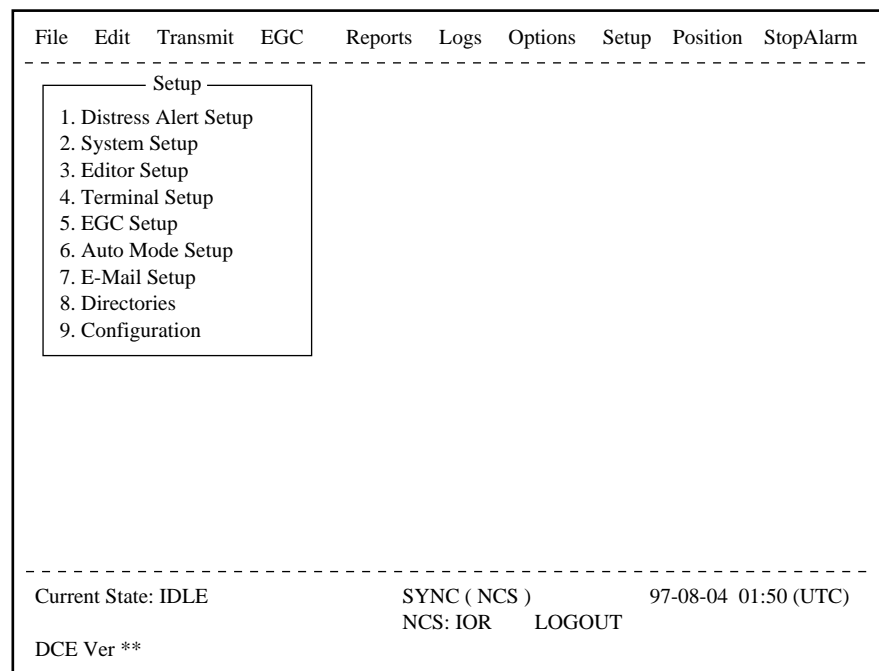

*Figure 2-1 Setup menu*

Menu Items which cannot be set on 2nd DTE (Sub DTE ) are shown in gray.

## System setup

The System Setup menu provides for input of date, time, operating mode, and port function.

1. Press [F8] to select the Setup menu.

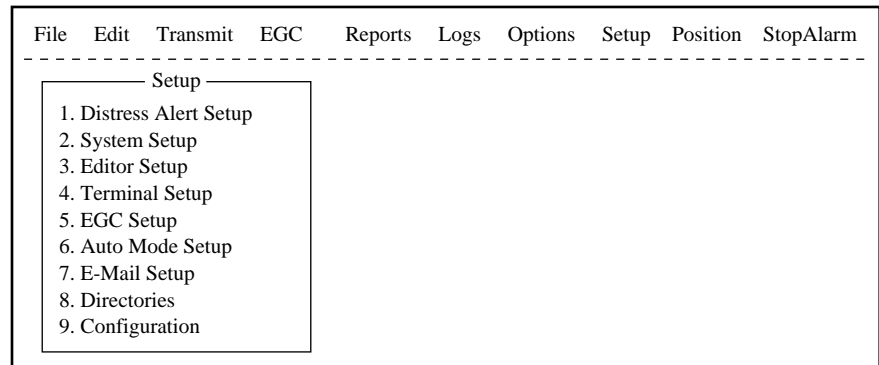

Figure 2-4 Setup menu

2. Press [2] to display the System Setup screen.

**Note:** *If the communication unit is off or its interconnection cable has loosened or is damaged, “No response from communication unit.” appears.*

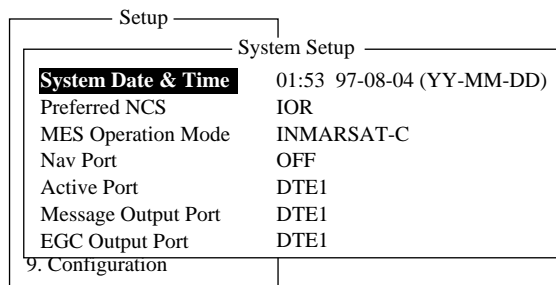

Figure 2-5 System setup menu

3. Press [Enter] to open the date window.

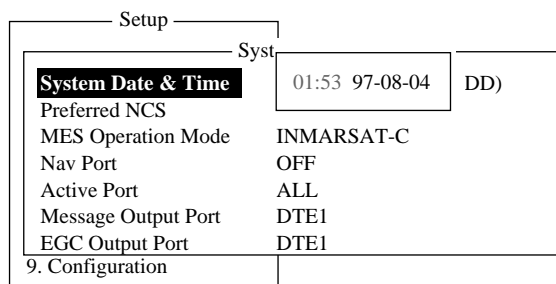

Figure 2-6 System setup menu, system date & time

4. Enter the date.
5. Press [Enter] to close the window.
6. Press [↓] to advance the cursor to the Preferred NCS line.

**Note:** *Date cannot be entered in the FFA version.*

7. Press [Enter] to open the selection window.

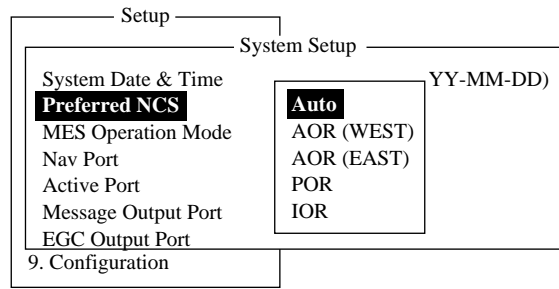

Figure 2-7 System setup menu, preferred NCS

8. Select appropriate NCS (Auto, AOR-West, AOR-East, POR or IOR) by arrow keys. The FELCOM 12 will search for that NCS signal each time it is turned on. The Auto setting searches all NCS signals to find the most suitable NCS; thus, scanning can take quite some time. (For reference, the coverage range of each satellite is shown in the figure on page 8.)

If you want to change the NCS channel temporarily, refer to “Selecting NCS channel” on page 7-4.

9. Press [Enter] to close the selection window.

10. Press [ ↓ ] to advance the cursor to the MES Operation Mode line.

11. Press [Enter] to open the selection window.

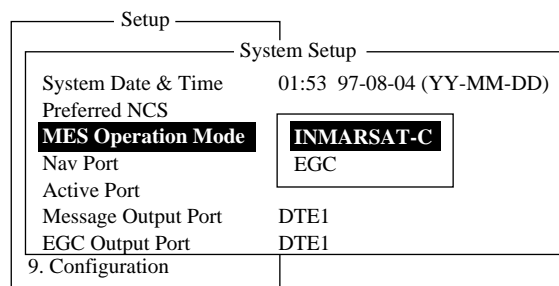

Figure 2-8 System setup menu, MES operation mode

12. Select operating mode, either Inmarsat C or EGC. The Inmarsat C setting provides telex communications and operates as an EGC receiver when not transmitting or receiving. The EGC setting enables EGC-only receiver operation. In this case EGC RECEIVER appears in reverse indication at the bottom of the screen.

13. Press [Enter] to close the selection window.

14. Press [ ↓ ] to advance the cursor to the Nav Port line.

**Note:** *The MES Operation Mode in the FFA version cannot be set to other than “Inmarsat C.”*

15. Press [Enter] to open the selection window.

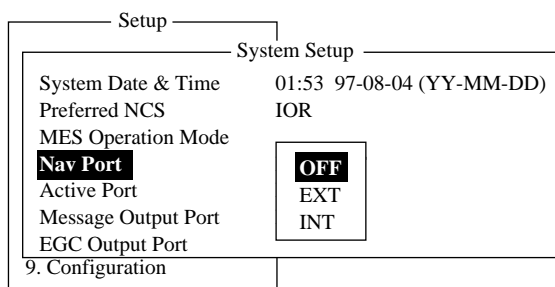

Figure 2-9 System setup menu, nav port

16. Select the navigation device which is interfaced to the FELCOM 12.

**OFF:** No connection

**EXT:** Select this setting when external navigation device is connected. The FELCOM 12 automatically selects ship's position information in the order of GPS, LC, and DECCA.

**INT:** Internal GPS board provides position data.

**Note:** The Nav Port setting in the FFA version cannot be set to other "INT."

**Note:** If there is no navigation equipment connection (Nav Port setting is "OFF"), you should input dead reckoning position in the Position menu. Refer to page 2-26.

17. Press [Enter] to close the selection window.

18. Press [ ↓ ] to advance the cursor to the Active Port line.

19. Press [Enter] to open the selection window.

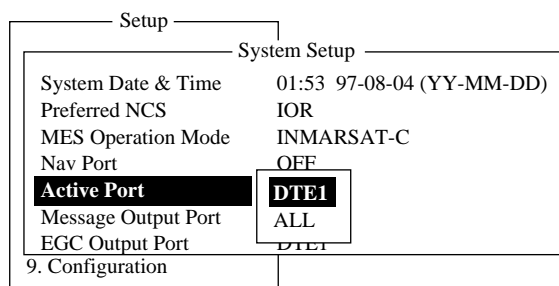

Figure 2-10 System setup menu, active port

20. Select active port (DTE); "DTE1" or "ALL".

**DTE1:** Only DTE1 is active.

**ALL:** DTE1, DTE2 and PC/DATA are active.

21. Press [Enter] to close the selection window.

22. Press [ ↓ ] to send the cursor to the Message Output Port line.

23. Press [Enter] to open the selection window.

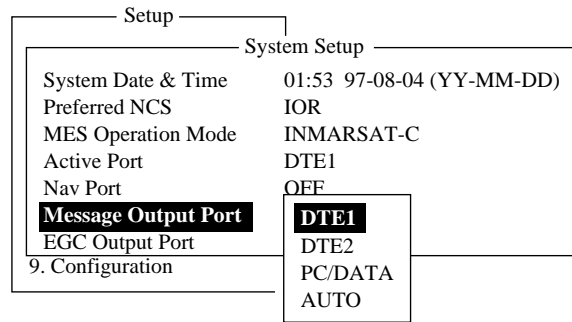

Figure 2-11 System setup menu, message output port

24. Select the DTE where you want to store receive messages.

- DTE1:** All receive messages are routed to the main DTE (connected to DTE1 on the communication unit) regardless of sub address.
- DTE2:** All receive messages are routed to the 2nd DTE (connected to DTE2 on the communication unit) regardless of sub address.
- PC/DATA:** All receive messages are routed to the PC/DATA (connected to PC/DATA on the communication unit) regardless of sub address (not used).
- AUTO:** Select to route messages with sub address 000 to the main DTE, and messages with the sub address of the 2nd DTE to the 2nd DTE. All other messages are routed to the main DTE.

**Note:** Do not select DTE2 or Auto when there is no DTE connected to the DTE2 port; messages cannot be read from the communications unit.

25. Press [Enter] to close the selection window.

26. Press [ ↓ ] to advance the cursor to the EGC Output Port line.

27. Press [Enter] to open the selection window.

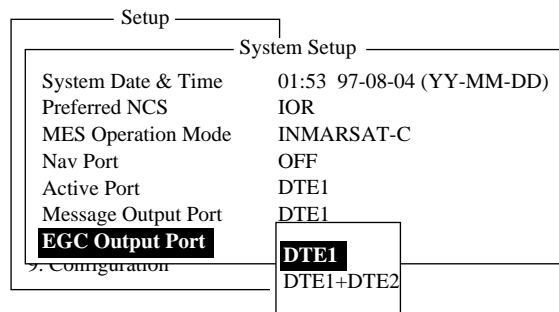

Figure 2-12 System setup menu, EGC output port

28. Select the DTE where you want to store receive EGC messages; DTE1, DTE2 or PC/DATA.

29. Press [Enter] to close the selection window.

30. Press [Esc] to open the update window.

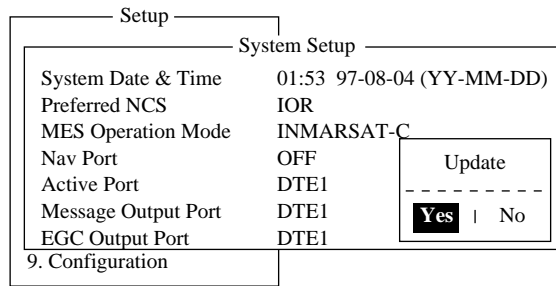

Figure 2-13 System setup menu, update

31. Press [Enter] to select “Yes”.

32. Press [Esc] to register all system setup settings and return to the standby display.

## Terminal Setup

Terminal Setup menu provide for date display format,screen saver and display mode.

1. Press [F8] to select the Setup menu.
2. Press [4] to display the Terminal Setup screen.

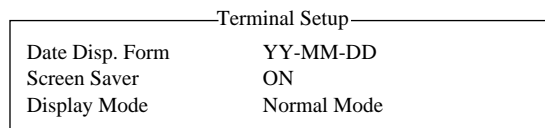

Figure 2-14 Terminal Set up menu.

3. Press [Enter] to open the selection window.
4. Select date display format “YY-MM-DD(year-month-day)”, “MMM-DD-YY(month-day-year)” or “DD-MMM-YY(day - month -year)”.
5. Press [Enter] to close the selection window.
6. Press [ ↓ ] to advance the cursor to the Screen Saver line.
7. Press [Enter] to open the selection window.
8. Select “ON” or “OFF”.
9. Press [Enter] to close the selection window.
10. Press [ ↓ ] to advance the cursor to the Display Mode line.
11. Press [Enter] to open the selection window.



12. Select “Normal Mode” or “Reverse Mode”.  
Normal Mode displays black characters on white background.  
Reverse Mode displays white characters on black background.
13. Press [Enter] to close the selection window.
14. Press [Esc] to return to the standby display.

## Login and Logout

Each time the DTE and communication unit are turned on register your vessel with the Inmarsat C system, to enable communications between your vessel and LES. This is called login. The first time you login you must do it manually; thereafter the NCS does it for you automatically, even when you move to another ocean region.

Note that the distress alert can be transmitted and EGC messages received regardless of whether you are logged in or not.

**If you will not be using the FELCOM 12 for a prolonged period you should logout from the Inmarsat C system, before turning off the power to the communication unit.** The Inmarsat C system will then register you as inactive, notifying anyone trying to call you that you are currently unavailable. If you do not log out before turning off the power, the LES may attempt to send a message to you. **It may charge your correspondent, even if you never receive the message.**

**Note:** *The communication unit should be idle (“Current State: IDLE” appears at the bottom of the screen) to login and logout.*

**Note:** *When the FFA version is active, vessel is automatically logged in when the power is turned on.*

## Login

1. Confirm that “SYNC (NCS)” appears at the bottom of the screen.
2. Press [F7] to display the Options menu.

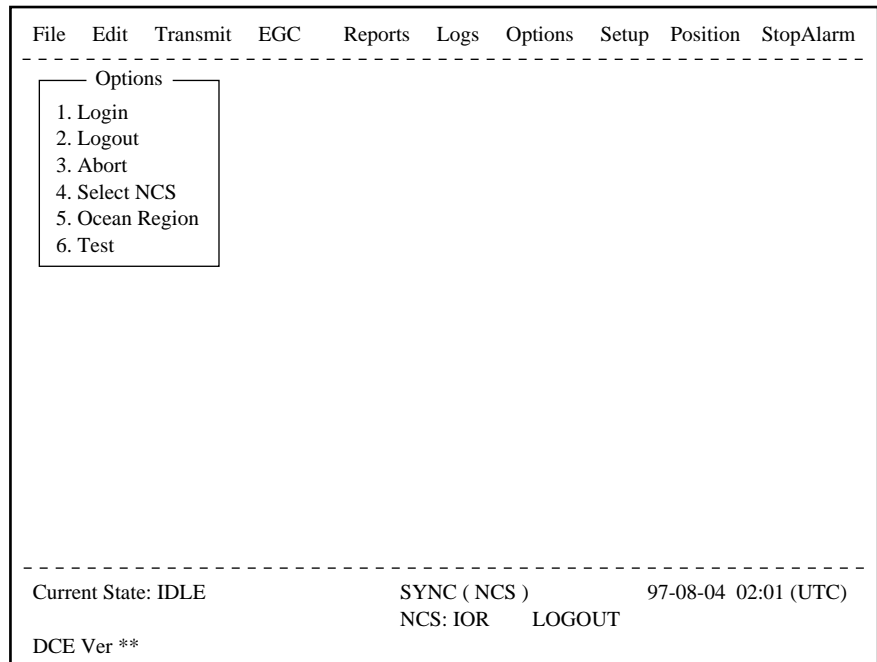

Figure 2-15 Options menu

3. Press [1] to display the Login screen.

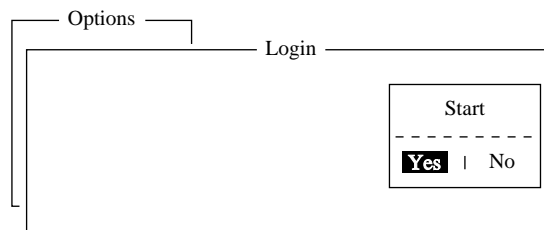

Figure 2-16 Login screen

**Note:** *The communication unit must be idle to login. When it is not idle, “Communication Unit is not IDLE now. Cannot start login.” appears. Press any key to return to the standby display. Wait until the communication unit becomes idle.*

4. Press [Enter] to start login.

5. LOGIN begins and the screen should now look something like Figure 2-17. The indication LOGIN appears in blinking reverse video.

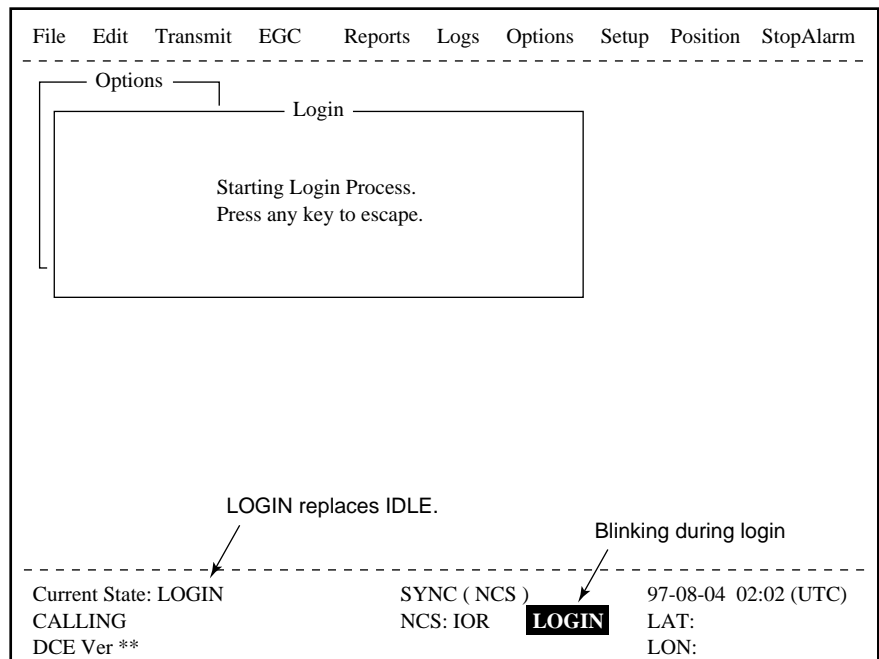

Figure 2-17 Appearance of display screen during login

6. When login is completed, “Successful login” appears. The communication unit goes into Idle state, LOGIN stops blinking and the ocean region you logged in with appears on the screen.
7. Press any key to return to the standby display.

## Logout

1. Press [F7] to display the Options menu.
2. Press [2] to display the logout screen.

**Note:** *The communication unit must be idle to logout. When it is not idle, “Communication Unit is not IDLE now. Cannot start logout.” appears. Press any key to return to the standby display. Wait until the communication unit becomes idle.*

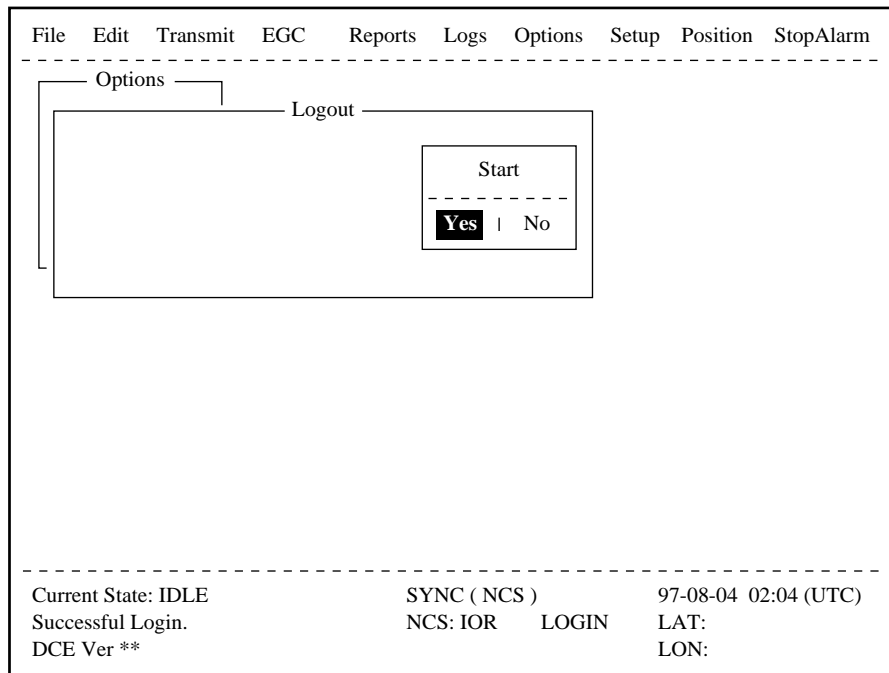

Figure 2-18 Options menu, logout screen

3. Press [Enter] to start logout. Logout begins and the screen now looks something like Figure 2-19.

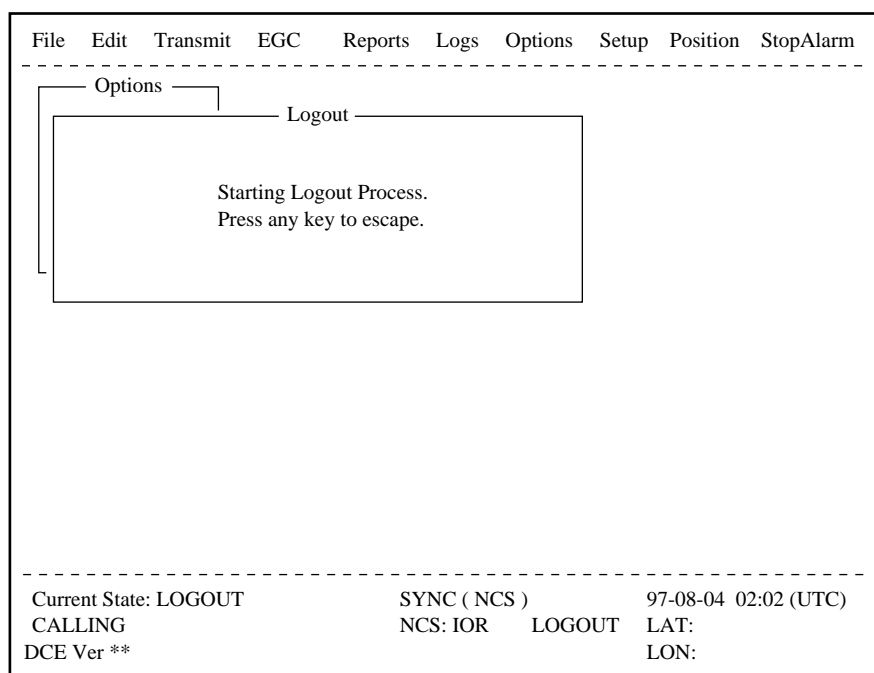

Figure 2-19 Appearance of display screen during logout

4. When logout is completed, “Successful logout” appears. The Current State returns to IDLE.
5. Now you can turn off the power of the FELCOM 12.

**Note:** In the FFA version, the display shows the message “INF: Logout request accepted. please wait.”

# EGC Settings

## What is the EGC (Enhanced Group Call) service?

The EGC service enables EGC information providers to send SafetyNET™ or FleetNET™ messages via a LES to select groups of ships, or to all ships within a defined geographical area.

To send an EGC message, the information provider prepares the message, and then accesses the Country of international telex network to send the message to the LES. The LES processes and forwards it to the NCS for the ocean region designated by the provider. Then, NCS broadcasts the message throughout the ocean region.

Although all MESs can receive the EGC message, the message is accepted only by those receivers that have been pre-programmed for the area or group conditions contained in the message. All other EGC receivers reject the message.

Two EGC services are available:

### 1) SafetyNET™

This provides a means for information providers to distribute Maritime Safety Information (MSI) from shore-to-ship. Authorized information providers include:

- a. Hydrographic Offices, for navigational warnings
- b. National Weather Services, for meteorological warnings and forecasts
- c. Rescue Co-ordination Center, for shore-to-ship distress alerts and other urgent information
- d. International Ice Patrol, for North Atlantic ice hazards

### 2) FleetNET™

This service allows authorized information providers such as commercial subscription services, shipping companies and governments, which have registered with a LES that supports FleetNET™, to broadcast messages to selected group of MESs. Typical applications of FleetNET™ are:

- a. Fleet or company broadcasts
- b. News broadcasts
- c. Commercial weather services
- d. Market quotations
- e. Government broadcasts to all vessels on a country's registration

## EGC setup

The FELCOM 12 receives EGC messages directed to its present position and Navarea without further programming. The EGC Setup screen lets you select additional areas for which you wish to receive messages and also the Navtex station and type of message for Coastal Warning (NAVTEX Re-broadcast).

1. Press [F8] to display the Setup menu.

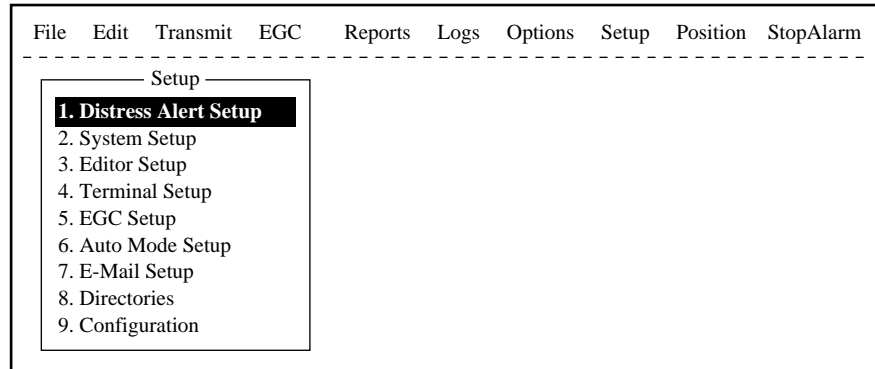

Figure 2-20 Setup menu

2. Press [5] to display the EGC Setup screen.

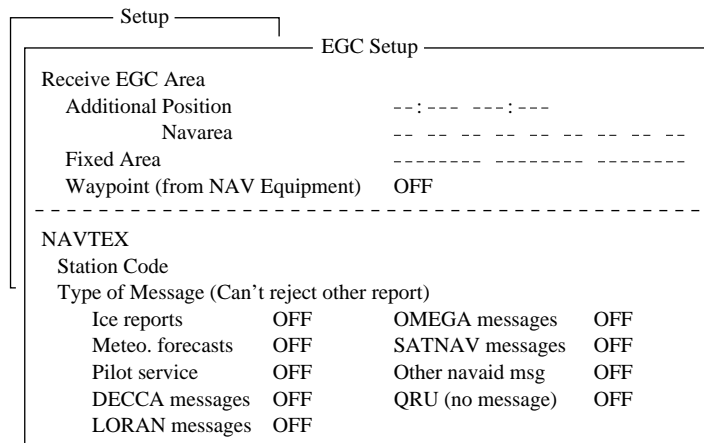

Figure 2-21 EGC setup screen

The cursor is on the Additional Position line, where you can enter L/L position of an ocean region you want to receive broadcasts for.

3. Press [Enter] to open the additional position window.
4. Enter positions as follows.
  - a) Enter latitude.
  - b) Enter [N] or [S].
  - c) Enter longitude.
  - d) Enter [E] or [W].

5. Press [Enter] to close the position window.
6. Press [ ↓ ] to send the cursor to the Navarea line.
7. Press [Enter] to open the Navarea window.

Setup		EGC Setup	
Receive EGC Area			
Additional Position			
Navarea			-----
Fixed Area			
Waypoint (from NAV Equipment)			OFF
-----			
NAVTEX			
Station Code			
Type of Message (Can't reject other report)			
Ice reports	OFF	OMEGA messages	OFF
Meteo. forecasts	OFF	SATNAV messages	OFF
Pilot service	OFF	Other navaid msg	OFF
DECCA messages	OFF	QRU (no message)	OFF
LORAN messages	OFF		

Figure 2-22 EGC setup screen, Navarea window

8. Enter additional Navarea(s) (up to nine) for which you want to receive broadcasts. Figure 2-23 shows the Navareas of the world. Referring to the figure below for numeral and alphabet, enter additional Navareas (up to nine) for which you want to receive broadcasts.

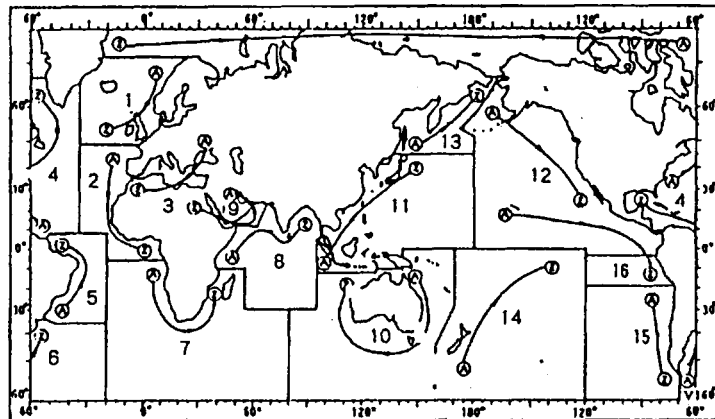

Figure 2-23 Navareas

9. Press [Enter] to close the Navarea window.
10. Press [ ↓ ] to send the cursor to Fixed Area.
11. This line is where you enter fixed areas (max. 3) for chart correction service. However, this service is not yet available; enter no data.
12. Press [ ↓ ] to send the cursor to the Waypoint line.

13. Press [Enter] to open the Waypoint window.

The screenshot shows the 'EGC Setup' screen. At the top, there are two labels: 'Setup' on the left and 'EGC Setup' on the right. The screen is divided into sections. The first section is 'Receive EGC Area', which includes 'Additional Position' (displaying '---: ---: ---: ---'), 'Navarea' (displaying '-----'), 'Fixed Area' (displaying '-----'), and 'Waypoint (from NAV Equipment)' (displaying 'ON' in a box). Below this is the 'NAVTEX' section, which includes 'Station Code' (displaying '-----') and 'Type of Message (Can't reject other report)'. The message types and their status are: Ice reports (OFF), OMEGA messages (OFF), Meteo. forecasts (OFF), SATNAV messages (OFF), Pilot service (OFF), Other navaid msg (OFF), DECCA messages (OFF), QRU (no message) (OFF), and LORAN messages (OFF).

Figure 2-24 EGC setup screen, waypoint

14. Select ON to receive broadcasts for the area of a destination waypoint selected on the navigation device.

15. Press [Enter] to close the Waypoint window.

16. Press [ ↓ ] to advance the cursor to the Station Code line.

17. Press [Enter] to open the Station Code window.

The screenshot shows the 'EGC Setup' screen. At the top, there are two labels: 'Setup' on the left and 'EGC Setup' on the right. The screen is divided into sections. The first section is 'Receive EGC Area', which includes 'Additional Position' (displaying '---: ---: ---: ---'), 'Navarea' (displaying '-----'), 'Fixed Area' (displaying '-----'), and 'Waypoint (from NAV Equipment)' (displaying 'OFF'). Below this is the 'NAVTEX' section, which includes 'Station Code' (displaying '-----' in a box) and 'Type of Message'. The message types and their status are: Ice reports (OFF), OMEGA messages (OFF), Meteo. forecasts (OFF), SATNAV messages (OFF), Pilot service (OFF), Other navaid msg (OFF), DECCA messages (OFF), QRU (no message) (OFF), and LORAN messages (OFF).

Figure 2-25 EGC setup, station code

18. Enter the navtex station code (A-Z) of the navarea. For details about navtex stations, consult the operator's manual of the navtex receiver.

19. Press [Enter] to close the Station Code window.

20. Using the up/down arrow keys enable/disable reception of NAVTEX broadcasts and press [Enter].

Note that navtex message types “Coastal navigational information”, “Meteorological warning” and “Search and rescue alert” (they do not appear on the display) cannot be deleted since they are considered essential to navigation.



21. Press [Esc] to open the update window.

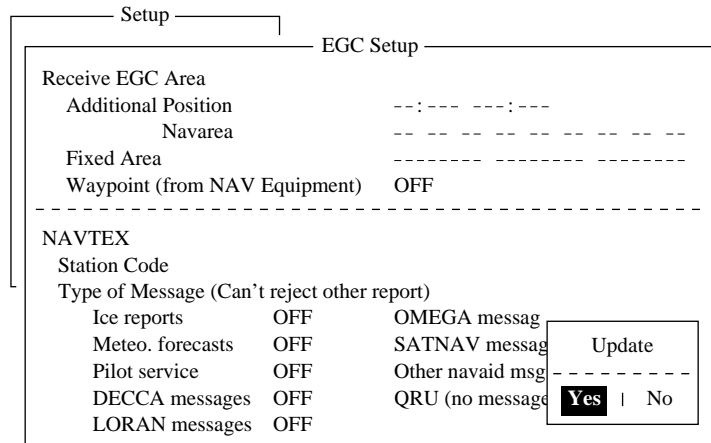

Figure 2-26 EGC setup screen, update window

22. Press [Enter] to select “Yes” and register all EGC settings.

23. Press [Esc] to return to the standby display.

## Programming EGC channels

The EGC Channel List in the Setup menu stores EGC channels.

There are currently four EGC channels, one for each satellite. These four channels are pre-programmed into the unit and marked in the EGC Channel List with asterisks. When more EGC channels become available you can add them to the list.

1. Press [F8] to display the Setup menu.
2. Press [9] to display the Configuration menu.
3. Press [3] to display the EGC Channel List.

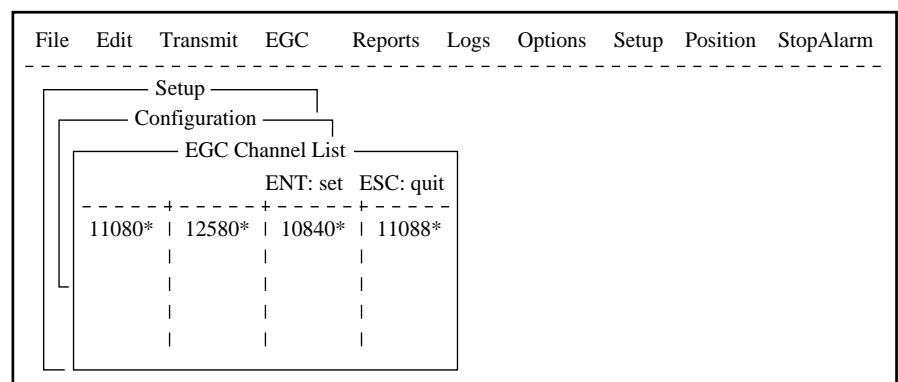

Figure 2-27 EGC channel list

4. Current EGC channels are marked with an asterisk. These channels cannot be changed.
5. With the arrow keys place the cursor where there is no data entered.

- Press [Enter] to open the text window.

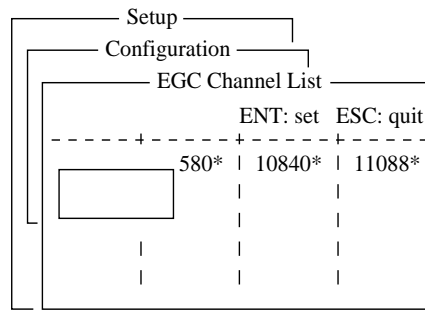

Figure 2-28 EGC channel list, cursor displayed

- Enter EGC channel frequency code.
- Press [Enter] to close the text window.
- Press [Esc] to open the update window.

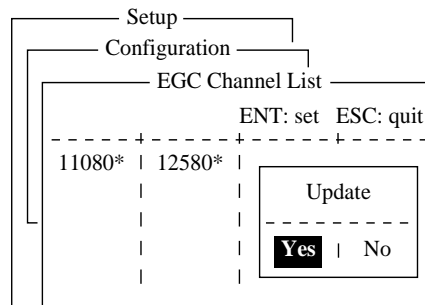

Figure 2-29 EGC channel list, update window

- Select “Yes” and press [Enter] to register input.

**Note:** The EGC channel frequency code range is 8000-14000. Any frequency code entered which is out of this range will display "Input Error: Channel No." Clear the error message by pressing the [Esc] key. Place the cursor at the invalid frequency. Then, press the [Enter] key and enter correct frequency.

## Programming NCS Channels

This section shows you how to add NCS channels to the NCS Channel List. Up to 19 channels can be listed per each ocean region. Currently, there are four NCS channels, and they are marked with asterisks in the list.

Below is the procedure for adding NCS channels, when they become available.

- Press [F8] to display the Setup menu.
- Press [9] to display the Configuration menu.
- Press [4] to display the NCS Channel List.

NCS Channel List								
ENT: set ESC: quit								
No	AOR (WEST)		AOR (EAST)		POR		IOR	
	ID	FREQ	ID	FREQ	ID	FREQ	ID	FREQ
1	044	11080*	144	12580*	244	12580*	344	10840*
2	0		1		2		3	
3	0		1		2		3	
4	0		1		2		3	
5	0		1		2		3	
6	0		1		2		3	
7	0		1		2		3	
8	0		1		2		3	

Figure 2-30 NCS channel list

4. Current NCS common channels are marked with an asterisk. These channels cannot be changed.
5. Place the cursor where there is no data entered.
6. Press [Enter] to open the text window.
7. Enter NCS channel ID number.
8. Press [Enter] to close the text window.
9. With [→] advance the cursor to the frequency column.
10. Press [Enter] to open the text window.
11. Enter NCS channel frequency code.
12. Press [Enter] to close the text window.
13. Press [Esc] to open the update window.

NCS Channel List								
ENT: set ESC: quit								
No	AOR (WEST)		AOR (EAST)		POR		IOR	
	ID	FREQ	ID	FREQ	ID	FREQ	ID	FREQ
1	044	11080*	144	12580*	244	12580*	344	10840*
2	0		1		2		3	
3	0		1		2		3	
4	0		1		2		3	
5	0		1		2		3	
6	0		1		2		3	
7	0		1		2		3	
8	0		1		2		3	

Update

Yes |  No

Figure 2-31 NCS channel list, update window

14. Press [Enter] to register input.

**Note:** The ID number range is 45-63 and the frequency code range is 8000-14000. Any ID or frequency entered which is out of those range will display "Input Error: NCS ID" (for invalid ID) or "Input Error: Channel No." (For invalid frequency). Clear the error message by pressing the [Esc] key. Place the cursor at the invalid ID or frequency code. Then, press the [Enter] key and enter correct ID or frequency.

15. Press [Esc].

# LES List Operations

The LES List provides for storage of 44 LES names per ocean region. When the LES table is opened on the Send menu, LES names entered in this LES List appear along with their IDs. See page 2-21.

## Programming the LES list

1. Press [F8] to display the Setup menu.

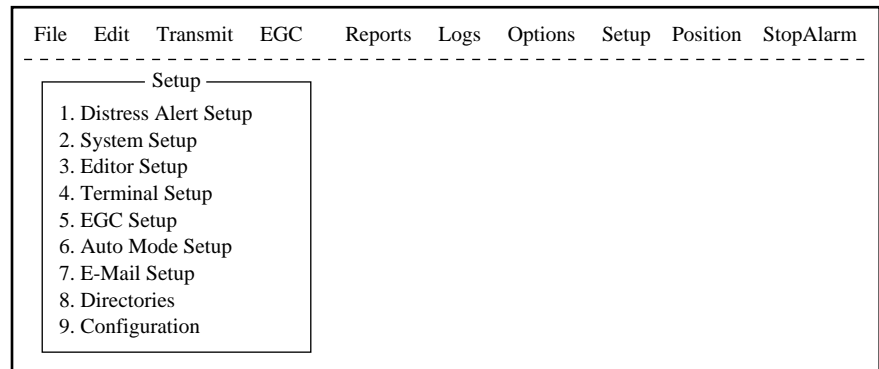

Figure 2-32 Setup menu

2. Press [9] to display the Configuration menu.

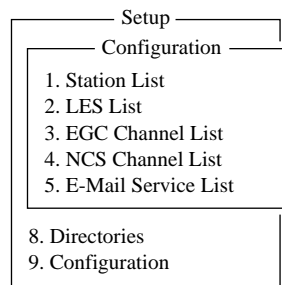

Figure 2-33 Configuration menu

3. Press [2] to display the LES List.

No	AOR (WEST) Name	AOR (EAST) Name	POR Name	IOR Name
1	SOUTHBURY	SOUTHBURY	SANTA PAULA	
2	GOONHILLY	GOONHILLY		
3			YAMAGUCHI	YAMAGUCHI
4				EIK
5		FUCINO		THERMOPYLAE
6				ARVI
7				
8			KUMSAN	KUMSAN

Figure 2-34 LES list

4. With the arrow keys place the cursor where no data is entered.
5. Press [Enter].

No	AOR (WEST) Name	AOR (EAST) Name	POR Name	IOR Name
1	SOUTHBURY			
2	GOONHILLY			
3				YAMAGUCHI
4				EIK
5				THERMOPYAE
6				ARVI
7				
8			KUMSAN	KUMSAN

Figure 2-35 LES list, LES entry window

6. Press [Enter] to open the text window.

Name :	<input type="text"/>
ID :	<input type="text"/>
Remarks :	<input type="text"/>
-----	
Erase the Name to delete this LES.	

Figure 2-36 LES list, text window

7. Enter LES name (maximum 15 characters).
8. Press [Enter].
9. Press [↓] to advance the cursor to the ID line.
10. Press [Enter].
11. Enter LES ID. The table on page 2-21 shows all current LES IDs.
12. Press [Enter].
13. Press [↓] to send the cursor to the Remarks line.
14. If desired, enter remarks (up to 20 characters).
15. Press [Esc] to register LES.
16. To return to the standby display, press [Esc] three times.

## Deleting and changing the LES list

1. Press [F8], [9] and [2] to display the LES list.
2. Select the LES you want to edit.
3. Press [Enter].  
The cursor should be on the Name line.

```
Name : Yamaguchi
ID   : 303
Remarks : KDD Japan.....
-----
Erase the Name to delete this CES.
```

Figure 2-37 LES selected from LES list

4. Press [Enter] again to open the window for name entry.
5. To delete/change the LES name, press [Backspace] to erase name and then press [Enter].
6. To edit an entry, place the cursor on the item you want to edit, press [Enter], delete with the [Backspace] key, then enter new data.
7. Press [Esc] to save changes.
8. To return to the standby display, press [Esc] twice.

## Printing the LES list

1. Press [F8], [9] and [2] to display the LES list.
2. While pressing and holding down [Ctrl], press [P] to print the LES list.

```
-----
LES List ( Printed at 97-08-04 02:33 )

+++++ AOR (WEST) +++++
No. Name      LES ID   Remarks
01  SOUTHBURY  001     USA
02  GOONHILLY  002     UK (NCS, ID044)
12  STATION12  012     NETHERLANDS

+++++ AOR (EAST) +++++
No. Name      LES ID   Remarks
01  SOUTHBURY  101     USA
```

Figure 2-38 Sample LES list printout

3. To return to the standby display, press [Esc] three times.

*Table 2-1 LES IDs*

<b>LES menu</b>	<b>AOR West</b>	<b>AOR East</b>	<b>IOR</b>	<b>POR</b>
Perth			322	222
Goonhilly	002	102	302	
NETELY/BY/TELEN				202
Aussaquel		121	321	
Burum	022			
Blaavand		131		
Eik/Telenor	004	104	304	
Sentosa			328	210
Tangua	014	114		
Odessa		107	307	
Maadi		103		
Arvi			306	
Umm al Aish		106		
Fucino		105	335	
Thermopylae		120	305	
Jeddah			315	
Yamaguchi	003	103	303	203
Santa Paula				201
Sintra		118		
Southbury	001	101		
Ata		110	310	
Kumsan			308	208
Raisting		115	333	
Beijing			311	211
Psary		116	316	
Boumehen			314	
Nonthaburi			319	
Station 12	012	112	312	212
Station 12/Telstra		122		

# Station List Operations

## Programming the station list

The FELCOM 12 provides an “address book” for programming 64 station IDs.

1. Press [F8] to display the Setup menu.
2. Press [9] to display the Configuration menu.
3. Press [1] to display the Station List.

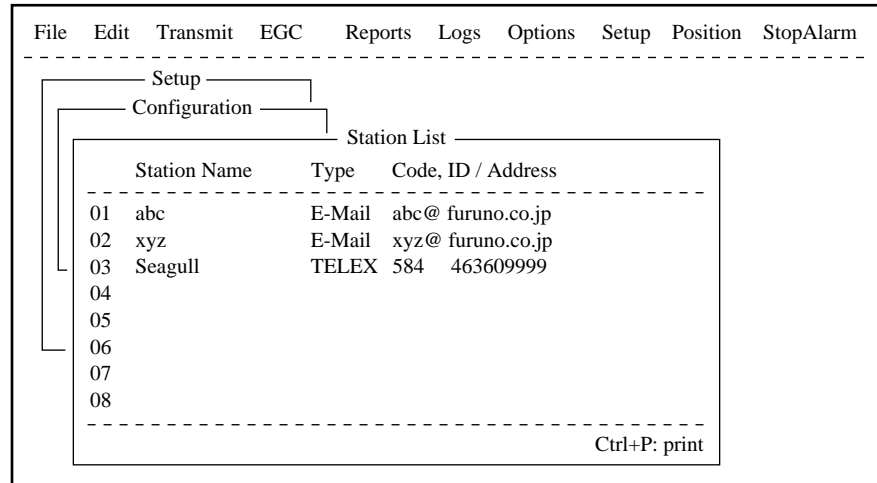

Figure 2-39 Sample station list

4. Operate [ ↓ ] to place the cursor on a blank line.
5. Press [Enter].

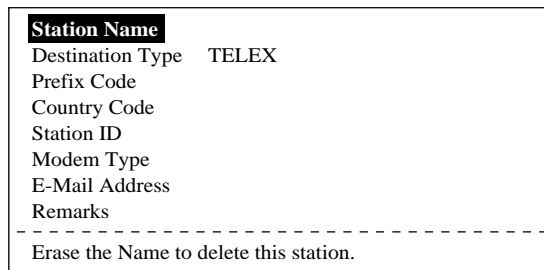

Figure 2-40 Entering a station

6. Press [Enter] to open the window for station name entry.
7. Enter name of station, using up to 15 characters.
8. Press [Enter] to close the window.
9. Press [ ↓ ] to send the cursor to the Destination Type line.



10. Press [Enter] to open the destination type window.

TELEX
FAX
E-Mail
CSDN
PSDN
X400
DNID
SPEC
TELEX (Prefixed)
FAX (Prefixed)
PSDN (Prefixed)
X400 (Prefixed)
DNID (Prefixed)
SPEC (Prefixed)

Figure 3-41 Selection window for “destination type”

**TELEX:** Telex communication

**FAX:** Facsimile service  
- to an office facsimile machine

**E-Mail:** E-mail (electronic mail) Service

**CSDN:** Circuit Switched Data Network-not used.

**PSDN:** Packet Switched Data Network  
-to an office computer via a data network using X.25 standard.

**X400:** For future use

**DNID:** Data Network ID -not used.

**SPEC:** Ship-to shore requests for safety service, accessed by using special 2-digit codes (See Note 2 below.)

**Note 1:** When FAX is selected, select “T30 (FAX)” in the “Modem Type” selection display. For further details, refer to page 4-2.

**Note 2:** When SPEC is selected on the Type line, the Country Code line disappears. Enter two-digit codes on the Station ID line. Refer to page 4-18 for further details.

11. Set up according to Destination Type selection. The steps which follow show how to set up for TELEX (Prefixed).

12. Press [Enter] to close the destination type window.

13. [ ↓ ] to advance the cursor to the Prefix Code line for prefixed.

14. Press [Enter] to open the prefix code window.

15. Key in prefix code in two digits.

Note that some services may not be available depending on LES.

Prefix Code	Function
11	Operator's Assistance
12	Dial Guide
33	Technical Assistance
91	Automatic Telex Test
⋮	⋮

16. Press [Enter] to close the prefix code window.
17. Press [ ↓ ] to advance the cursor to the Country Code line for TELEX, FAX, PSDN.
18. For ship-to-shore telex, enter international telex country code; ship-to-ship telex, enter ocean region. A list of international telex country codes begins on page A-1 in the Appendix.

Ocean Region

AOR-East: 581  
 POR: 582  
 IOR: 583  
 AOR-West: 584

19. Press [Enter] to close the window.
20. Press [ ↓ ] to send the cursor to the Station ID line.
21. Press [Enter] to open the window for station ID entry.
22. Enter telex subscriber number (for land) or MES Inmarsat Mobile Number (for ship).  
 Up to 15 characters, including space, can be entered.
23. Press [Enter] to close the window.
24. Press [ ↓ ] to advance the cursor to the Remarks line.
25. Press [Enter] to open the window for remarks entry.
26. If desired, enter remarks (up to 20 characters).
27. Press [Enter] to close the window.
28. To return to the standby display, press [Esc] three times.

## Editing the station list

1. Press [F8], [9] and [1] to display the Station List.

Station Name	Type	Code, ID / Address
01 abc	E-Mail	abc@ furuno.co.jp
02 xyz	E-Mail	xyz@ furuno.co.jp
03 Seagull	TELEX	584 463609999
04		
05		
06		
07		
08		

Figure 2-42 Station list

2. Press [ ↓ ] and [Enter] to select the station you want to edit.
3. Press [Enter] to open the station name window.
4. To delete a station, press [Backspace] to erase station name, and then press [Enter].
5. To edit a station name, place the cursor on the character you want to edit. Press [Backspace] to erase that character, then enter correct character.
6. Press [Enter] to save changes.
7. If necessary, select other item, edit it and press [Enter].
8. To return to the standby display, press [Esc] four times.

## Printing the station list

1. Press [F8], [9] and [1] to display the Station List.
2. While pressing and holding down [Ctrl], press [P].

No.	Name	Type	Dest, ID, Modem / Address	Remarks
01	abc	E-Mail	abc@ furuno.co.jp	
02	xyz	E-Mail	xyz@ furuno.co.jp	
03	Seagull	TELEX	584 463609999	

Figure 2-43 Sample station list printout

3. To return to the standby display, press [Esc] three times.

# Entering Own Ship's Position

When there is no navigation device connected, select OFF on the Nav Port line in the System Setup menu, as explained on page 2-4, and enter ship's position manually as follows:

1. Press [F9] to display the Position menu.

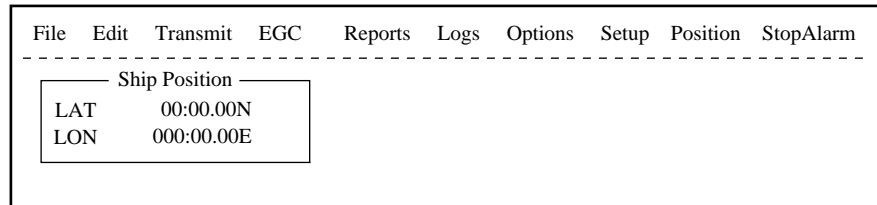

Figure 2-44 Ship position

2. Press [Enter] to open the window for latitude entry.

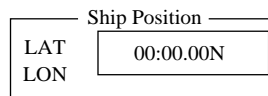

Figure 2-45 Ship position, window for entering position

3. Enter latitude and [N] or [S].
4. Press [Enter] to close the window.
5. Press [↓] to send the cursor to the LON line.
6. Press [Enter] to open the window for longitude entry.

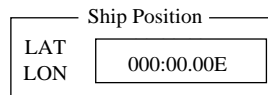

Figure 2-46 Ship position

7. Enter longitude and [E] or [W].
8. Press [Enter] to close the window.
9. Press [Esc] to open the update window.

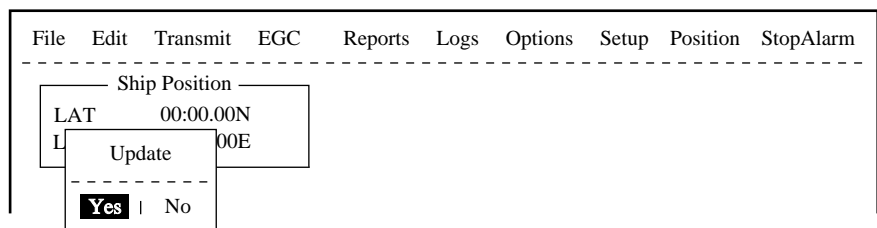

Figure 2-47 Ship position, update

10. Press [Enter] to close Ship Position menu.

This position data is also entered on the "Update Distress Alert" screen. (Refer to page 6-1.)

# Setting Directories

You can designate the directory where to save incoming and outgoing messages as follows:

1. Press [F8] to display the Setup menu.
2. Press [8] to display the Directories menu.

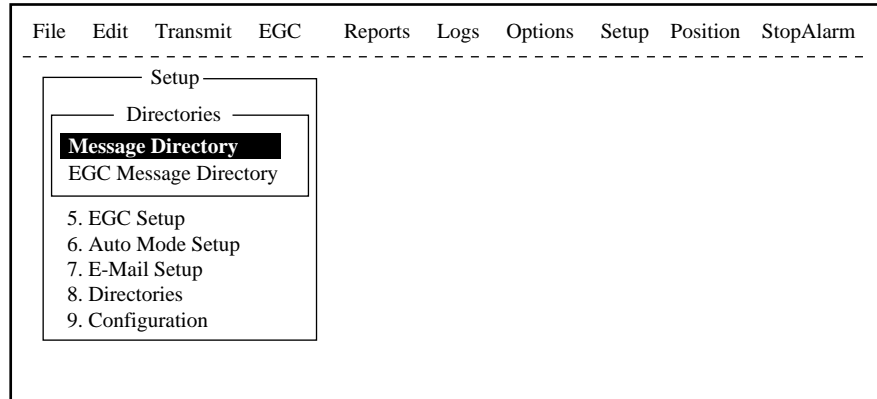

Figure 2-48 Setup menu, directories

3. Press [Enter] to select “Message Directory”.  
Message Directory appears in the command line.

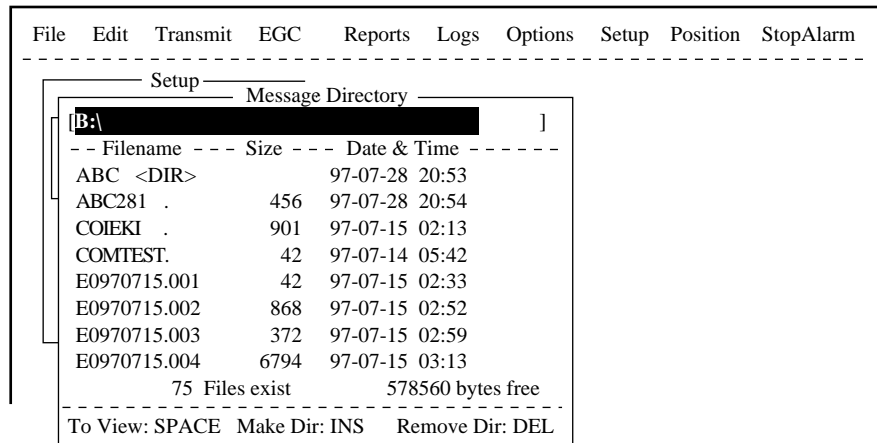

Figure 2-49 Setup menu, directories, message directory

4. Press [ ↓ ] to select a directory name.
5. Press [Insert] to make a new directory name.
6. Type a new directory name (for example, MESSAGE).
7. Press [Enter].
8. Press [ ↑ ] .
9. Press [Enter] to select directory name.
10. Press [Esc] twice to return to standby.

# E-mail Service List

The E-mail service list provides for E-mail set up. Currently there are four service stations which handle E-mail. The procedure below describes how to add service stations to the list.

1. Press [F8] to display the Setup menu.
2. Press [9] to display the Configuration menu.

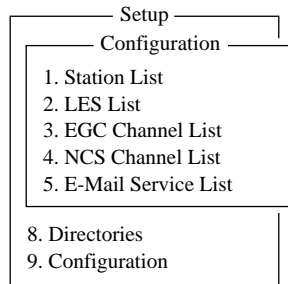

Figure 2-50 Setup menu, configuration

3. Press [5] to display the E-mail Service List.

	Station Name	AOR.W	AORE	POR	IOR
01	Comsat	001	101	201	321
02	PTT Telecom	012	112	212	312
03	British Telecom	002	102	202	302
04	Stratos	022	122	222	322
05	Telstra	022	122	222	322
06	EIK	004	104		304
07					
08					

Figure 2-51 Setup menu, configuration, E-Mail Service List

4. Select blank space in Station Name column and press [Enter]. E-mail setup display appears.

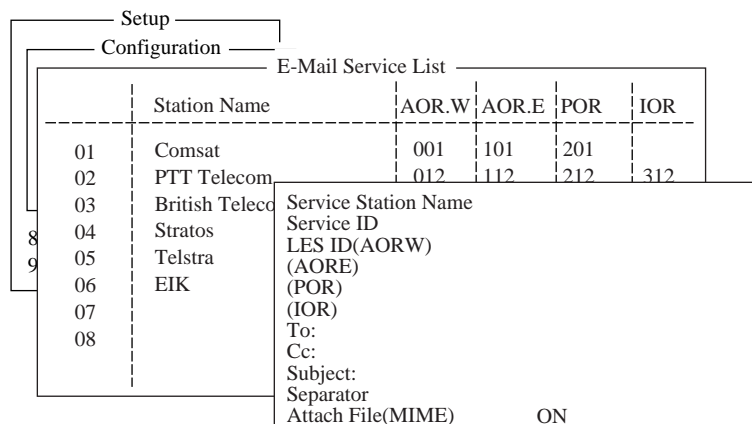

Figure 2-52 E-mail setup

5. Press [Enter] to open the window for service station name entry.

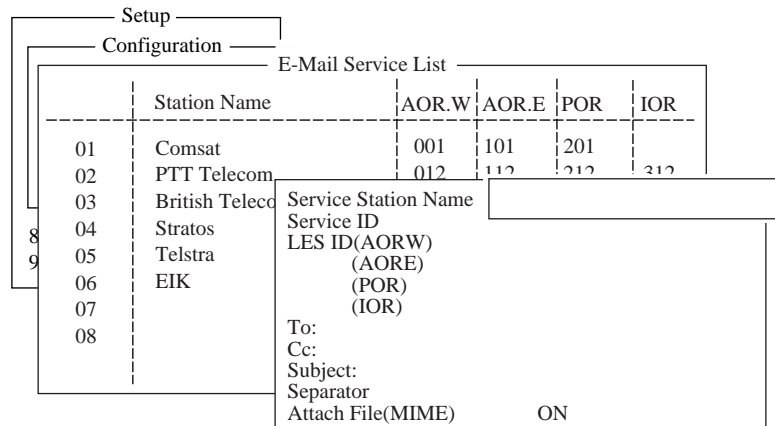

Figure 2-53 Service station list

6. Type service station name.
7. Press [Enter] to close the window.
8. Press [ ↓ ] to place the cursor on the Service ID line.
9. Press [Enter] to open the window for service ID entry.
10. Type Service ID.  
Service ID is station address .
11. Press [Enter] to close the window.
12. Press [ ↓ ] to place the cursor on the LES ID line.
13. Press [Enter] to open the window for LES ID entry.
14. Type LES ID of AOR-W.
15. Press [Enter] to close the window.
16. Follow steps 12 thru step 15 for AOR-E, POR and IOR.
17. Press [ ↓ ] to place the cursor on the “To:” line.
18. Press [Enter] to open the window for “to” header entry.
19. Type proper “To” header (for example, TO:, to+, etc.).
20. Press [Enter] to close the window for “cc” header entry.
21. Press [ ↓ ] to place the cursor on the “Cc:” line.
22. Press [Enter] to open the window for “cc” header entry.
23. Type proper “Cc” header (for example, CC:, cc+, etc.).
24. Press [Enter] to close the window for “subject” header entry.
25. Press [ ↓ ] to place the cursor on the “Subject:” line.
26. Press [Enter] to open the window for “subject” header entry.
27. Type proper “Subject” header (for example, Subject:, subject+, etc.).
28. Press [Enter] to close the window for separator entry.

29. Press [ ↓ ] to place the cursor on the “Separator” line.
30. Press [Enter] to open the window for separator entry.
31. Type proper Separator (for example, blank space, STX:, etc.).
32. Press [Enter] to close the window.
33. Press [ ↓ ] to place the cursor on the “Attach File (MIME)” line.
34. Press [Enter] to open the selection window.
35. Select “ON” or “OFF”.
36. Press [Enter] to close the selection window.
37. Press [Esc] three times to return to the standby display.

## E-mail Setup

Select the LES where to forward E-mail. Also, you will need to register with the LES to get E-mail services.

1. Press [F8] to display the Setup menu.
2. Press [7] to display E-mail Setup screen.

Setup					
E-Mail Setup					
	Station Name	AOR.W	AOR.E	POR	IOR
01	Comsat	001	101	201	

6. Auto Mode Setup  
 7. E-Mail Setup  
 8. Directories  
 9. Configuration

Figure 2-54 E-mail Set up display

3. Press [Enter] to open the selection window.

Setup					
E-Mail Setup					
	Station Name	AOR.W	AOR.E	POR	IOR
01	Comsat	001	101	201	321
02	PTT Telecom	012	112	212	312
03	British Telecom	002	102	202	302
04	Stratos	022	122	222	322
05	Telstra	022	122	222	322
06	EIK	004	104		304
07					
08					

Figure 2-55 E-mail Operating LES

4. Selecter the LES where to forward E-mail.



5. Press [Enter] to the update window.

The screenshot shows a terminal window with a menu structure. At the top, 'Setup' is indicated with a bracket. Below it, 'E-Mail Setup' is also indicated with a bracket. The main menu is a table with columns: Station Name, AOR.W, AOR.E, POR, and IOR. The rows are numbered 01 to 08. An 'Update' window is overlaid on the table, containing the text 'Update' and a highlighted 'Yes' button followed by 'No'.

	Station Name	AOR.W	AOR.E	POR	IOR
01	Comsat	001	101	201	
02	PTT Telecom	012	112	212	312
03	British Telecom	002	102	210	
04	Stratos	022	102		202
05	Telstra				
06	EIK				
07					
08					

Update  
Yes | No

Figure 2-56 update window

6. Press Enter again.

7. Press ESC to return the stand by display.

This page is intentionally left blank.

# FILE OPERATIONS

This chapter describes how to prepare, edit, save and print files (messages).

## Preparing a Message

There are two types of files: routine and confidential.

Messages can be assigned a file name and saved to a floppy disk for later use. A message may contain maximum 124×254 characters (32 Kbytes).

### Preparing a routine message

1. Press [F1] to display the File menu.

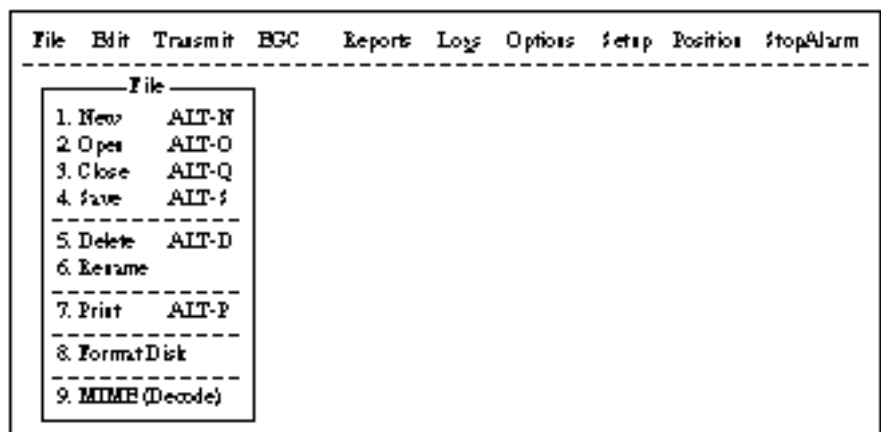

Figure 3-1 File menu

2. Press [1] to select New. The display should now look something like Figure 3-2.

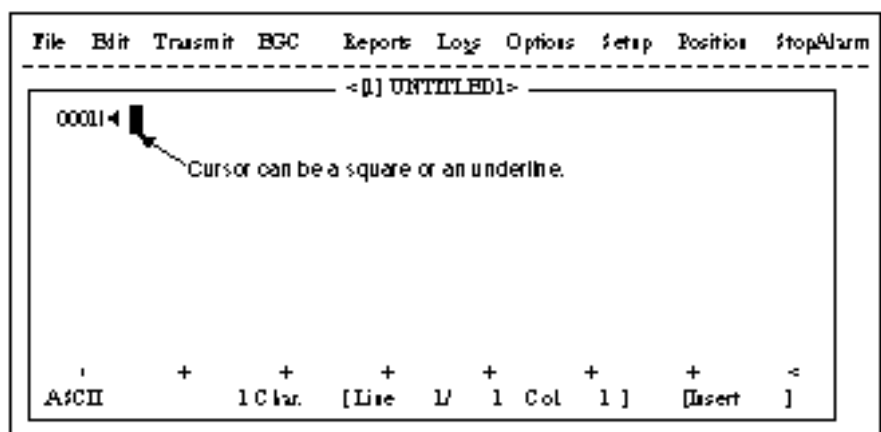

Figure 3-2 Text editor screen

**Note:** *If the text editor screen does not appear and “close” screen appears, see “Opening a file where a working area is occupied” on page 3-11.*

3. The cursor is on the first line. Type your message.

## Preparing a confidential message

If communicating with another FELCOM 12, you can prepare a confidential message by entering “S???-addressee code(-password):” in first line of message text. You can also receive confidential messages containing this header from a land subscriber or any MES which uses the FELCOM 12.

There are two types of confidential messages: message with addressee code and message with both addressee code and password.

When a FELCOM 12 receives a confidential message, the message is not displayed and printed immediately. To display or print the contents of a confidential message, the recipient executes the key sequences shown on page 4-23.

### Explanation of addressee code and password

Caller and recipient agree beforehand on both the addressee code and the password. The addressee code can be the title of the recipient; for example, CAPTAIN. The password could be the classification of the message; for example, SECRET.

#### Preparing message with addressee code

Type S, 3 question marks, hyphen, addressee code, colon followed by text of message.

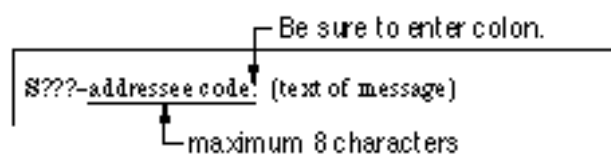

*Figure 3-3 Addressee code*

#### Preparing message with both addressee code and password

Type S, 3 question marks, hyphen, addressee code, hyphen, password, colon followed by text of message.

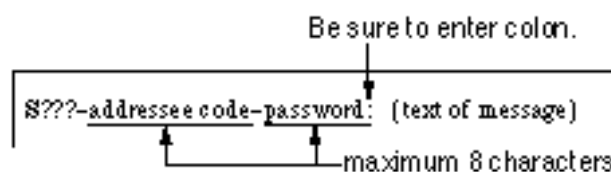

*Figure 3-4 Addressee code and password*

When the recipient receives a message with both addressee code and password, he must enter the password to view contents of the message.

## Editor menu setup

The Editor menu sets the parameters of the text editor.

1. Press [F8] to display the Setup menu.
2. Press [3] to display the Editor Setup menu.

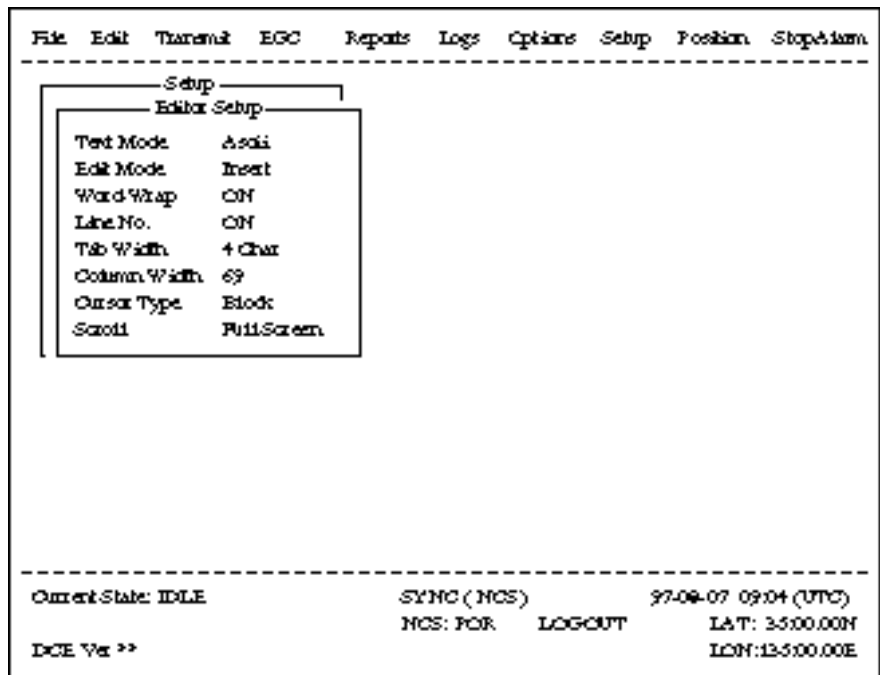

Figure 3-5 Editor setup menu

3. Figure 3-5 shows the default editor setup settings. To change settings, select item with arrow keys, press [Enter] to open selection window, and select settings with arrow keys. After selecting settings, press [Enter].

**Text Mode:** Select “Telex” or “ASCII”.

**Edit Mode:** Select “Insert” (insert character at cursor location) or “Overwrite” (write over character at cursor location).

**Word Wrap:** Turns on/off hyphenation at end of line.

**Line No.:** Turns line number display on or off.

**Tab Width:** Sets horizontal tab width; 2, 4 or 8 tabs per line.

**Column Width:** Select Telex (69 Fixed) or ASCII (40 to 80).

**Cursor Type:** Selects cursor appearance, either ■ (Block) or underline.

**Scroll:** Sets how much the screen moves up over the page (Full Screen or Half Screen) when [PgUp] or [PgDn] key is operated.

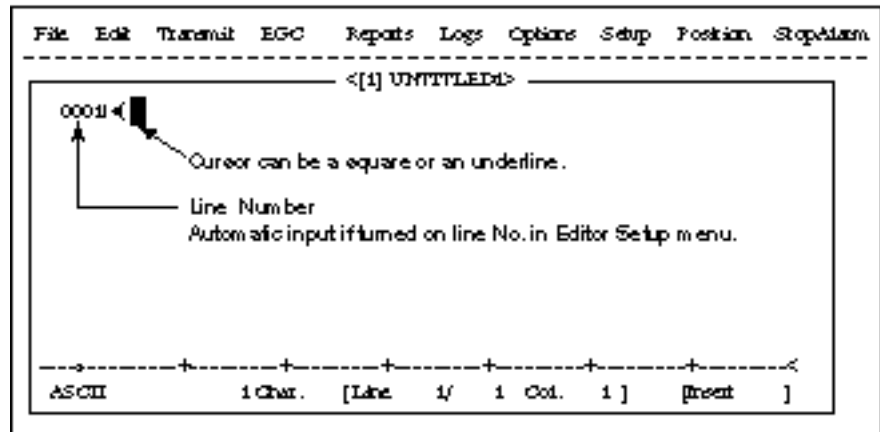

Figure 3-6 Text editor screen

### Cutting and pasting text

1. Place the cursor on the first character of the text to be cut.
2. Highlight the text to be cut by pressing [→] while pressing and holding [Shift]. You can use the right and left arrow keys to adjust the highlight. The figure below shows the appearance of highlighted text.

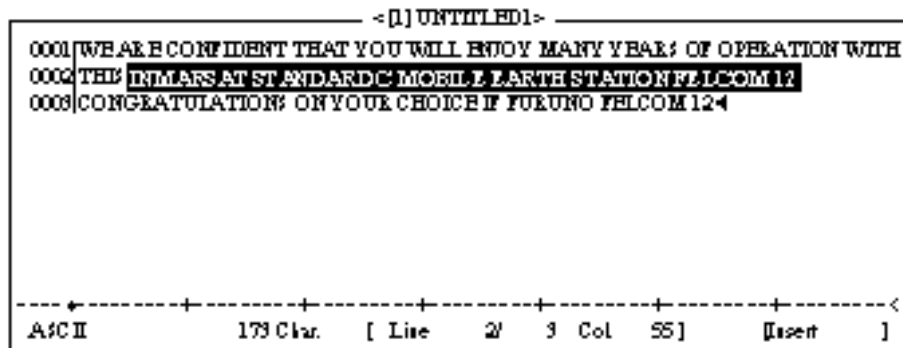

Figure 3-7 Appearance of highlighted text

3. Press [F2] to select the Edit menu.

Edit	
1. Cut	DEL
2. Copy	ALT-C
3. Paste	INS
4. Insert (With Citation)	
5. Select All	ALT-A
6. Search or Replace	
7. Goto Line	
8. Time or Pos. Ins	
9. Change Window	ALT-V

Figure 3-8 Edit menu

4. Press [1] to select Cut. The highlighted text is cut and the remaining text is reformatted. If a mistake is made, you can immediately restore the text by pressing [Insert].
5. To move text to a new location after it has been cut, place the cursor at the exact spot in the message where the cut text is to start. When the text cursor is placed correctly, press [F2] and then [3] (Paste).

## Copying and pasting text

1. Select the text you want to copy.

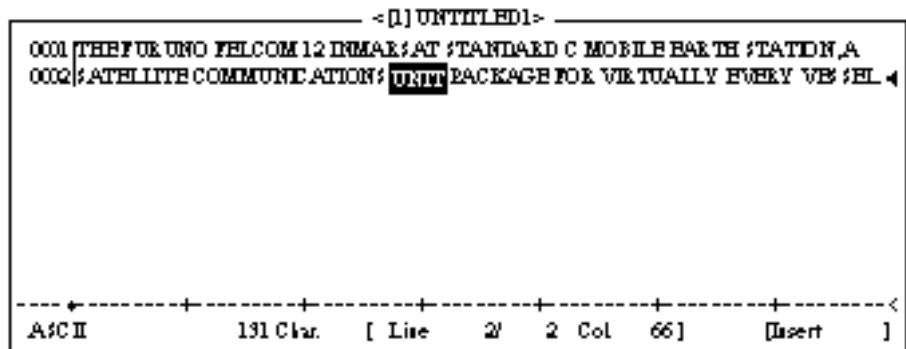

*Figure 3-9 Appearance of highlighted text*

2. Press [F2] to display the Edit menu.
3. Press [2] to select Copy. The text selected is copied to the internal clipboard.
4. Place the cursor at the exact spot on the message where the copied text is to start.

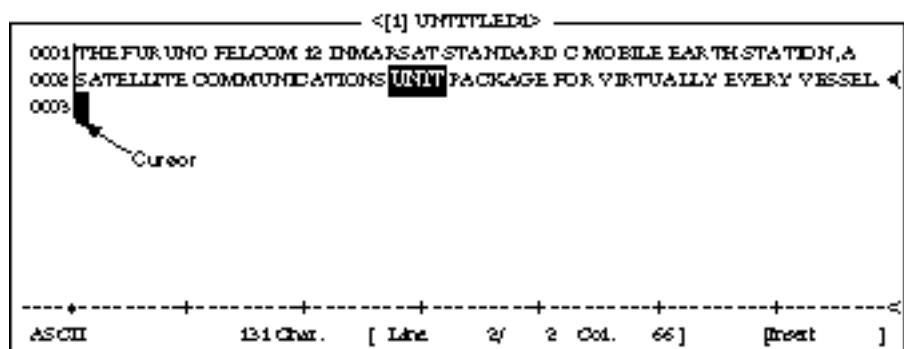

*Figure 3-10 Cursor selects location where to paste text*

5. Press [F2] followed by [3]. The text is placed at the cursor location.

```
                                -[1] UNTITLED1->
0001 THE FUTURE OF TELECOM IS IN THE AIR: AT STANDARD C MOBILE EARTH STATION, A
0002 SATELLITE COMMUNICATIONS UNIT PACKAGE FOR VIRTUALLY EVERY WEB SITE.
0003 UNIT 4
```

---

ASC II                    137 Char.    [ Line 3/ 3 Col 5]                    [Insert ]

Figure 3-11 Text pasted at cursor location

### Insert (with Citation)

When you reply to a received message, you can insert the received message. “>” is placed at the head of the received message to distinguish it from your message.

### Select All

Selects the entire current file for cut and copy.

### Search and Replace

Searches a specified word. Replaces a word with a different word or character.

### Go to line

Moves the cursor to the desired line in the current file.

1. Top of text
2. End of text
3. Go to line: Specify line number

### Time or Pos. ins

Inserts time or position in a sentence.



# Saving a Message

## Formatting a floppy disk

To save a message to a floppy disk the disk must be formatted. Formatting prepares the disk so information can be written to its surface.

1. Insert a blank floppy disk into the disk drive.
2. Press [F1].
3. Press [8].

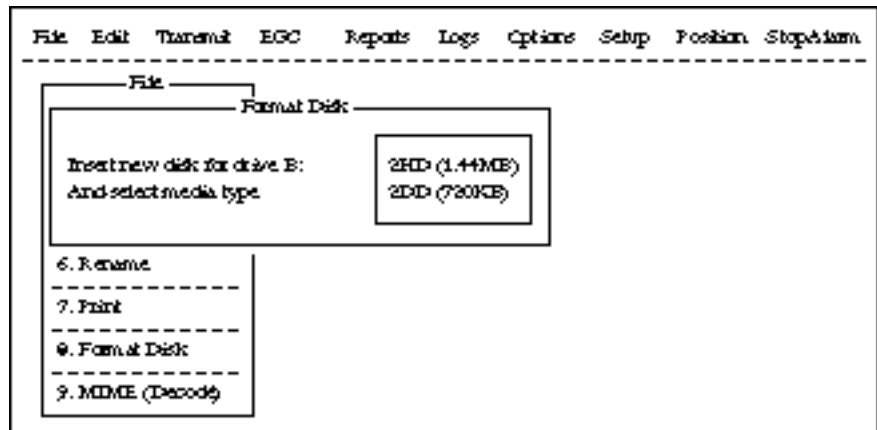

Figure 3-12 Format disk screen

4. Select media type.
5. Press [Enter].

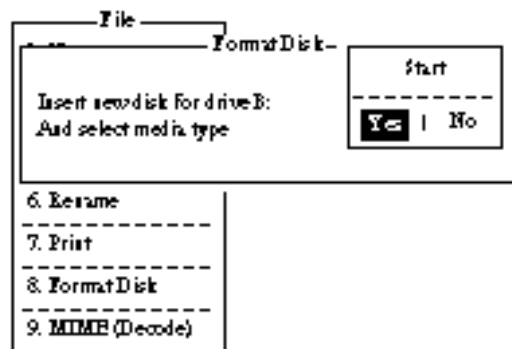

Figure 3-13 FD Format confirmation screen

6. Select “Yes” to format the disk. Press [Enter] to begin formatting.

**Note:** If there is no floppy disk in the drive, “FD not inserted in drive. Press any key to escape.” appears on the display.

7. “Now Formatting” appears on the screen during formatting.
8. When formatting is completed (about one minute), “Formatting Completed.” appears on the display. You can now return to the standby display by pressing any key.

## Saving a message

You can save a message two ways: Save it without losing your place on the screen (called “save”), or save it before clearing the screen (called “close”).

### Save message, retain place on screen

1. Press [F1] to display the File menu.
2. Press [4]. The screen should look something like Figure 3-14.

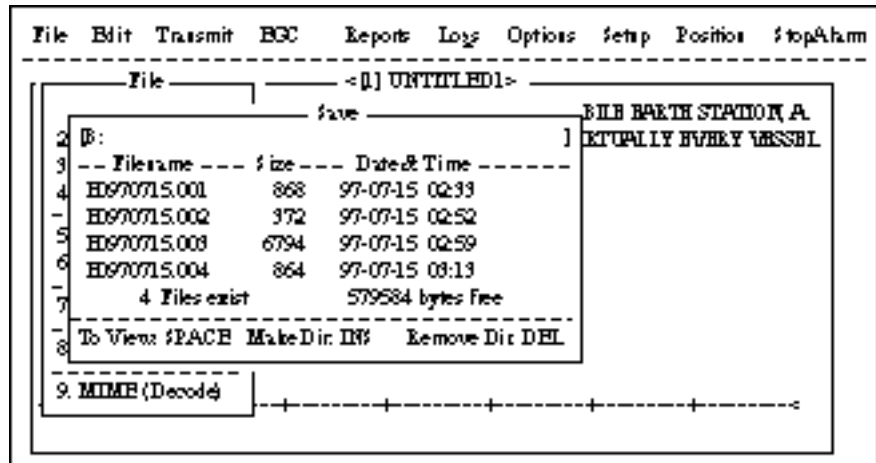

Figure 3-14 Save screen

3. Enter a file name, up to eight characters with extension name (three characters), as shown below.

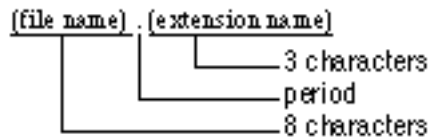
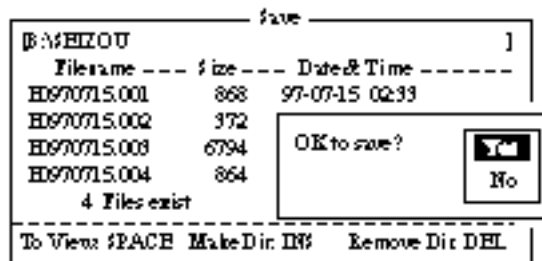

Figure 3-15 Configuration of file menu

4. Press [Enter]. “SAVING” appears on display.

## Save message, clear screen

1. Press [F1] to display the File menu.
2. Press [3]. The prompt “Save this message?” appears on the screen.

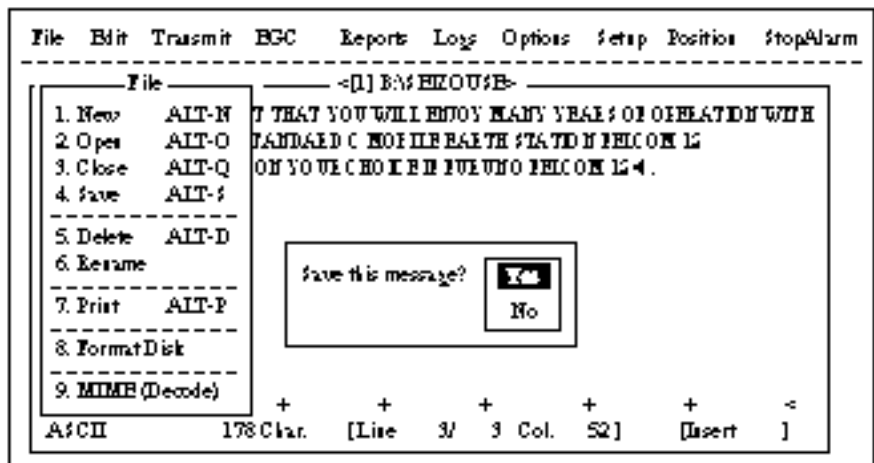

Figure 3-16 File menu, close file prompt

3. Press [Enter].

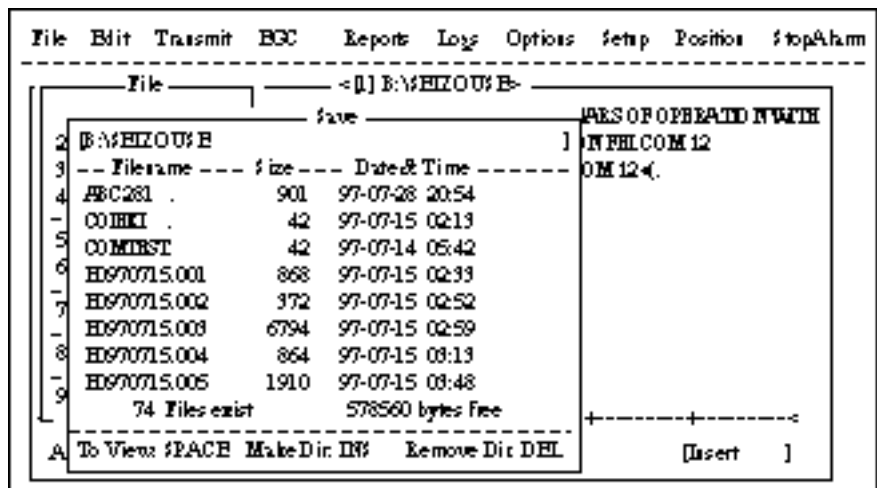

Figure 3-17 Save screen

4. Enter a file name.
5. Press [Enter].

## Opening a File

The internal memory provides two working areas where you can load one file each. Only one file can be displayed at a time, however you can easily switch between files.

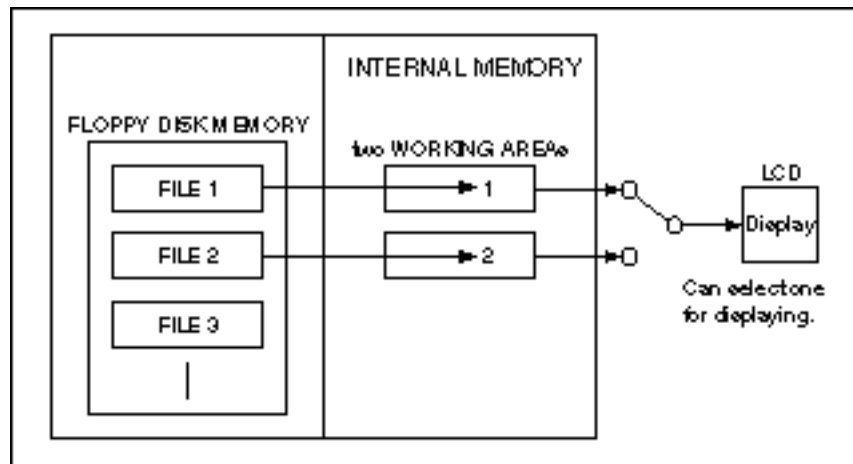

Figure 3-18 Internal memory

## Opening a file

1. Set the floppy disk containing the file you wish to open in the disk drive.
2. Press [F1] to display the File menu.
3. Press [2]. The screen shows a list of the files stored in the floppy disk.
4. Select a file.  
To view a portion of a file, press the space bar.

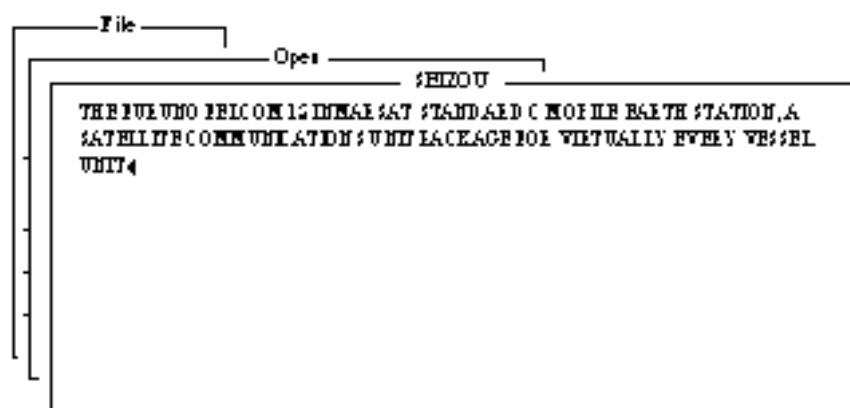

Figure 3-19 Partial view of a file

5. Press [Enter].
6. The message "Loading" appears on the screen during loading. A few moments later the contents of the file appear on the screen and the title bar shows the file name. You may repeat the above procedure to load a second file into a working area.

## Switching between files

You can switch between files by selecting Change Window in the Edit menu. Figure 3-20 illustrates how to switch between files with Change Window.

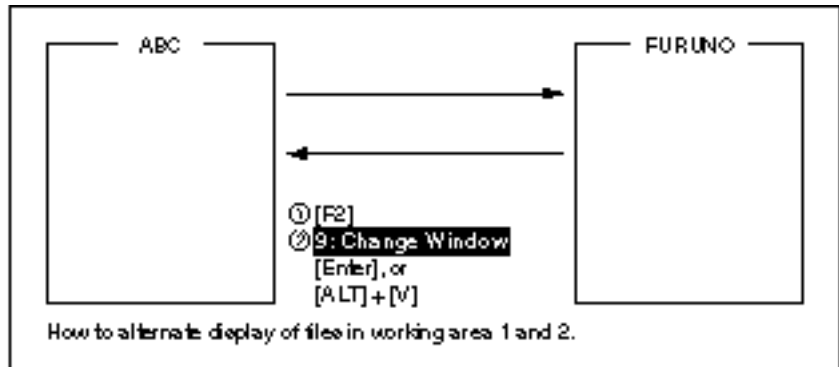

Figure 3-20 How the change window feature works

## Opening a file where a working area is occupied

When you try to load a file into an occupied working memory, the display asks you if you want to save the file in that memory before clearing the display.

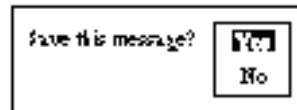

Figure 3-21 Prompt for closing a file

To save the file, press [Enter]; select “No” and press [Enter] if you do not need to save the file. The file screen is erased and then the untitled window appears.

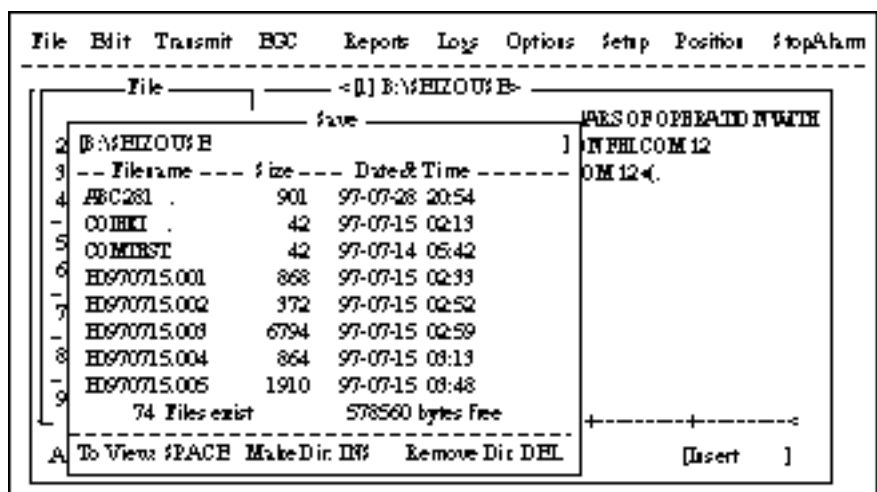

Figure 3-22 Save screen

Enter file name followed by [Enter]. The editing screen appears.

## Saving a File Under a New Name

1. Call up a file.
2. Edit the file.
3. Press [F1].
4. Press [3] (or [4]). “Save this message?” prompt appears. [3] saves file and closes screen; [4] saves file and keeps position on screen.

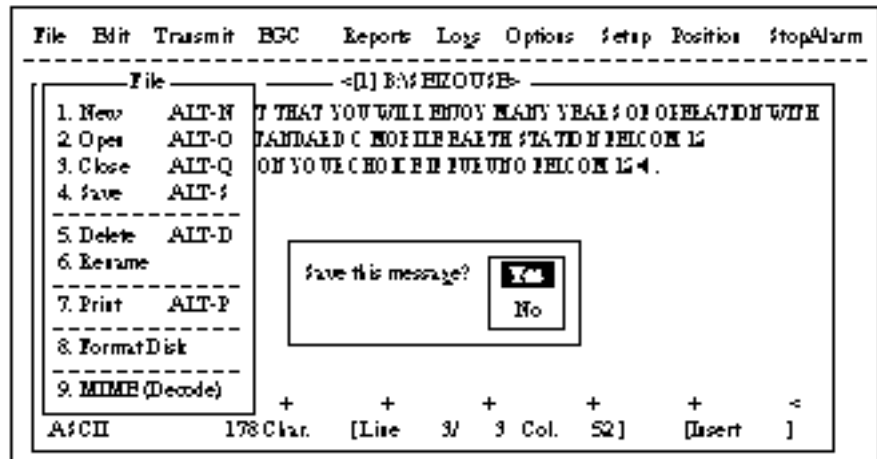

Figure 3-23 Save screen, prompt for saving a message before closing

5. Press [Enter].
6. Press [Backspace] to delete original file name. Enter file name for new file.

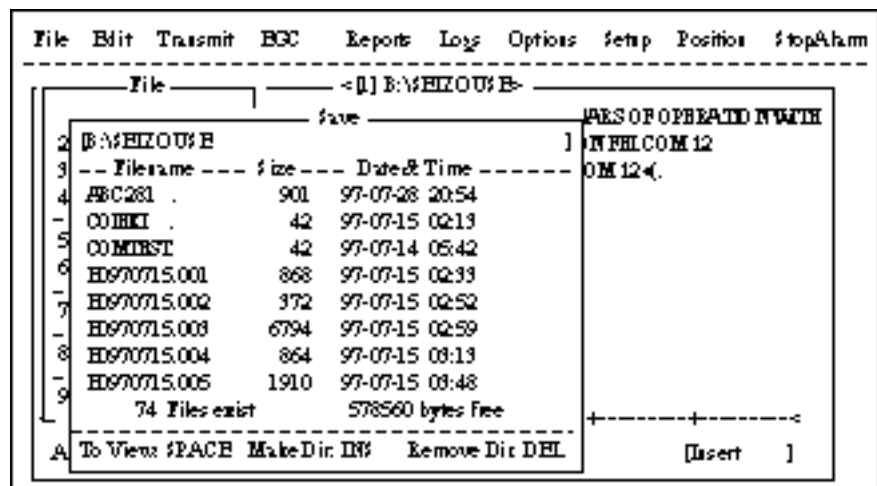

Figure 3-24 Save screen

7. Press [Enter].

**Note:** Should you decide to save the file under the original name, skip step 6. The following screen appears.

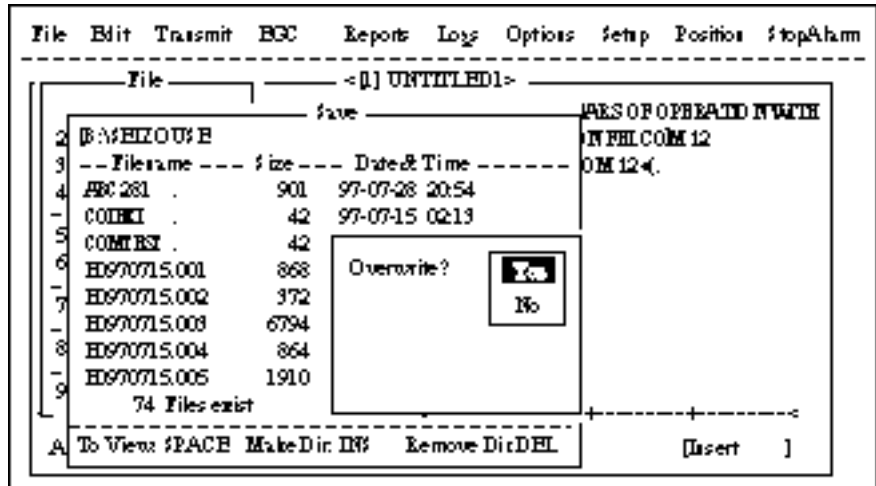

Figure 3-25 Save screen, overwrite file name

## Printing a File

You can print out a hard copy of a file stored in a floppy disk.

1. Press [F1] to display the File menu.
2. Press [7]. A list of files stored on the disk appears.

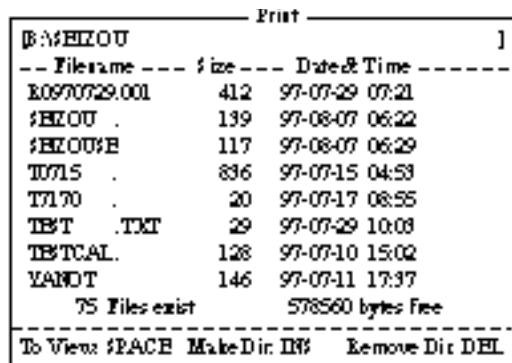

Figure 3-26 Sample print screen

3. Select a file. To get a partial display of the file, tap the space bar.
4. Press [Enter].

## Combining Files

In the procedure below we'll combine file A and B.

1. Open file A.
2. Open file B. File B appears on the display.
3. Place the cursor at the beginning of the file. While pressing and holding down [Shift] press [ ↓ ] to highlight the entire file. (You can also select a portion of the file.)
4. Press [C] while holding down [Alt]. This places file B on the clipboard.
5. Press [V] while holding down [Alt]. File B is erased and File A appears on the display.
6. Press [ ] while holding down [Fn] followed by [Enter] to place the cursor at the end of the file.
7. Press [Insert].  
The file B is inserted at the end of the file A.

## Deleting a File

1. Press [F1] to display the File menu.
2. Press [5]. A list of files stored on the disk appears.

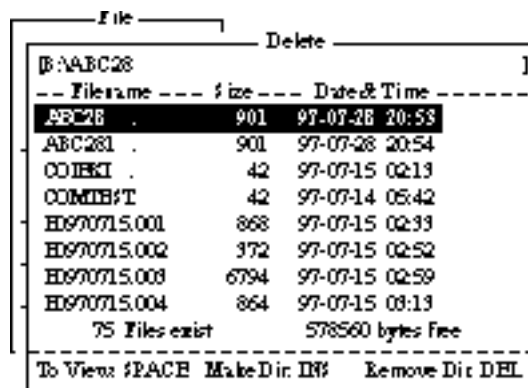

The screenshot shows a terminal window titled "File" with a "Delete" option. The main content is a list of files with columns for "Filename", "Size", and "Date & Time". The file "ABC28" is highlighted. At the bottom, it shows "75 Files exist" and "578560 bytes free".

Filename	Size	Date & Time
ABC28	901	97-07-28 20:53
ABC281	901	97-07-28 20:54
COIBKI	42	97-07-15 02:13
COMIB#T	42	97-07-14 05:42
HD970715.001	868	97-07-15 02:33
HD970715.002	372	97-07-15 02:52
HD970715.003	6794	97-07-15 02:59
HD970715.004	864	97-07-15 03:13

75 Files exist 578560 bytes free

To View: SPACE Make Dir: DN% Remove Dir: DEL

Figure 3-27 Sample delete screen

3. Select the file you want to delete. To verify the contents of that file, tap the space bar.



4. Press [Enter]. The prompt “OK to delete file?” appears.

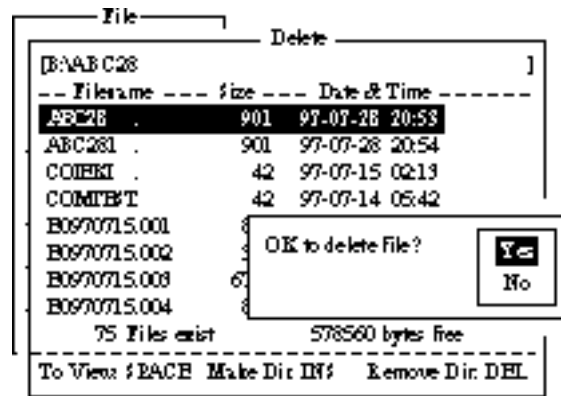

Figure 3-28 Prompt for verification of file delete

5. Press [Enter] to delete the file, or press [↓] and [Enter] to escape.

## MIME (Multipurpose Internet Mail Extensions)

When you can't read an attached file in the Log menu, you may decode it with MIME as follows:

1. Press [F1].
2. Press [9].

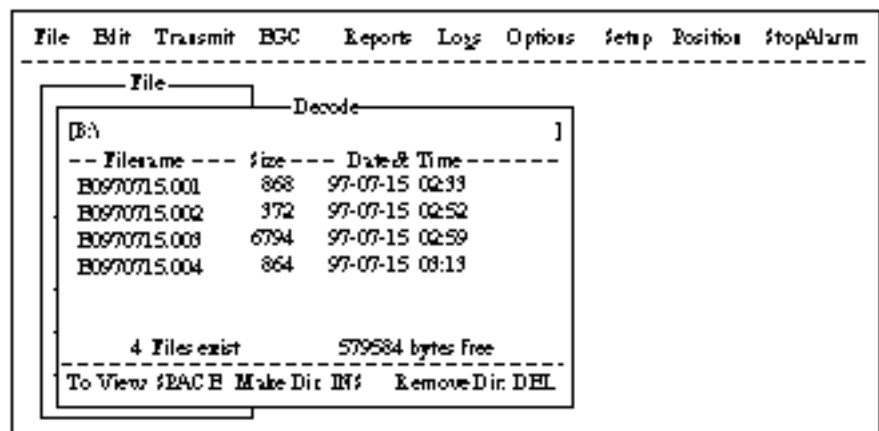

Figure 3-29 File, decode

3. Select the file you want to decode.
4. Press [Enter].

# Rename

Do the following to change file name.

1. Press [F1].
2. Press [6].

Filename	Size	Date & Time
Test.txt	901	97-07-28 20:53
ABC281 .	901	97-07-28 20:54
COMBKI .	42	97-07-15 02:13
COMBHT	42	97-07-14 05:42
B0970715.001	868	97-07-15 02:33
B0970715.002	372	97-07-15 02:52
B0970715.003	6794	97-07-15 02:59
B0970715.004	864	97-07-15 03:13

75 Files exist 578560 bytes free

To View: F PAGE Make Dir: DIR Remove Dir: DEL

Figure 3-30 File, rename

3. Select a file you want to rename.
4. Press [Enter].

Rename

Enter new filename

Test.txt █

Figure 3-31 Rename window

5. Delete old file name and then type new file name.
6. Press [Enter].

# INMARSAT-C COMMUNICATIONS

---

This chapter explains how to transmit and receive in the Inmarsat-C system.

Before conducting any communications, be sure to login with the NCS in your area.

To transmit E-mail, register with the LES provider. E-mail charges are calculated separately.

## Transmitting

To transmit a message, you first create the message, attach the address of the recipient and send it to the LES. The address of the recipient in the Inmarsat-C system is his telex number for land-line or MES Inmarsat Mobile Number (IMN) for ship.

The message can be one you've just prepared or one stored on a floppy disk. (Messages cannot be transmitted by means of direct keyboard input.)

### Code description

Code can be specified at the IB-581 or PC.

IA5: International alphabet No. 5, ASCII code (7 bit).  
Specify this code to transmit English containing lower case alphabet.

ITA2: No. 2 international communications alphabet (5 bit).  
Specify this code for message which contains only No. 2 international communications alphabet (see A-11). ITA2 code is transmitted faster than IA5 code.  
Land-based telex equipment uses ITA2. The LES converts all codes into ITA2. Code which cannot be converted is shown with a question mark (?).

DATA: Data (8 bit). Use this code to transmit data.

*Table 4-1 Message, subscriber destination and code*

Message	Subscriber	Destination Type	Code	Remarks
English	Inmarsat C Sta.	TELEX	IA5	
	Telex	TELEX	ITA2	
	Fax	PSTN	IA5	Modem type is T30 FAX.
	E-mail	E-Mail	IA5	
Russian	Inmarsat C Sta.	PSDN	DATA	
	Telex	TELEX	ITA2	THERMOPYLAE (305) and PEATH (222)
	Fax	Not available		
	E-mail	E-Mail	DATA	
Japanese	Inmarsat C Sta.	PSDN	DATA	
	Telex	Not available		
	Fax	Not available		
	E-mail	E-Mail	DATA	
Data	Inmarsat C Sta.	PSDN	DATA	
	Land Network	PSDN	DATA	

## Transmitting prepared message

This section explains routine telex transmission. For distress communication, see page 6-1.

For 2-digit code services and PSTN (FAX) communication, see page 4-17, respectively.

### common procedure for transmitting a message

1. Prepare message on the screen.
2. Press [F3] to display the Transmit menu.

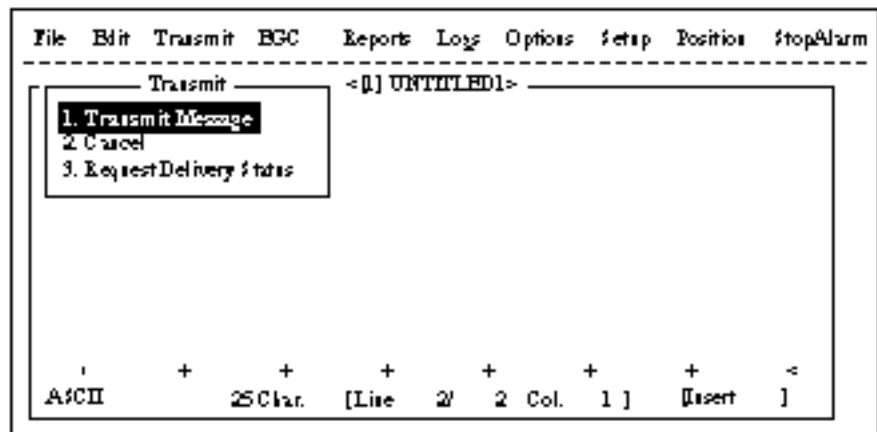

*Figure 4-1 Transmit menu*

- Press [Enter] or [1] to display the Transmit Message menu. The cursor is on the Priority line and “Normal” is selected.

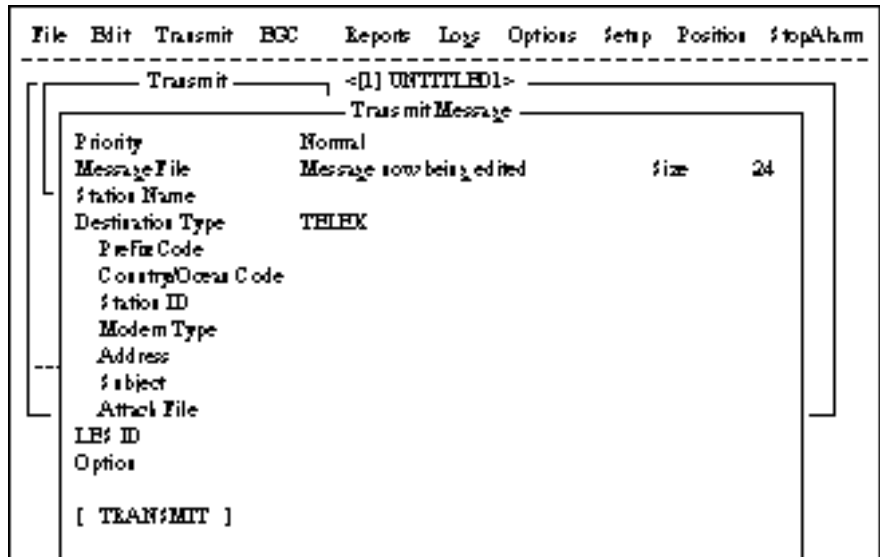

Figure 4-2 Transmit message menu

**Note:** An error message may appear under the conditions below:

*Unit is not logged-in. -Error message: Cannot start to send. (not logged-in)*

*Unit operates as an EGC-only receiver-Error Message: Cannot start to send. (EGC receiver)*

The message file line displays “Message now being edited” when a file is currently displayed.

- Press [ ↓ ] three times to place the cursor on the Destination Type line.
- Press [Enter] to open the selection window.
- Select Destination Type among “TELEX”, “FAX” or “SPEC (Prefixed)”.

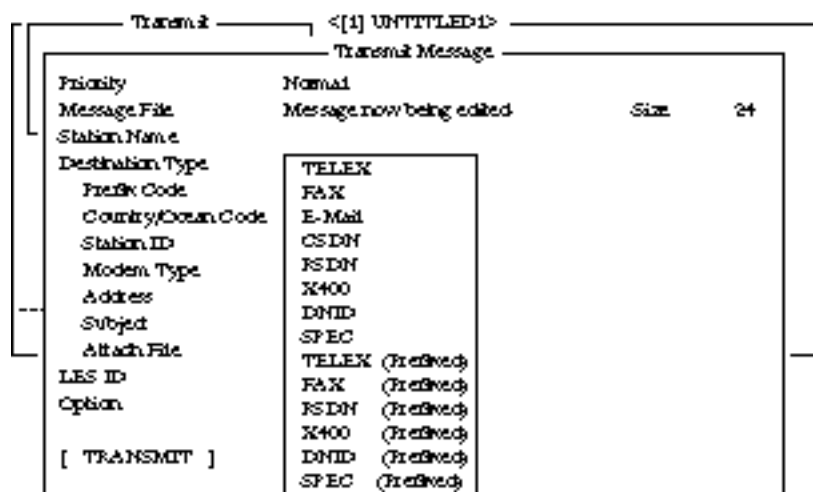

Figure 4-3 Transmit message menu, destination type window

- Press [Enter] to close selection window.

8. Follow instructions below for TELEX (Prefixed), or go to page 4-5 for FAX or E-Mail.

Destination type: TELEX (Prefixed)

- (1) Press [ ↓ ] to place the cursor on the Prefix Code line.
- (2) Press [Enter] to open the window for prefix code entry.
- (3) Key in prefix code in the digits.  
Note that some services may not be available depending on LES.

Prefix Code	Function
11	Operator's Assistance
12	Dial Guide
33	Technical Assistance
91	Automatic Telex Test
⋮	⋮

- (4) Press [Enter] to close the window.
- (5) Press [ ↓ ] to place the cursor on the Country/Ocean Code line.
- (6) Press [Enter] to open the window for country/ocean code entry.
- (7) Type either international telex country code of recipient (ship-to-shore) or ocean region (ship-to-ship). A list of international telex country codes begins on page A-1 in the Appendix.

Ocean Region

AOR-East: 581  
 POR: 582  
 IOR: 583  
 AOR-West: 584

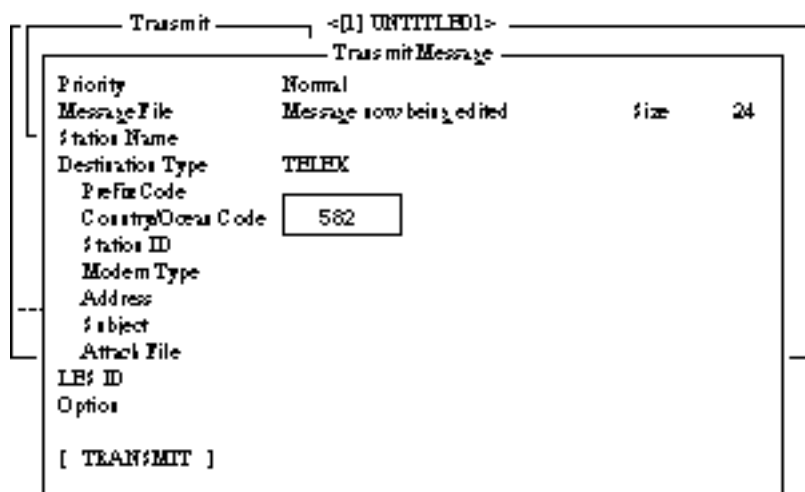

Figure 4-4 Transmit message menu, country/ocean code window

- (8) Press [Enter] to close the window.

- (9) Press [ ↓ ] to send the cursor to the Station ID line.
- (10) Press [Enter] to open the window for station ID entry.

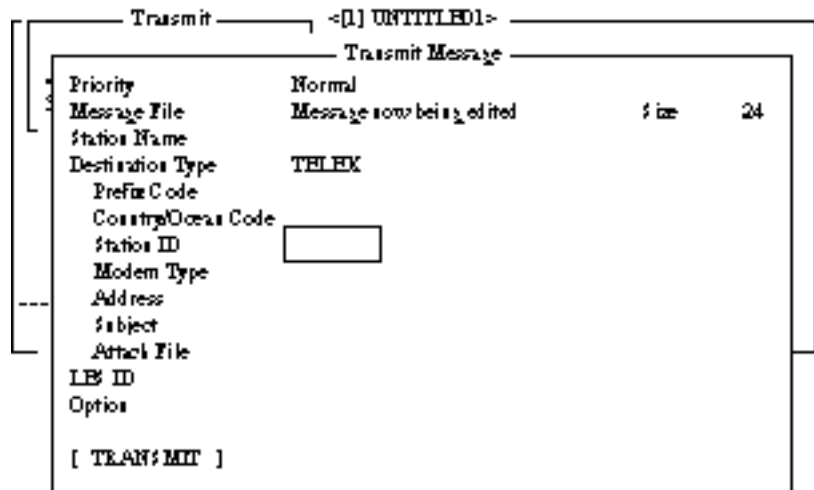

Figure 4-5 Transmit message menu, station ID window opened

- (11) Type either recipient's telex subscriber number (ship-to-shore) or receiving MES INM (ship-to-ship).
- (12) Press [Enter] to close the window.
- (13) Go to step 9 at the top of page 4-7.

Destination type: FAX

- (1) Press [ ↓ ] to advance the cursor to the Modem Type line.
- (2) Press [Enter] to open the selection window.

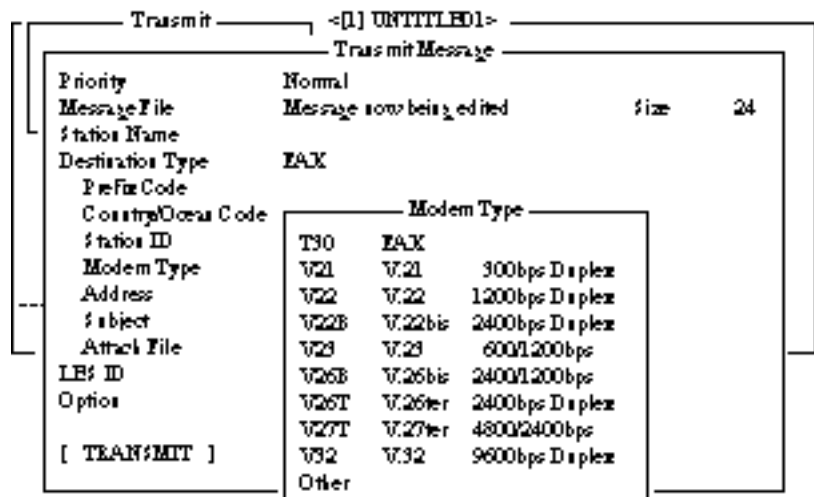

Figure 4-6 Transmit message menu, modem type window opened

- (3) Select "T30".
- (4) Press [Enter] to close the selection window.
- (5) Go to step 9 at the top of page 4-7.

Destination type: E-mail

- (1) Press [ ↓ ] to advance the cursor to the Address line.

(2) Press [Enter] to open the window for address entry.

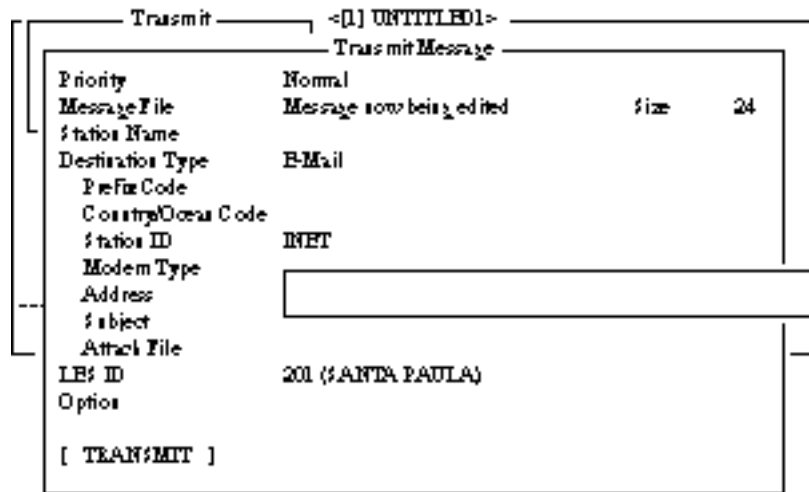

Figure 4-7 Transmit message menu, address window

(3) Type recipient's E-mail address.

(4) Press [Enter] to close the window.

(5) Press [↓] to advance the cursor to the Subject line.

(6) Press [Enter] to open the window for subject entry.

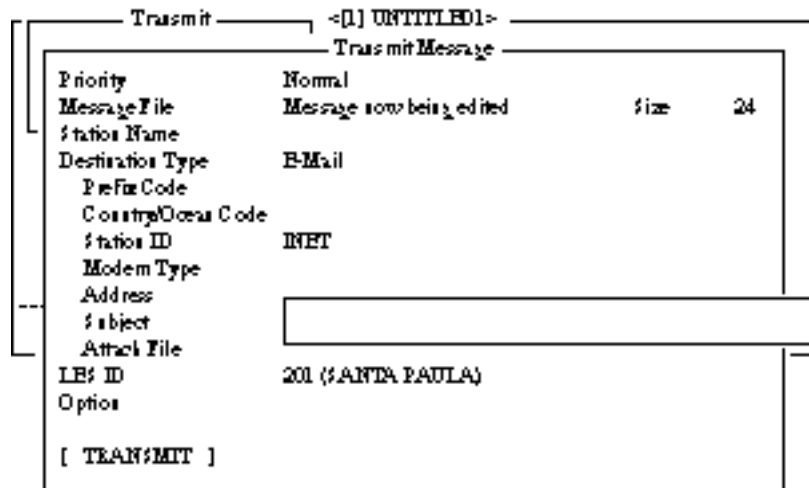

Figure 4-8 Transmit message menu, subject window opened

(7) Type subject.

(8) Press [Enter] to close the window.

(9) Press [↓] to advance the cursor to the Attach File line.

(10) Press [Enter] to open the select File window.



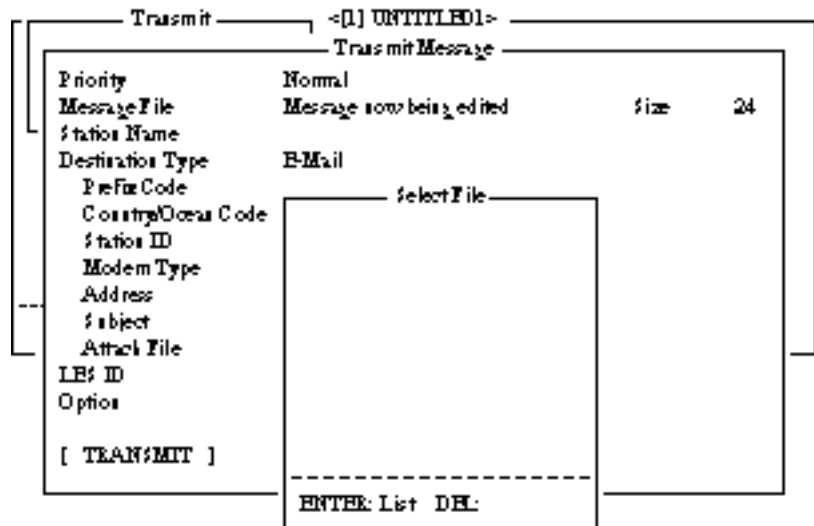

Figure 4-9 Transmit message menu, select file window opened

- (11) Press [Enter] to open the file list window.  
To change drive on a PC, move the cursor to the command line, type drive name (for example, "A"), and move the cursor to anywhere in the File Name column.
- (12) Press [Enter] to select file and close the file list window.
- (13) Press [Esc] to close the select file.  
Go to step 9 at the top of the next page.

**procedure for transmitting a message (con't from page 4-5 )**

- 9. Press [ ↓ ] to advance the cursor to the LES ID line.
- 10. Press [Enter] to open the selection window.

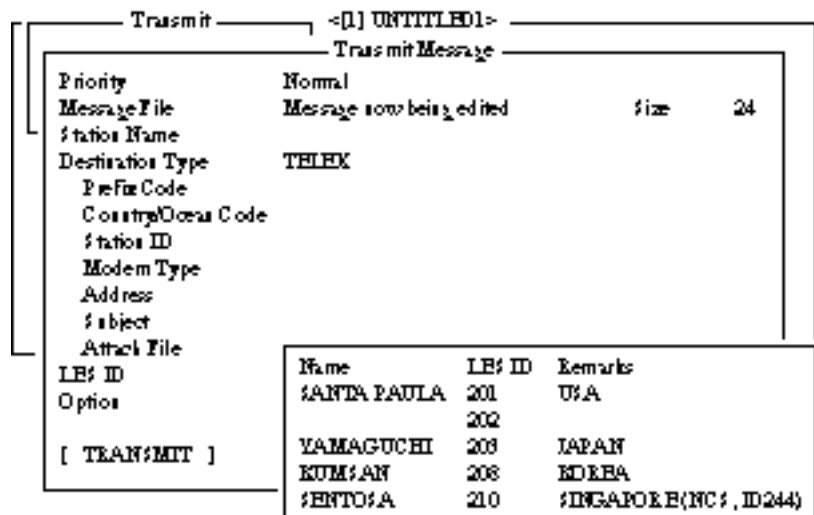

Figure 4-10 Transmit message menu, LES ID window opened

**Note:** If the LES ID entered is invalid, "Cannot use this LES. Please check network configuration." appears.

- 11. Select LES ID.
- 12. Press [Enter] to close the selection window.

13. Press [ ↓ ] to send the cursor to the Option line.

14. Press [Enter] to open the option window.

Transmit Message	
Priority	Normal
Message File	Message now being edited
Station Name	
Destination Type	TELEX
Prefix Code	
Country/Ocean Code	
Station ID	
Modem Type	
Address	
Subject	
Attach File	
LES ID	
Option	Confirmation ON
	Send Delay 00:00
	Delivery Delay Immediate
	Code IA5

[ TRANSMIT ]

*Figure 4-11 Transmit message menu, option window opened*

15. Press [Enter] to open the selection window.

16. To receive confirmation from the LES when message has been delivered to recipient, select ON. If not required, select OFF.

17. Press [Enter] to close the selection window.

18. Press [ ↓ ] to send the cursor to the Send Delay line.

19. Press [Enter] to open the window for send delay entry.

20. To send a message after a certain delay enter a time up to 99 hours 59 minutes.

(The Send Delay is used to time message arrival to suit recipient's office hours.)

21. Press [Enter] to close the window.

22. Press [ ↓ ] to go to the Delivery Delay line.

23. Press [Enter] to open the selection window.

24. The Delivery Delay line requests the LES for "Immediate" or "Deferred" transmission to the recipient designated. Select either immediate or deferred. For information on this service, consult with LES to which message is to be sent.

25. Press [Enter] to close the selection window.

26. Press [ ↓ ] to send the cursor to the Code line.

27. Select "IA5", "ITA2" or "DATA".

Normally, IA5.

28. Press [Enter] to close the selection window.

29. Press [Esc] to close the option window.

30. Press [ ↓ ] to place the cursor on TRANSMIT.

31. Press [Enter] to open the start window.
32. Press [Enter] to transmit the message to the message buffer. (To escape, select No and press [Enter].) The message “Message is entered in sending Buffer.” appears and the message prepared is printed.

**Note:** *The message buffer can only hold one message. However a second message may be sent to the buffer by assigning a Send Delay to it.*

*When the message buffer is full, “Cannot enter this message to sending Buffer.” appears to alert you.*

33. Press any key to return to the standby display.

The message(s) will be transmitted according to Send Delay setting. “Current State: SENDING” appears at the bottom of the screen during transmission.

If the message was transmitted successfully “Successful Sending message” appears and its particulars are sent to the Display Log.

### TRANSMIT MESSAGE STATUS

*The terminal unit displays transmit message status as follows:*

*“Message Send failed.” This appears if the message could not be transmitted because of technical reasons such as satellite malfunction, signal degradation, or no reply from LES. Try to transmit the message again.*

*“Message Send rejected.” This appears when the LES rejects the message because of non-technical reasons such as unpaid subscriber’s fee.*

*“Message Send pending.” This appears when the circuits at the LES are busy. Your message will be transmitted when a circuit becomes clear.*

### Transmitting message stored on floppy disk (multiple address)

1. Close any open files.
2. Insert floppy disk containing file to be sent. (Be sure to insert the floppy disk completely in the drive. Otherwise, “FD not inserted in drive.” appears.)
3. Press [F3] to display the Transmit menu.

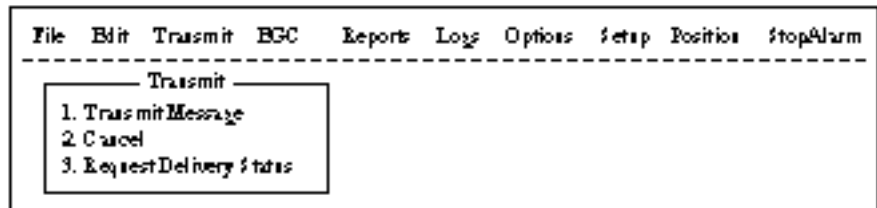

Figure 4-12 Transmit menu

4. Press [1] to select Transmit Message.

The cursor is on the Priority line and “Normal” is selected.

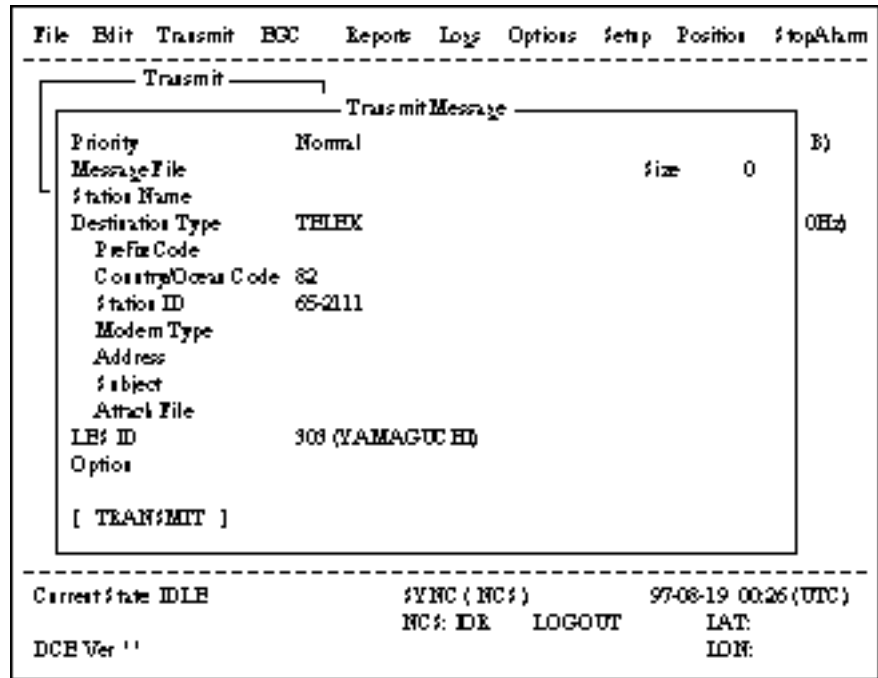

Figure 4-13 Transmit message menu

5. Press [↓] to advance the cursor to the Message File line.

6. Enter the file name manually, or select it from the message file list of the floppy disk as follows.

a) Press [Enter] to display Message File list.

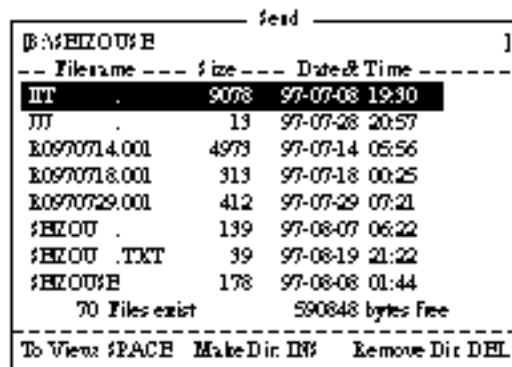

Figure 4-14 File list

- b) Select a file.
  - c) Tap the space bar to display a portion of the file in the view window.
  - d) Press [Enter]. The Message File screen appears with the file selected.
7. Press [ ↓ ] to advance the cursor to the Station Name line.
  8. Press [Enter] to open the Station List.

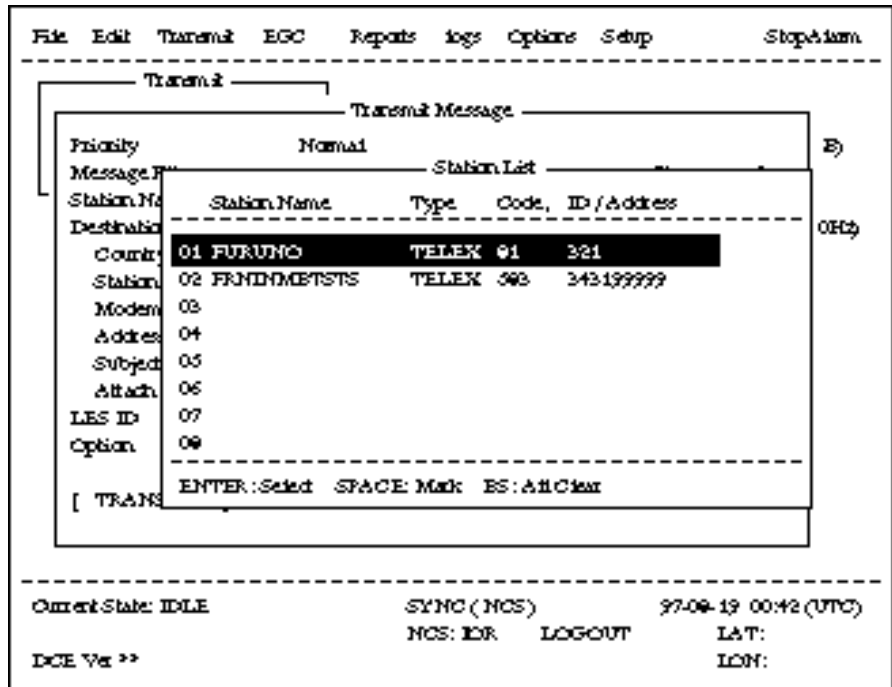

Figure 4-15 Select station screen

9. Select station and press [Enter].  
To select more than one station, press [Space] bar after selecting station. An asterisk appears next to station(s) selected.

**Note :** Different types or prefix code of messages cannot be transmitted simultaneously.

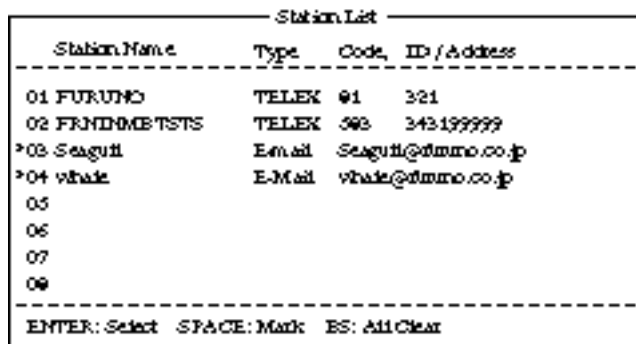

Figure 4-16 With asterisk mark

10. Press [ ↓ ] key to advance the cursor to the LES ID line.
11. Press [Enter] to open the LES Table.

Name	LES ID	Remarks
YAMAGUCHI	303	JAPAN
HIK	304	NORWAY
THERMOPYLAH	305	GREECE (NC#, ID344)
ARVI	306	INDIA
KUMSAN	308	KOREA

Figure 4-17 LES list

```

File Edit Transmit BGC Reports Log Options Setup Position StopAlarm
-----
Transmit
-----
Transmit Message
-----
Priority Normal
Message File size 0
Station Name
Destination Type TELEX
Prefix Code
Country/Ocean Code 82
Station ID 65-2111
Modem Type
Address
Subject
Attach File
LES ID
Option
[ TRANSMIT ]
-----
Current State IDLE SYNC ( NC# ) 97-08-19 00:26 (UTC)
NC# ID LOGOUT LAT:
DCB Ver ' ' ION:

```

Name	LES ID	Remark
Perth	302	IOR
Perth	202	FOR
Singapore	210	FOR
	203	
	201	

Figure 4-18 Sample LES table

- a) Select LES.
  - b) Press [Enter].
  - c) The Transmit Message screen appears with selected LES displayed on the LES ID line.
12. Follow steps 13 thru 28 in the previous section.
  13. Press [↓] to place the cursor on TRANSMIT.
  14. Press [Enter] twice to transmit the message.

```

----- Transmit Message -----
Priority Normal
Message File $HIS/STU.TXT size 46
Station Name FURUND
Destination Type TELEX
Prefix Code
Country/Ocean Code 81
Station ID 321
Modem Type
Address
Subject
Attach File
LES ID 303 (YAMAGUCHI)
Option
[ TRANSMIT ]
-----
Start
-----
Yes | No

```

Figure 4-19 Transmit message menu

**Note:** If a file name which was entered manually does not exist when you attempt to transmit the file at step 13. "Input Error: Message File" appears. Press any key to erase the error message then enter correct name.

## Canceling transmission

As noted earlier a transmit message is held in the buffer, usually until it is transmitted satisfactorily. To cancel transmission on a message held in the buffer, do the following:

1. Press [F3] to display the Transmit menu.
2. Press [2] to display the Cancel screen.

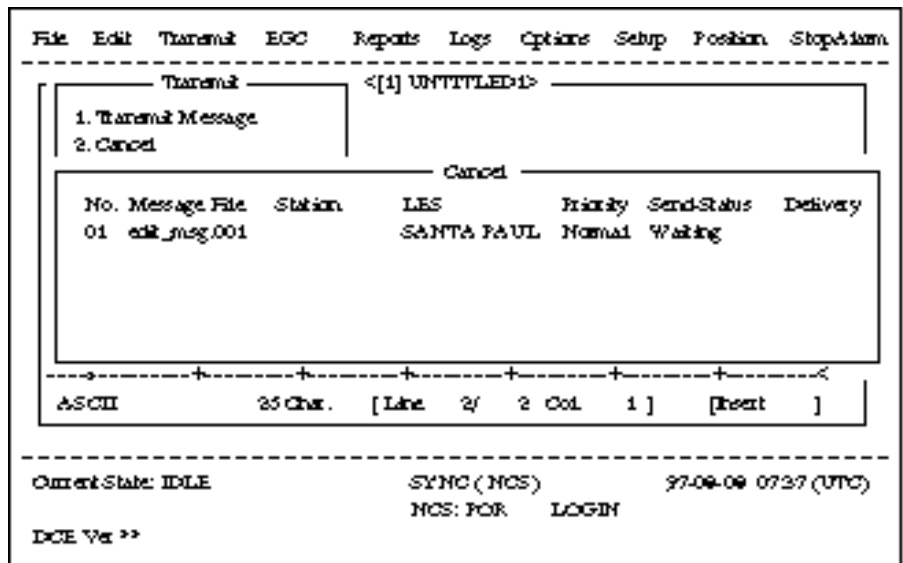

Figure 4-20 Sample cancel screen

### Send status

- Waiting:** Waiting to transmit message.
- Sending:** Now sending message.
- Fail:** Failed transmission
- Rejected:** Message rejected by LES.
- Pending:** LES circuits occupied.

3. Select message you want to cancel.

4. Press [Enter] to open the Cancel window.

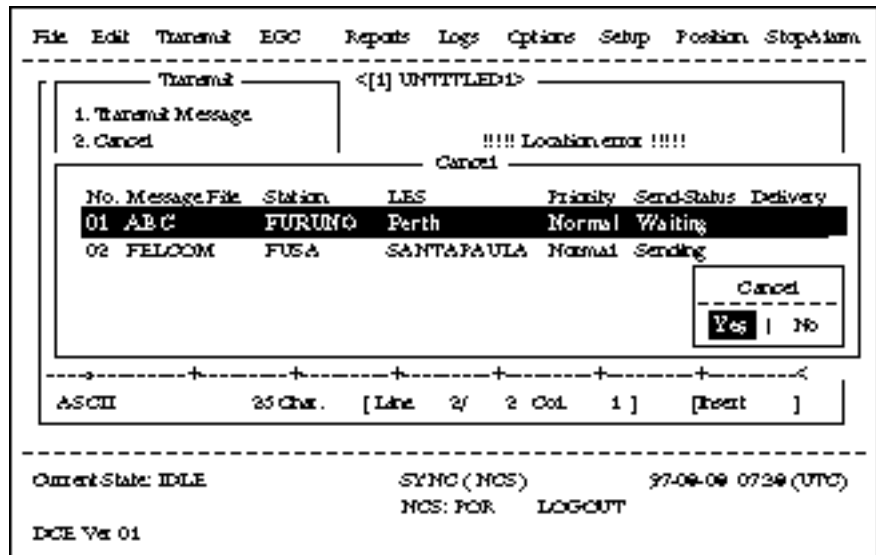

Figure 4-21 Cancel window

5. Press [Enter] to cancel a message from transmission, or select “No” and press [Enter] to escape from the Cancel menu.
6. Press [Esc] to return to the default display.

### Confirming delivery status (message status list)

You can automatically receive delivery status of messages you send to a LES, by selecting “Confirming ON” in the Send Message menu. (Delivery Status can also be confirmed manually. See page 4-16.) Messages transmitted which request delivery status appears in the Message Status List.

The Message Status List holds delivery status information for 30 messages. When the list is full, the oldest entry is deleted to make room for the latest.

1. Press [F3].

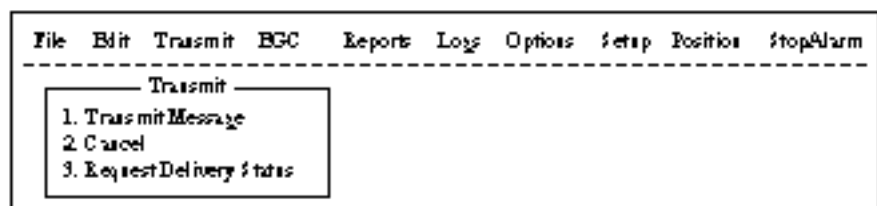

Figure 4-22 Transmit menu



2. Press [3] to display the Request Delivery Status menu.

Request Delivery Status						
No.	Message File	Station	LES	Priority	Send Status	Delivery
01	ABC	FUKURO	Yamaguchi	Normal	Waiting	
02	DEF	FUKURO	Yamaguchi	Normal	Sending	
03	GHI	A:DEA:DF	202	Normal	97-09-20 9:40	OCC(002)
04	JKL		308	Normal	97-09-18 20:16	
05	MNO	ABCDEFGHIU	123	Normal	97-09-18 16:09	Complete
06	editmsg_002		202	Normal	97-09-18 9:48	HEB(001)
07	editmsg_001		Yamaguchi	Normal	97-09-16 12:34	????

Figure 4-23 Sample request delivery states

### Message status list description

- No.:** Message number
- Message File:** File name. For no file name, “edit msg. 00X” appears (X = number from 001-999).
- Station:** Name of remote party (recipient)
- LES:** The LES which received the message.
- Priority:** Normal or distress
- Send Status:** The transmission status from the MES (own ship) to the LES; waiting or sending, and data and time of transmission for messages transmitted.
- Delivery:** The delivery status from the LES to the recipient.  
 Complete: Message transmitted successfully  
 White space: Delivery status not yet received  
 Reason for no delivery:

- OCC(002): Delivery tried (twice), but recipient busy.
- ABS: Absent subscriber
- BK: Message aborted
- BMC: No end of message or end of transmission received
- DER: Out of Order
- DTE: Remote DTE clearing
- EOS: Element of Service not subscribed (E-mail)
- FMT: Format error
- IAB: Invalid answerback
- INC: Inconsistent Request (E-mail)
- INF: Call the Network Information service
- INV: Invalid Call
- ITD: Awaiting delivery
- LDE: Maximum message length exceeded
- LPE: Local Procedure Error
- NA: Access Barred
- NC: Network Congestion
- NCH: Subscriber's number has been changed
- NP: Not Obtainable
- NRC: Reverse charging acceptance not subscribed
- RIS: Recipient Improperly Specified (E-mail)
- RDI: Redirected call
- RPE: Remote Procedure Error

- RSB: Retransmission still being attempted
- TMD: Maximum number of addresses exceeded
- UNK: Unknown status (for example when the Logical channel number is zero)

**Note:** Some LES do not use certain codes.

## Manually requesting delivery status

You can request a LES for delivery status of a message you have transmitted there within the past 24 hours.

1. Press [F3].
2. Press [3] to display the Request Delivery Status display.

Request Delivery Status						
No.	Message File	Station	LES	Priority	Send Status	Delivery
01	ABC	FURUKO	Perth	Normal	97-11-06 16:10	
02	editmsg_002	FURUKO	Perth	Normal		

Figure 4-24 Request delivery status display

3. Select a file.
4. Press [Enter]. A prompt asks you if you want to request delivery status on that message.

Request Delivery Status						
No.	Message File	Station	LES	Priority	Send Status	Delivery
01	ABC	FURUKO	Perth	Normal	97-11-06 16:10	
02	editmsg_002	FURUKO	Perth	Normal		

Start
-----
Yes   No

Figure 4-25 Sample message file list

5. Press [Enter] to request status. "Request started" appears on the display. (To cancel request, select "No" and press [Enter].)
6. "Press any key." appears on the display; press any key to return to the standby display.

Several minutes later the reply from the LES appears in the Delivery column of the Request Delivery Status screen.

## The 2-digit code services

A range of special safety and general maritime services, known as the 2-digit code services, may be received. The list on the next page shows the 2-digit code services available.

To access a 2-digit code service;

1. Using the text editor, prepare message requesting a 2-digit code service. (Refer to next page.)
2. Press [F3] to display the Transmit menu.
3. Press [Enter] to display the Transmit Message.

The screenshot shows a terminal window with a menu titled "Transmit Message". The menu items are:

- Priority: Normal
- Message File: Message now being edited
- Station Name
- Destination Type: TELEK
- Prefix Code
- Country/Ocean Code
- Station ID
- Modem Type
- Address
- Subject
- Attach File
- LE# ID
- Option

At the bottom of the menu, there is a prompt: [ TRANSMIT ]

Figure 4-26 Transmit message menu

4. Press [ ↓ ] three times to place the cursor on the Destination Type line.
5. Press [Enter] to open the selection window.
6. Select "SPEC" (Special).
7. Press [Enter] to close the selection window.
8. Press [ ↓ ] to place the cursor on the Station ID line.
9. Press [Enter] to open the window for station ID entry.
10. Key in 2-digit code referring to the tables on the next page.
11. Press [Enter] to close the window.

**For maritime safety service;**

32	Medical advice	Used for requesting medical advice.
38	Medical assistance	Used for requesting medical assistance.
39	Maritime assistance	Used for requesting maritime search and rescue assistance.
41	Meteorological reports	Necessary for ease of addressing weather reports from ships to meteorological centers.
42	Navigational Hazards and warnings	Used for making urgent navigational meteorological danger reports.
43	Ship position reports	Used for routing of messages to ship safety reporting systems.

**For general utility;**

31	Maritime enquiries	Desirable for requesting information including service offerings.
33	Technical assistance	Desirable for addressing technical enquiries to appropriate personnel.
37	Time and charges requested at end of call	Desirable for mobile operator when sending traffic for a third party.

12.Press [ ↓ ] to advance the cursor to the LES ID line.

13.Press [Enter] to open the LES table.

14.Press [Enter] to select LES ID.

15.Press [ ↓ ] to place the cursor on TRANSMIT.

16.Press [Enter]. A prompt asks if it is alright to start transmission. (The Confirmation, Send Delay and Delivery Delay remain “ON”, “00:00” and “Immediate”, respectively. If necessary, change these settings before pressing [Enter].)

17.Press [Enter] to transmit the message prepared.

18.Press any key to return to the standby display.

The message will be transmitted according to Send Delay setting. “Current State: SENDING” appears at the bottom of the screen during transmission.

If the message was transmitted successfully “Successful Sending message” appears and its particulars are sent to the Display Log.

**Note 1:** *At present, not all LESs are offering the 2-digit code services. To find out which LESs are offering the services, contact the LES Operations Coordinator directly.*

**Note 2:** *Some 2-digit code services may be provided free of charge by LESs, while other services are chargeable, in some cases at reduced rates. For information, contact the LES directly.*

## Inserting the destinations of a fax terminal

You can send a text message to a Group 3 type fax terminal which is connected to the international PSTN (telephone) land line, provided the LES selected supports fax delivery.

1. Prepare message. (To send stored file, close any open files.)
2. Press [F3] to display the Transmit menu.
3. Press [1] to select Transmit Message.  
The cursor is on the Priority line and “Normal” is selected.
4. Press [ ↓ ] to advance the cursor to the Message file line.
5. The message file line displays “Message now begin edited.” when a file is the currently displayed. To send a file stored on a floppy disk, select the file from the file list.
6. Press [ ↓ ] to advance the cursor to the Destination Type line.
7. Press [Enter] to open the selection window.
8. Select “FAX”.
9. Press [Enter] to close the selection window.

```

                                Transmit Message
-----
Priority           Normal
Message File      Message now being edited      Size   77
Station Name
Destination Type  FAX
  Prefix Code
  Country/Ocean Code
  Station ID
  Modem Type
  Address
  Subject
  Attach File
LE# ID
Option
[ TRANSMIT ]
```

Figure 4-27 Transmit message menu, FAX selected

10. Press [ ↓ ] to advance the cursor. The cursor is now on the Country/Ocean Code line.
11. Press [Enter] to open the window for country/ocean code entry.
12. Key in international telephone code of recipient. A list of international telex/telephone country codes begins on page A-1 in the Appendix.
13. Press [Enter] to close the window.
14. Press [ ↓ ] to send the cursor to the Station ID line.
15. Press [Enter] to open the window for station ID entry.
16. Enter facsimile number.

17. Press [Enter] to close the window.
18. Press [ ↓ ] to send the cursor to the Modem Type line.
19. Press [Enter] to display the list of modem types.
20. Press [Enter] to select “T30”. (Other modem types are not supported.)
21. Press [ ↓ ] to advance the cursor to the LES ID line.
22. Press [Enter] to open the LES Table.
23. Select LES ID.

**Note:** *If the LES ID entered is invalid, “Cannot use this LES. Please check network configuration.” appears.*

24. Press [Enter] to close the LES Table.
25. Press [ ↓ ] twice to place the cursor on TRANSMIT.
26. Press [Enter] twice to send the message to the message buffer. (To escape, select No and press [Enter].) The message “Message is entered in sending Buffer.” appears. At the same time, the message prepared is printed.
27. Press any key to return to the standby display.

The message(s) will be transmitted according to the Send Delay setting. “Current State: SENDING” appears at the bottom of the screen during transmission.

When the message is transmitted successfully “Successful Sending message” appears and its particulars are sent to the Display Log.

## Receiving

### When a message is received

Each time the FELCOM 12 receives a message it automatically registers, saves, prints (except messages with passwords) and files it.

#### 1) registration

Each message received is assigned a receive message number. This number is also used when the file is saved to a floppy disk.

<u>R</u>	<u>0</u>	<u>9 7</u>	<u>0 1</u>	<u>1 5</u>	<u>0 0 1</u>
Receive	0: main DTE 1: 2nd DTE	year	month	day	receive message no.

## 2) display log

The Display Log shows message number, priority, date and time of transmission, LES ID and file size (in bytes) of the latest 50 received and transmitted messages.

## 3) printing

Printing of a message begins (except messages with passwords) as soon as it is received.

## 4) saving and filing

The DTE saves and files a receive message to the Display Message List. (For installations with both a main and a 2nd DTE, you may select where to store receive messages, on the system setup menu.) The Display Message List shows the following:

Receive message no.  
LES ID  
Priority  
File size (in bytes)  
Message classification  
Password for confidential messages  
Date and time of transmission  
Status

## Setting the receive alarm

An audible alarm may be set to ring when a routine message is received. The factory setting is OFF.

1. Press [F8] to display the Setup menu.
2. Press [6] to display the Auto Mode Setup.



Figure 4-28 Auto mode setup menu

3. Press [↓] to send the cursor to the Receive Alarm line.
4. Press [Enter] to open the selection window.
5. To enable the alarm, select ON. The alarm will be released for one second when a message is received.

6. Press [Enter] to close the selection window.
7. Press [Esc] twice.

## Displaying receive messages

When you can't read an attached file in Log menu refer to page 3-15.

1. Press [F6].
2. Press [2] to display list of receive messages.

Message No.	LES	Priority	Size	Addressee	Rec date & Time	Status
R0971106.001	Perth	Normal	32767		97-11-06 16:10	Saved
R0971105.002	ABCDEF/TEAM	Normal	200	CAPTAIN	97-11-05 17:30	
R0971105.001	Perth	Distress	1234		97-11-05 14:15	Printed
R0971024.001	Perth	Normal	8251		97-10-24 13:20	Saved

Space display part view

Memory Available: 12345 Bytes

Part View Window

Figure 4-29 Sample display message screen

### Display message list description

<b>Message No.:</b>	Receive message no.
<b>LES:</b>	LES name
<b>Priority:</b>	Normal or distress
<b>Size:</b>	Size of file in bytes
<b>Addressee:</b>	Addressee code appears for confidential messages. Nothing appears for routine messages.
<b>Rec date &amp; time:</b>	Date and time message was received.
<b>Status:</b>	Printed: message printed Saved: message saved to floppy disk No display: not yet printed confidential message, or printer malfunction
<b>Memory available:</b>	Memory available in DTE

3. Select a file. To get a partial display of a file selected, tap the space bar. A part of the file appears in the View Window.



- Press [Enter] for routine messages and messages with addressee code (no password).  
Your selection appears on the display.

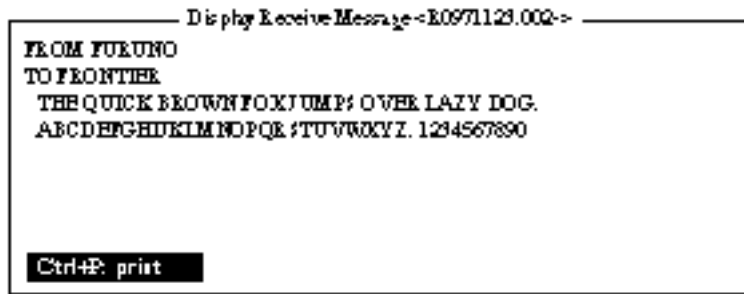

Figure 4-30 Sample receive message

- For messages with both addressee code and password, a Password window appears. Enter the password corresponding to the addressee code and then press [Enter]. If the password is entered incorrectly an alarm sounds. Reenter the password.

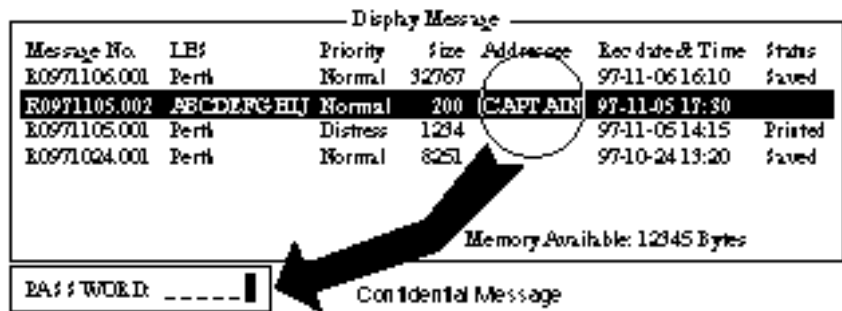

Figure 4-31 Location of password

The screen can be scrolled with the up and down arrow keys.

## Printing receive messages

- Follow steps 1 thru 6 in “Displaying receive messages”.
- While pressing and holding down [Ctrl], press [P]. The printer starts printing the message on the screen.

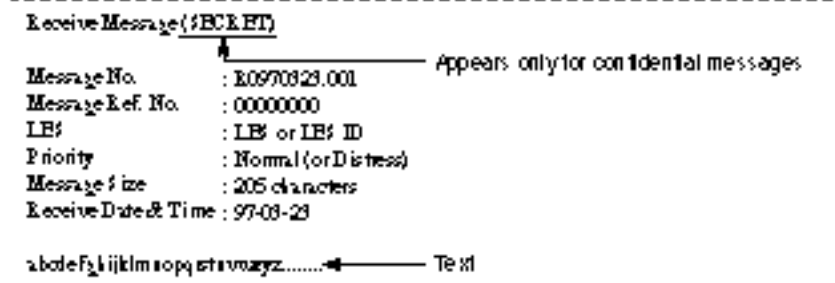

Figure 4-32 Sample receive message printout

## Saving receive messages to a floppy disk

1. Press [F6].
2. Press [2] to display the Receive Message Log.

Receive Message Log						
Message No.	LE#	Priority	Size	Addressee	Rec date& Time	Status
R0971106.001	Pertk	Normal	32767		97-11-06 16:10	Saved
R0971108.002	ABCDEF/TEAM	Normal	200	CAPTAIN	97-11-05 17:30	Printed
R0971105.001	Pertk	Distress	1234		97-11-05 14:15	Printed
R0971101.001	Pertk	Normal	3256	OFFICER	97-11-01 3:45	Printed
R0971024.001	Pertk	Normal	8251		97-10-24 13:20	Saved

Memory Available: 3317 Bytes

---

Enter: Display S: Save D: Delete

Figure 4-33 Sample delete message screen

3. Select a file. To display a portion of the file selected, tap the space bar.
4. For confidential messages enter password. This password will also be saved to the floppy disk.
5. Press [Enter] to copy the file to the floppy disk. "Saving to FD" appears during saving.

**Note:** If a file by that name already exists on the floppy disk, "A file by that name already exists on FD." appears.

## Automatically saving receive messages

1. Press [F8].
2. Press [6] to display Auto Mode Setup menu.

Setup	
Auto Mode Setup	
Auto Log Print	OFF
Receive Alarm	ON
Auto Telex Msg Save	ON
Auto BGC Msg Save	OFF
7. E-Mail Setup	
8. Directories	
9. Configuration	

Figure 4-34 Auto mode setup menu

3. Press [↓] to select "Auto Telex MSG Save".
4. Press [Enter] to open the selection window.
5. Select "ON".
6. Press [Enter] to close the selection window.
7. Press [Esc] twice.

The drive and directory where to save receive messages and created files can be specified with “MSG Directory”. The default setting is as follows;

For IB-581 B:\  
 For PC “MAIL” directory in directory which stores program files

**Note:** For IB-581 do not specify the ROM disk (drive A) as the “MSG directory.” The ROM disk can only be written to 1000 times.

Receive messages are automatically assigned a file name as described on page 4-20.

EGC messages can also be automatically saved. EGC messages are automatically assigned a file name and they begin with E.

### Deleting receive messages

1. Press [F6].
2. Press [2] to display list of receive messages.

Delete Message						
Message No.	LE#	Priority	Size	Addressee	Rec date & Time	Status
E0971106.001	Perth	Normal	32767		97-11-06 16:10	S ved
E0971105.002	ASCDEN/TEAM	Normal	200	CAPTAIN	97-11-05 17:50	Printed
E0971105.001	Perth	Distress	1284		97-11-05 14:15	Printed
E0971101.001	Perth	Normal	3256	OFFICER	97-11-01 3:45	Printed
E0971024.001	Perth	Normal	8251		97-10-24 13:20	S ved

Memory Available: 3317 Bytes

Part View Window

Figure 4-35 Sample delete message screen

3. Select the message you want to delete. To display a part of a message (except confidential messages), tap the space bar.
4. To view a portion of a confidential file, enter the password and then tap the space bar.
5. Press [D]. You are asked to confirm.
6. Press [Enter] to delete the message, or select No and press [Enter] to escape.
7. To return to the standby display, press [Esc] three times.

## Distress/Urgent Receiving Call Unit IC-303

The IC-303 releases an audible alarm when a normal priority message and distress or urgency of navtex is received. You can silence the normal priority alarm by pressing the ALARM RESET button.

For distress or urgency of navtex, you can silence the audible alarm by pressing the [F10] key on the key board of terminal unit.

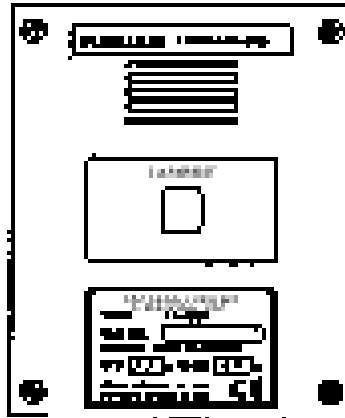

Figure 4-36 Distress/Urgent Receiving Call Unit IC-303

## Display Log

The Display Log stores the particulars of the latest 50 received and transmitted messages. When the log is full, the oldest message is deleted.

### Displaying and printing the display log

1. Press [F6].
2. Press [4] to display the Display Log.

Message No.	Type	Pri	Date	Time	LE#	Station	Size	Cond	
01 ;	T0971110.001	TELEX	Nrm	97-11-10	19:10	302	FURUKUNO	12345	Success
02 R	R0971110.001	TELEX	Dis	97-11-10	19:25	302	- - - - -	365	- Fail

P:TN  
 P:DN  
 E-mail  
 (etc)

Ctrl+E: print

Figure 4-37 Sample display log

3. To scroll the Display Log screen, press the down key several times.

4. To print the log, press and hold down [Ctrl] and press [P].  
“Now printing” appears on the screen.

To stop printing, press [Esc].

### display log description

<b>S/R:</b>	Send or Receive message
<b>Message No.:</b>	Message no. or file name
<b>Type:</b>	Currently, TELEX, PSTN, PSDN or SPEC (2-digit code service).
<b>Pri:</b>	Normal or distress
<b>Date:</b>	Date message was received (or transmitted).
<b>Time:</b>	Time message was received (or transmitted).
<b>LES:</b>	ID of LES which handled the message
<b>Station:</b>	Transmitting station name. Blank for unregistered station or receive message.
<b>Size:</b>	Size of message in bytes
<b>Cond:</b>	Transmission results. Blank if receive message.
	Success: Successful transmission
	Fail: Failed transmission
	Rejected: Message rejected by LES

### Automatic printing of display log

The Display Log can be automatically printed every 24 hours.

1. Press [F8] to display the Setup menu.
2. Press [6] to display the Auto Mode Setup menu.



Figure 4-38 Auto mode setup menu

3. Press [Enter] to open the selection window of Auto Log Print.
4. Set Auto Log Print to ON.
5. Press [Enter] to close the selection window.
6. Press [Esc] twice.

## Display send message log or receive message log

You can display send message log or receive message log as follow.

1. Press [F6].
2. Press [1] (Send message log) or [2] (Receive message log).
3. Press [Esc] to escape.

## EGC Messages

EGC messages are automatically received, printed and saved to the DTE. The memory capacity for EGC message is 32k bytes. When the memory is full, the oldest information is deleted.

### Displaying and reprinting EGC messages

1. Press [F6].
2. Press [3]. The Display EGC Message screen appears.

```
File Edit Transmit EGC Reports logs Options Setup StopAlarm
-----
Display EGC Message
EGC Message -- MET Navarea Warning or MET Forecast --
Message Sequence No. : 00472
LES : YAMAGUCHI
Priority : Urgent
Size : 285 characters
Receive Date & Time : 97-09-19 06:09 (UTC)

ZCZC
NAVAREA XI WARNING
NAVAREA XI 0490.
NORTH PACIFIC, WESTERN PART.
DISTRESS SIGNALS ON 243MHZ AND
121.5 MHZ RECEIVED IN
29-40.4N 174-15.0E.
Ctrl+F: Print P: Previous N: Next
-----
Current State: IDLE SYNC (NCS) 97-09-19 07:15 (UTC)
NCS: IDR LOGIN LAT: 3500.00N
DCE Ver ** ION: 13500.00E
```

Figure 4-39 Sample Display EGC Message screen

3. To scroll the message, use the up and down arrow keys.
4. To view next and previous messages, use the [N] and [P] keys.
5. To print the message appearing on the display, press and hold down [Ctrl] and press [P]. To stop printing, press [Esc].

EGC messages can be automatically saved on a floppy disk. See page 4-24 for details.

## Displaying EGC closed network ID (ENID)

To join a FleetNET™ service, an MES must be registered with an information provider. The information provider adds the MES to the group which is to receive the service by downloading a Group Call ID, via a LES which supports FleetNET™ broadcasts, uniquely addressed to the MES. The MES stores the ID and can accept broadcasts from the information provider. The MES operator can not change this stored EGC closed network IDs (ENIDs). Up to 64 ENIDs are stored on a non-volatile memory.

The ENID stored can be accessed for downloading and deleting via the satellite path. It is possible for an MES operator to inhibit (or activate as required), via the DTE, selected ENIDs previously downloaded.

Along with the ENID, the name of the information provider is stored. In the event that a download command is received and the ENID storage area is full, then an ENID which has been inhibited (de-activated) by the MES operator will be written over. If none has been inhibited, then the new download is not accepted.

Follow the procedure below to inhibit (or activate) an ENID.

1. Press [F4] to display EGC menu.
2. Press [2] to display the EGC Network ID List.

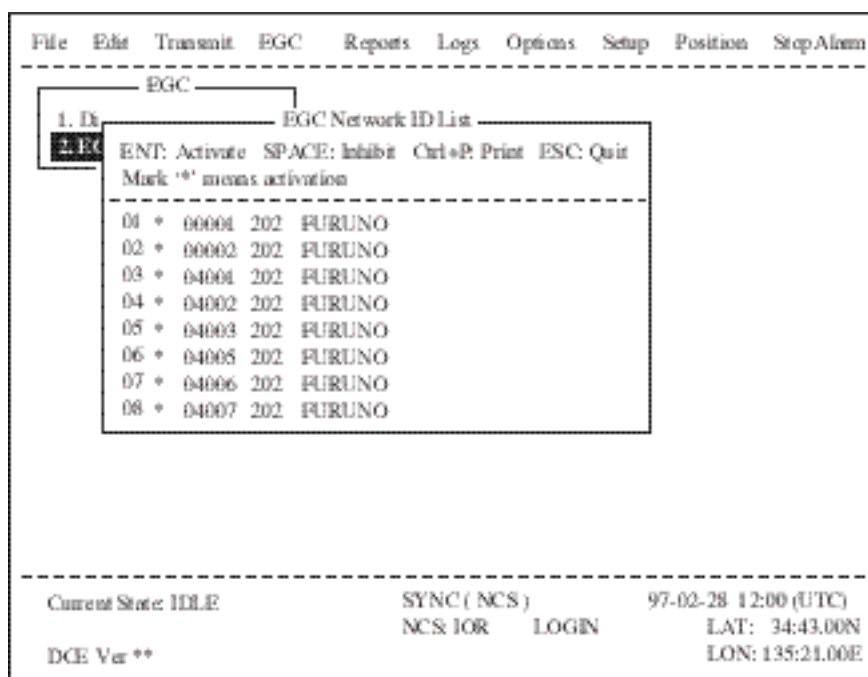

Figure 4-40 EGC network ID list

3. Select an ENID you want inhibit (or activate).
4. Press the Space bar to inhibit (or [Enter] key to reactivate).
5. Press [Esc] to return to the standby display.

### **Receiving EGC distress or urgent message**

When the FELCOM 12 receives a EGC distress or an urgent message, an alarm buzzer sounds on the terminal unit and the Distress/Urgent Receiving Unit IC-303 or the Distress Message Controller DMC-5 when connected.

To silence the alarm buzzer, press [F10] on the terminal unit.

**Note:** *To silence the alarm from the IC-302, also press . DO NOT press the DISTRESS button on the IC-302 to silence the alarm; you will transmit own ship's distress alert.*



# DATA REPORTING AND POLLING

---

This chapter explains data reporting settings and polling reception.

## Data Reporting

Data reporting provides automatic data transmission at regular (pre-set) intervals from your ship to your home office. The data are position, speed, bearing and other data sent from a navigational equipment or an interface unit.

The data transmitted from the FELCOM 12 is temporarily stored in a data reporting file at the LES. When an operator at your home office accesses the LES, the LES delivers the data to your home office. Some LESs may deliver it without being accessed.

Data reporting can be initiated by setting a data report on the FELCOM 12 or receiving a polling command from your home office.

FELCOM 12 offers two types of data reporting as follows:

- Data report -----on MES signalling channel  
Refer to “Setting a data report” below.
- Message report --- on MES message channel  
Refer to “Setting a message report” on page 5-4.

### Setting a data report

1. Press [F5] to display the Position Reports menu.



*Figure 5-1 Position reports menu*

2. Press [Enter] or [1] to display Data Report setting screen.  
The cursor is on the Status line and “OFF” is selected.

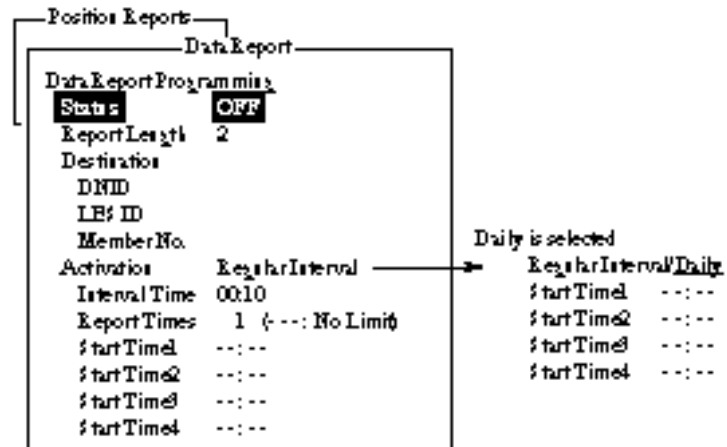

Figure 5-2 Data report menu

3. Press [Enter] to open the selection window.
4. Select “ON” or “OFF”.
  - ON: Data report on
  - OFF: Data report off
5. Press [Enter] to close the selection window.
6. Press [ ↓ ] to advance the cursor to the Report Length line.
7. Press [Enter] to open the selection window.
8. Select “1” or “2”.
  - 1: Position
  - 2: Position, speed, bearing, depth
  - 3: Spare (not used)
9. Press [Enter] to close the selection window.
10. Press [ ↓ ] to advance the cursor to the Destination line.
11. Press [Enter] to display the DNID list.
12. Select DNID.  
(LES ID and Member ID are automatically selected with DNID.)
13. Press [Enter] to close the DNID list.
14. Press [ ↓ ] to advance the cursor to the Activation line.
15. Press [Enter] to open the selection window.
16. Select “Regular Interval” or “Daily”.
17. Press [Enter] to close the selection window.

18. Press [ ↓ ].

- When “Regular Interval” is selected on step 16,
  - (1) Press [Enter] to open the window for interval time entry.
  - (2) Key in the interval time at Interval Time.
  - (3) Press [Enter] to close the window.
  - (4) Press [ ↓ ].
  - (5) Press [Enter] to open the window for report times entry.
  - (6) Key in the Report times or select “No limit”.
  - (7) Press [Enter] to close the window.
- When “Daily” is selected on step 16,
  - (1) Press [Enter] to open the window for start time entry.
  - (2) Key in the start time at Start Time 1.
  - (3) Press [Enter] to close the window.
  - (4) Press [ ↓ ].
  - (5) If necessary, key in the start time of Start Times 2-4.

19. Press [Esc] to register the above settings.

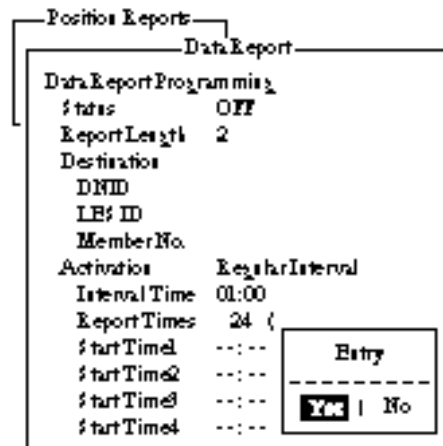

Figure 5-3 Data report menu

20. Select “Yes”.

21. Press [Enter] to close the Data Report window.

## Setting a message report

1. Press [F5] to display the Position Reports menu.



Figure 5-4 Position reports menu

2. Press [2] to display the Message Report.

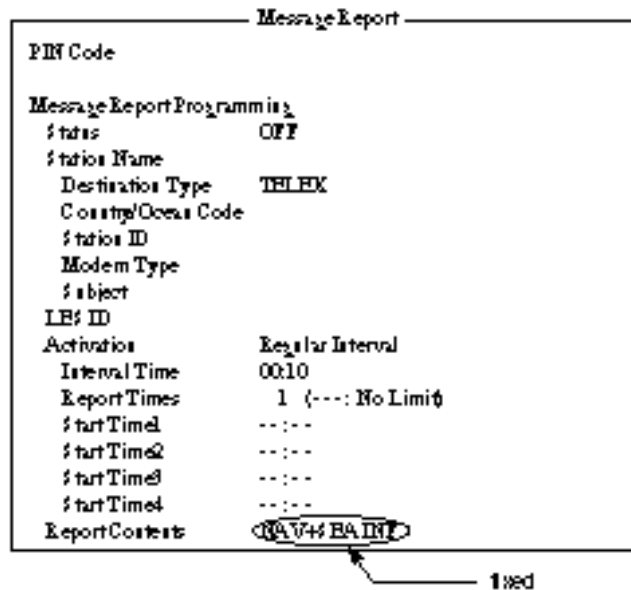

Figure 5-5 Message report menu

3. Press [Enter] to open the window for PIN code entry.
4. Key in the PIN code.  
PIN code (max. 8 digits) should be agreed upon with your recipient beforehand.
5. Press [Enter] to close the window.
6. Press [↓].
7. Press [Enter] to open the selection window.
8. Select “ON” or “OFF”.  
ON: Message report on  
OFF: Message report off
9. Press [Enter] to close the selection window.
10. Press [↓].
11. Press [Enter] to display the station list.
12. Select a station.

13. Press [Enter] to close the station list.
14. Press [ ↓ ] to place the cursor on the LES ID line.
15. Press [Enter] to display the LES list.
16. Select LES.
17. Press [Enter] to close the LES list.
18. Press [ ↓ ].
19. Press [Enter] to open the selection window.
20. Select “Regular Interval” or “Daily”.
21. Press [Enter] to close the selection window.
22. Press [ ↓ ].
  - When “Regular Interval” is selected on step 20,
    - (1) Press [Enter] to open the window for interval time entry.
    - (2) Key in the interval time.
    - (3) Press [Enter] to close the window.
    - (4) Press [ ↓ ].
    - (5) Press [Enter] to open the window for report times entry.
    - (6) Key in the report times or select “No Limit”.
    - (7) Press [Enter] to close the window.
  - When “Daily” is selected on step 20,
    - (1) Press [Enter] to open the window for start time entry.
    - (2) Key in the start time.
    - (3) Press [Enter] to close the window.
    - (4) Press [ ↓ ].
    - (5) If necessary, key in the start time of Start Times 2-4.

23. Press [Esc] to register the above settings.

Message Report	
PIN Code	12345678
Message Report Programming	
Status	ON
Station Name	FENINMBTSTSE
Destination Type	TELEX
Country/Ocean Code	583
Station ID	343199710
Modem Type	
Subject	
LE# ID	303 (YAMAGUCHI)
Activation	Daily
Interval Time	01:00
Report Times	24 (---: No Limit)
StartTime1	08:00
StartTime2	--:--
StartTime3	--:--
StartTime4	--:--
Report Contents	NAV+BAINT

Entry

---

Yes | No

Figure 5-6 Message Report Screen

24. Select "Yes".

25. Press [Enter] to finish.

## Polling

When the FELCOM 12 receives a polling command from your home office, it automatically transmits data to your home office. The data are position, speed, bearing and other data sent from a navigational equipment or an interface unit.

A polling command from your home office can also activate data report or message report if the corresponding setting is completed on the FELCOM 12. If a polling command with a file name is received, the FELCOM 12 transmits the file to your home office.

### Polling command

This paragraph shows you how to make the polling command **at your home office**.

There are two kinds of polling commands: one is sent on the MES signalling channel and the other is sent on the MES message channel.

#### Polling command on MES signalling channel

Request a land station to make the polling command because the format varies with land station.

## Polling command on MES message channel

To make the polling command, enter D???, hyphen, PIN code (max. 8 digits), hyphen, file name (stored in the floppy disk of the FELCOM 12), colon and text of message.

To send file data, type a hyphen and file name. If no hyphen and file name is entered, MES automatically transmits nav data (own ship position, course, speed, etc). For PIN Code setting refer to page 5-4.

```
D???-PIN code-file name: (text of message)
```

*Figure 5-7 Polling command*

## Polling reception

No operator intervention is required during polling reception.

The printer PP-510 prints the status of polling reception and data transmission in response to polling request as shown below.

```
-----  
Receive Message  
  
Message No.      : R0990907.002  
Message Ref. No. : 00616923  
LES             : YAMAGUCHI  
Priority         : Normal  
Message Size    : 121 characters  
Receive Data & Time : 99-09-09 04:07 (UTC)  
  
KDD INMARSAT-C SERVICE 9-SEP-1999 04:02:28 UTC REF:616923  
XXXXXXXXXX ABCD X via YAMAGUCHI LES  
  
D???-12345678:test test  
  
-----  
  
99-09-09 04:09 (UTC)  
Successful Sending message.  
  
-----  
Sent Message  
DELIVERY CONFIRMATION OFF  
  
Message File   : Report           Message Size : 284 characters  
LES           : YAMAGUCHI        Date       : 99-09-09  
Priority       : Normal           Time       : 04:09 (UTC)  
Destination   : TELEX           582 (IA5)  
  
582+  
Date & Time    99-09-09 04:07 (UTC)  
Position      LAT 12:34.56N      Water Temp  32.1  
              LON 123:45.67E    Water Current 22.3 KTS  
Course        321.1              111.0  
Speed         1.1 KTS           Depth      123.4FT  
  
-----
```

*Figure 5-8 Sample MES message channel printout*

# DNID (Data Network Identification)

When you make a contract with an information provider, DNIDs are downloaded from the information provider to your FELCOM12 via an LES.

Up to 64 DNIDs can be downloaded to the FELCOM 12.

## Displaying DNID

1. Press [F5] to display the Position Reports menu.
2. Press [3] to display the Data Network ID screen.

Data Network ID						
RET: Activate SPACE: Inhibit Ctrl+P: Print ESC: Quit						
Mark "*" means activation.						
No.	Act	DNID	LES	Subaddr	Member	Text
01	*	00004	101	000	001	
02	*	00004	101	002	003	
03	*	23456	101	002	223	
04	*	03333	101	002	044	
05	*	03333	101	000	044	
06	*	07777	101	000	099	
07	*	09999	101	000	088	
08						
09						
10						

Figure 5-9 Data network ID menu

**Note:** DNID with "\*" mark are available for use(Refer to Figure 5-10).

```

-----
POLLING Message --- Program Unreserved Data Reporting ---
DNID :0004 LES ID :101 (Southbury)
Sub Address :000 Member Number :001 Response: No Response
Receive Data & Time: 97-04-15 00:01 (UTC)

Start Frame: 00030 Interval: 00030
-----
97-04-15 00:01 (UTC)
Data Report Program has been initiated by Polling.

-----
POLLING Message --- Initiate Unreserved Data Reporting ---
DNID :0004 LES ID :101 (Southbury)
Sub Address :000 Member Number :001 Response: Data Report
Receive Data & Time: 97-04-15 00:01 (UTC)

Start Frame: 00030 Interval: 00030
-----
Data Reported (Poll Response)
LES :Southbury Date :97-04-15
DNID :0004 Time :00:03 (UTC)
Member No. :001

Position LAT 10:14.03N
LON 124:36.81E
-----
97-04-15 00:06 (UTC)
Successful Data Report Sending.

```

Figure 5-10 Sample MES signalling channel printout



## Enabling/Disabling DNID

DNID can be enabled or disabled as follows:

1. Press up/down arrow key to place the cursor on the desired DNID.
2. Press [Enter] to enable the DNID. (\* mark appears.)  
Press [Enter] to disable the DNID. (\* mark disappears.)

**Note:** *When a DNID is disabled “running data program (poll)” is displayed and polling is cancelled.*

3. Press [Esc] to close the window.
4. To return to the standby display, press [Esc] twice.

**Note:** *“Disable” not permitted in FFA version.*

This page is intentionally left blank.

# DISTRESS ALERT

## Preparing a Distress Alert

1. Press [F8] to display the Setup menu. Note that this key has precedence over any operation.
2. Press [1] to display the Distress Message Setup screen.

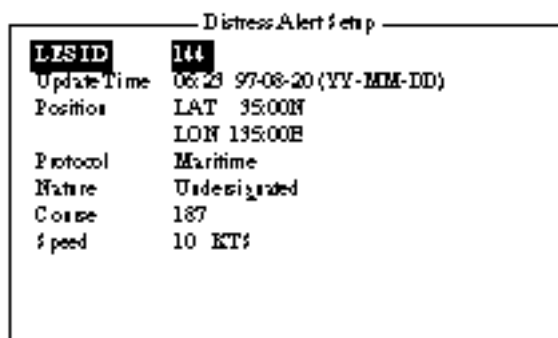

Figure 6-1 Distress Alert setup screen

3. The default LES ID is 144, AOR-E, NCS. To change, press [Enter] to display the LES ID list. Select a suitable LES and press [Enter].
4. Press [↓] to select Update Time. Enter the time (hours and minutes and date) if necessary. The time indication stays still showing the last update. Current time and position are shown at the bottom right on the screen.
5. Press [↓] to select Position.
6. Press [Enter] to open the window for position entry.
7. Enter position in latitude and longitude. Use [→] to shift the cursor from degree to minutes and co-ordinate. Enter co-ordinate with appropriate alphabet key.
8. Press [Enter] to close the window.
9. Press [↓] to advance the cursor to the Protocol line.
10. For marine vessels Protocol should be set to Maritime.

11. Press [ ↓ ] to select Nature. Press [Enter] to display the list. Select appropriate nature of distress.

- |                |                             |
|----------------|-----------------------------|
| Undesignated   | Listing                     |
| Fire/Explosion | Sinking                     |
| Flooding       | Disabled & Adrift           |
| Collision      | Abandoning ship             |
| Grounding      | Further assistance required |
|                | Piracy or Armed Attack      |

If nature of distress is not specified, “Undesignated” is automatically selected.

12. Press [Enter] to close the list.

13. Press [ ↓ ] to go to the Course and/or Speed entry. Enter course and/or speed if they are different from what appears on the screen.

14. Press [Esc]. You are now asked to update data entered.

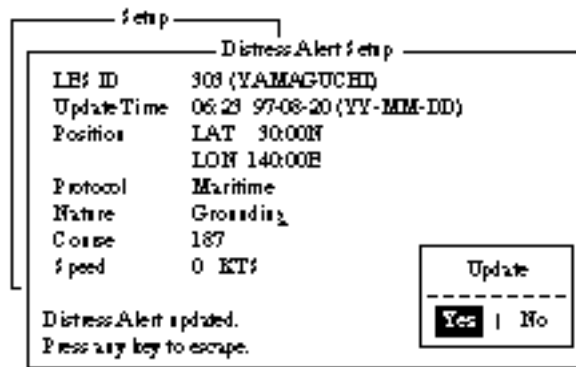

\*Current update is shown at the position display of the bottom right corner.

*Figure 6-2 Distress Alert setup, requesting confirmation of settings*

15. Press [Enter] to register data you’ve just entered.

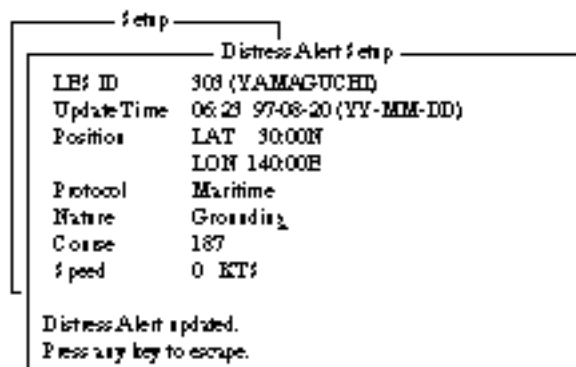

*Figure 6-3 Distress Alert setup, distress alert updated*

## Transmitting a Distress Alert

1. Open cover on DISTRESS button.
2. Press the DISTRESS button 4 seconds on Distress Alert Unit IC-302.

**Note:** *Within 3 seconds, the distress alert will not be transmitted.*

The lamp inside the button flashes quickly and an audible alarm sounds intermittently. Four seconds later, the distress alert is transmitted and light the lamp and an audible alarm sounds continuously. When you receive acknowledgment of the distress alert from an LES, the lamp flashes slowly and the audible alarm sounds intermittently.

To silence the audible alarm, press [F10].

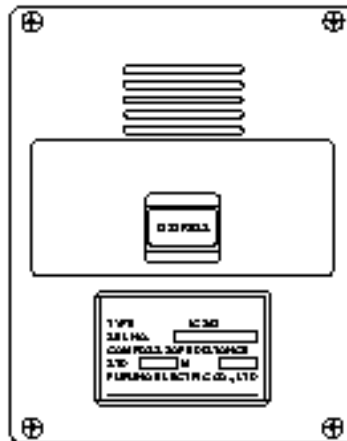

Figure 6-4 Distress Alert Unit IC-302

Do not press the button to silence an alarm for incoming distress or urgent message. This will transmit a distress alert for own ship.

## Testing Distress Button

The DISTRESS button on the IC-302 may be tested without transmitting the distress signal as follows:

1. Press [F7] to display the Options menu.
2. Press [6] to display the Test menu.

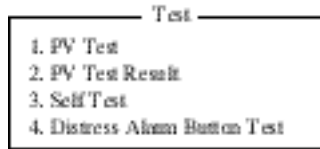

*Figure 6-5 Test Menu*

3. Press [4].
4. Press [Enter]. The Distress Alert Button Test mode screen appears.

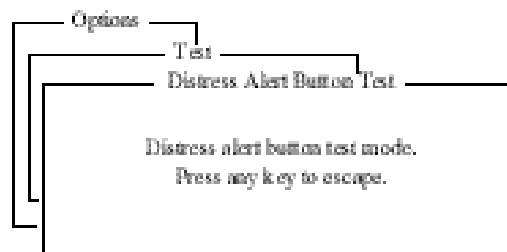

*Figure 6-6 Distress alert button mode screen*

5. Open cover on DISTRESS button.
6. Press the DISTRESS button 4 seconds.
7. Confirm that the IC-302 sounds the audible alarm.
8. Close the cover on DISTRESS button.
9. Press any key to escape.

# Distress Communications

The **distress alert** provides the minimum distress reporting requirements: own vessel's ID, speed, course, L/L position and nature of distress. After receiving the distress alert acknowledgment and you are not pressed for time you may send detailed information as follows:

1. Press [F1] followed by [Enter] to display the editor screen.
2. Prepare distress communication message. Figure 6-7 shows a sample distress message.

```
MAYDAY MAYDAY MAYDAY
THE NAME IS ..... Ship's name
IN NEED HELP ..... : Type of assistance required
```

Figure 6-7 Sample distress message

3. Press [F3].
4. Press [Enter]. The screen should look something like Figure 6-8. The cursor is on the Priority line.

```
Transmit ----- [-[1] UNTITLED1]-
Transmit Message -----
Priority          Normal
Message File     Message now being edited      size 63
Station Name
Destination Type TELELEX
Prefix Code
Country/Ocean Code
Station ID
Modem Type
Address
Subject
Attach File
LES ID
Option
[ TRANSMIT ]
```

Figure 6-8 Transmit message screen

5. Press [Enter] to open the selection window.
6. Press [ ↓ ] to select "Distress".
7. Press [Enter] to close the selection window.
8. Press [ ↓ ] to go the LES ID line.
9. Press [Enter] to open the LES list.
10. Select the LES where the distress alert was transmitted.

11. Press [Enter] to close the LES list.
12. Press [ ↓ ] to place the cursor on TRANSMIT.
13. Press [Enter]. The display should look similar to Figure 6-9.

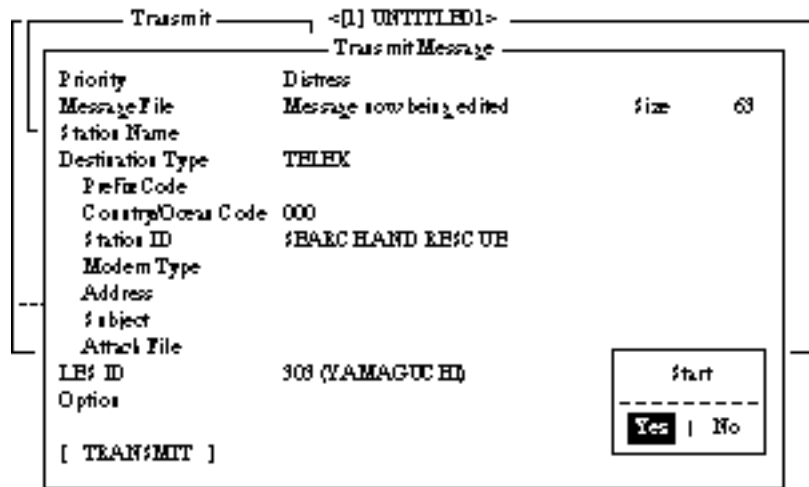

Figure 6-9 Transmit message screen with send start confirmation prompt

14. Press [Enter] to transmit the distress message to the LES.

**Note:** Country/Ocean Code and Station ID are not required in a distress message.



# OTHER FUNCTIONS

This chapter describes how to abort operation, scan NCS and select EGC and NCS channels.

## Aborting an Operation

You can abort transmission, receiving or scanning during operation.

1. Press [F7] to display the Options menu.

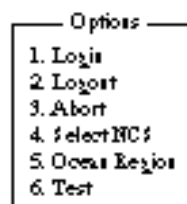

Figure 7-1 Options menu

**Note:** If the FELCOM 12 is set to operate as an EGC-only receiver, the menu looks like this:

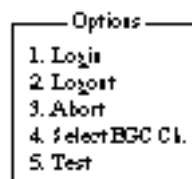

Figure 7-2 Options menu, EGC-only receiver status

2. Press [3] to select Abort.

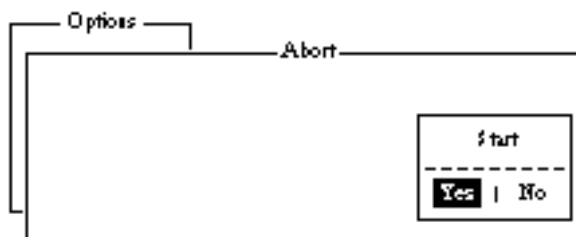

Figure 7-3 Abort screen

3. Press [Enter] to abort. (The message “Forced Clearing” replaces either Sending, Receiving or Scanning at the bottom of the screen.)

**Note:** Aborting is possible in sending, receiving or scanning. If attempted in other operating modes “Cannot abort current process.” appears.

# Scanning NCS

The communication unit automatically tunes itself to the NCS selected on the System Setup menu. You can, however, tune to another NCS which has a stronger signal. Scanning is possible only when the communication unit is IDLE and FELCOM 12 is set to operate as an Inmarsat-C transceiver.

If the communication unit is not idle, "Communication unit is not Idle now. Cannot start scan." appears. Press any key to escape then wait until the unit is in the idle state.

1. Press [F7] to display the Options menu.
2. Press [5] to display the Ocean Region screen.



Figure 7-4 Ocean region screen

3. The NCS you are currently tuned to appears in reverse indication. If necessary, select another NCS.
4. Press [Enter].

If Auto is selected, FELCOM 12 scans all NCSs in turn. If a particular ocean region is selected, FELCOM 12 scans all channels of that NCS. (NCSs will begin using multiple channels when the third generation satellites come into use.)

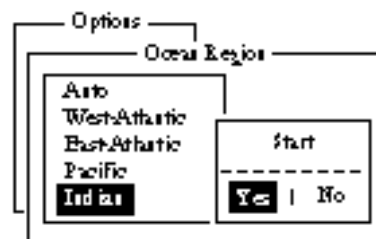

Figure 7-5 NCS scan confirmation screen

5. Press [Enter] to start the scanning.

*The message "Starting Scan Process. Press any key to escape." appears during the scanning.*

## Selecting EGC Receiving Channel

EGC channel can be selected when the DTE is set to operate as an EGC-only receiver. This procedure is shown for reference; currently there is only one EGC channel per NCS.

1. Press [F8] to display the Setup menu.
2. Press [9] to display the Configuration menu.
3. Press [3]. The EGC channel which the EGC receiver is currently tuned to appears on the display in reverse indication.

File	Edit	Transmit	EGC	Reports	logs	Options	Setup	Position	Stop/Alarm																																																																																																																																																																																																																																																										
-----																																																																																																																																																																																																																																																																			
<table border="1" style="width: 100%; border-collapse: collapse;"> <tr> <td colspan="4" style="text-align: center;">Setup</td> <td colspan="2"></td> <td colspan="2"></td> <td colspan="2"></td> </tr> <tr> <td colspan="4" style="text-align: center;">Configuration</td> <td colspan="2"></td> <td colspan="2"></td> <td colspan="2"></td> </tr> <tr> <td colspan="4" style="text-align: center;">EGC Channel List</td> <td colspan="2"></td> <td colspan="2"></td> <td colspan="2"></td> </tr> <tr> <td colspan="4"></td> <td colspan="2" style="text-align: center;">ENT: set</td> <td colspan="2" style="text-align: center;">ESC: quit</td> <td colspan="2"></td> </tr> <tr> <td style="text-align: center;">11090P</td> <td style="text-align: center;">12590P</td> <td style="text-align: center;">10940P</td> <td style="text-align: center;">11090P</td> <td colspan="2"></td> <td colspan="2"></td> <td colspan="2"></td> </tr> <tr> <td style="text-align: center;"> </td> <td style="text-align: center;"> </td> <td style="text-align: center;"> </td> <td style="text-align: center;"> </td> <td colspan="2"></td> <td colspan="2"></td> <td colspan="2"></td> </tr> <tr> <td style="text-align: center;"> </td> <td style="text-align: center;"> </td> <td style="text-align: center;"> </td> <td style="text-align: center;"> </td> <td colspan="2"></td> <td colspan="2"></td> <td colspan="2"></td> </tr> <tr> <td colspan="4"></td> <td colspan="2"></td> <td colspan="2"></td> <td colspan="2"></td> </tr> <tr> <td colspan="4">Current Channel</td> <td colspan="2">NCS 00</td> <td colspan="2">BBER</td> <td colspan="2">004</td> </tr> <tr> <td colspan="4">Current TDM</td> <td colspan="2">NCS 00</td> <td colspan="2">C/N</td> <td colspan="2">OK ( 39dB)</td> </tr> <tr> <td colspan="4">MES Status</td> <td colspan="2">Idle</td> <td colspan="2">Send Level</td> <td colspan="2">OK ( 0)</td> </tr> <tr> <td colspan="4">GPS Status</td> <td colspan="2">****</td> <td colspan="2">RXIF AGC Level</td> <td colspan="2">OK (134)</td> </tr> <tr> <td colspan="4">DCE Memory</td> <td colspan="2">32916 Bytes free</td> <td colspan="2">REF Offset Req</td> <td colspan="2">OK ( 0Hz)</td> </tr> <tr> <td colspan="4"></td> <td colspan="2"></td> <td colspan="2">Synthe 1st -1 Local</td> <td colspan="2">OK</td> </tr> <tr> <td colspan="4"></td> <td colspan="2"></td> <td colspan="2">1st -2 Local</td> <td colspan="2">OK</td> </tr> <tr> <td colspan="4"></td> <td colspan="2"></td> <td colspan="2">RX2nd Local</td> <td colspan="2">OK</td> </tr> <tr> <td colspan="4"></td> <td colspan="2"></td> <td colspan="2">Antenna Power Supply</td> <td colspan="2">OK</td> </tr> <tr> <td colspan="4"></td> <td colspan="2"></td> <td colspan="2">Water Temperature</td> <td colspan="2">DEG</td> </tr> <tr> <td colspan="4"></td> <td colspan="2"></td> <td colspan="2">Water Current</td> <td colspan="2">DEG</td> </tr> <tr> <td colspan="4"></td> <td colspan="2"></td> <td colspan="2">Direction</td> <td colspan="2">DEG</td> </tr> <tr> <td colspan="4"></td> <td colspan="2"></td> <td colspan="2">Speed</td> <td colspan="2">KTS</td> </tr> <tr> <td colspan="4"></td> <td colspan="2"></td> <td colspan="2">Depth</td> <td colspan="2"></td> </tr> <tr> <td colspan="10">-----</td> </tr> <tr> <td colspan="4" style="background-color: black; color: white;">Current State: EGC RECEIVER</td> <td colspan="2">SYNC (NCS)</td> <td colspan="2">97-09-21 02:00 (UTC)</td> <td colspan="2"></td> </tr> <tr> <td colspan="4">DCE Ver **</td> <td colspan="2">NCS: IDR LOGOUT</td> <td colspan="2">LAT: 00:00.00N</td> <td colspan="2">LON: 000:00.00E</td> </tr> </table>										Setup										Configuration										EGC Channel List														ENT: set		ESC: quit				11090P	12590P	10940P	11090P																																					Current Channel				NCS 00		BBER		004		Current TDM				NCS 00		C/N		OK ( 39dB)		MES Status				Idle		Send Level		OK ( 0)		GPS Status				****		RXIF AGC Level		OK (134)		DCE Memory				32916 Bytes free		REF Offset Req		OK ( 0Hz)								Synthe 1st -1 Local		OK								1st -2 Local		OK								RX2nd Local		OK								Antenna Power Supply		OK								Water Temperature		DEG								Water Current		DEG								Direction		DEG								Speed		KTS								Depth				-----										Current State: EGC RECEIVER				SYNC (NCS)		97-09-21 02:00 (UTC)				DCE Ver **				NCS: IDR LOGOUT		LAT: 00:00.00N		LON: 000:00.00E	
Setup																																																																																																																																																																																																																																																																			
Configuration																																																																																																																																																																																																																																																																			
EGC Channel List																																																																																																																																																																																																																																																																			
				ENT: set		ESC: quit																																																																																																																																																																																																																																																													
11090P	12590P	10940P	11090P																																																																																																																																																																																																																																																																
Current Channel				NCS 00		BBER		004																																																																																																																																																																																																																																																											
Current TDM				NCS 00		C/N		OK ( 39dB)																																																																																																																																																																																																																																																											
MES Status				Idle		Send Level		OK ( 0)																																																																																																																																																																																																																																																											
GPS Status				****		RXIF AGC Level		OK (134)																																																																																																																																																																																																																																																											
DCE Memory				32916 Bytes free		REF Offset Req		OK ( 0Hz)																																																																																																																																																																																																																																																											
						Synthe 1st -1 Local		OK																																																																																																																																																																																																																																																											
						1st -2 Local		OK																																																																																																																																																																																																																																																											
						RX2nd Local		OK																																																																																																																																																																																																																																																											
						Antenna Power Supply		OK																																																																																																																																																																																																																																																											
						Water Temperature		DEG																																																																																																																																																																																																																																																											
						Water Current		DEG																																																																																																																																																																																																																																																											
						Direction		DEG																																																																																																																																																																																																																																																											
						Speed		KTS																																																																																																																																																																																																																																																											
						Depth																																																																																																																																																																																																																																																													
-----																																																																																																																																																																																																																																																																			
Current State: EGC RECEIVER				SYNC (NCS)		97-09-21 02:00 (UTC)																																																																																																																																																																																																																																																													
DCE Ver **				NCS: IDR LOGOUT		LAT: 00:00.00N		LON: 000:00.00E																																																																																																																																																																																																																																																											

Figure 7-6 EGC channel list screen

4. Select desired channel.
5. Press [Enter] to start the tuning.
6. Press [Esc] to close the Update screen.
7. Press [Enter] to select "Yes".

## Selecting NCS Channel

NCS channel can be selected as shown in the procedure below. Currently, each satellite transmits one global beam. In the future, the satellites will transmit multiple spot beams, namely, the NCS will have multiple channels.

1. Press [F7] to display the Options menu.
2. Press [4] to display the Select NCS menu. The NCS Channel List appears.  
NCS channels programmed at page 2-16 appear on the list.

Options

1. LogIn

NCS Channel List

ENT: set ESC: quit

No	AOR (WEST)		AOR (EAST)		POR		DR	
	ID	FREQ	ID	FREQ	ID	FREQ	ID	FREQ
1	044	11090P	144	12390P	244	12390P	344	10940P
2	0		1		2		3	
3	0		1		2		3	
4	0		1		2		3	
5	0		1		2		3	
6	0		1		2		3	
7	0		1		2		3	
8	0		1		2		3	

Figure 7-7 NCS channel list

3. Select NCS channel.
4. Press [Enter].
5. Press [Esc] to close the Update screen.
6. Press [Enter] to select "Yes".  
The unit tunes to the channel selected.

# MAINTENANCE

This chapter provides the information necessary for the maintenance and checking of the FELCOM 12.

## Safety Information

**⚠ WARNING**

 **Do not open the cover of the equipment.**

This equipment uses high voltage electricity which can shock, burn, or cause serious injury. Only qualified personnel should work inside the equipment.

 **Hazardous microwave**  
**Do not approach within 60 cm of the antenna radome when it is transmitting.**

Microwave radiation can be harmful to the human body, particularly the eyes.

Radiation Level	At
10 W/m <sup>2</sup>	60 cm

**Do not disassemble the equipment.**

Fire, electrical shock or serious injury may result.

# General Checking and Maintenance

Turn off the power before conducting any maintenance procedures other than the cleaning of the terminal unit and communication unit.

## Cleaning the terminal unit and communication unit

These units can be cleaned with a soft, dry cloth. DO NOT use chemical cleaners. They may remove paint and markings.

## Checking connectors and earth terminal

The connectors and earth terminal on the rear panel of the communication unit and on the bottom panel of the terminal unit should be checked periodically for tightness. If the earth terminal has rusted, clean it.

## Floppy disk drive head

The floppy disk is coated with a magnetic material which stores information entered into the disk. If this material is damaged by foreign material adhering to the disk drive head it may not be possible to read from or write to the disk. Clean the head regularly with a cleaning floppy disk to prevent loss of data.

## When the power can't be turned on (power lamp does not light)

3) and 4) are for service technicians.

- 1) Check the power cable connector on both the rear panel of the terminal unit and communication unit for tightness. Check if the ship's mains switchboard is turned on.
- 2) On the terminal unit, check the breaker on the rear panel. If it has tripped it will be protruding several millimeters. Reset it if necessary.
- 3) On the rear panel of the terminal unit, disconnect the power cable. Connect a multimeter to the power cable connector and confirm 21.6 and 31.2 V. (pin #1: positive, pin #2: negative)
- 4) On the rear panel of the communication unit, disconnect the power cable. Connect a multimeter to the power cable connector and confirm 21.6 and 31.2 V. (pin #1 and #2: positive, pin #3 and #4: negative)

# Self Tests

The communication unit and the terminal unit are equipped with self tests which check them for proper operation.

## Self test at power application (communication unit)

The communication unit performs the following tests when it is turned on:

- a) ROM sum test
- b) RAM read and write test
- c) DP RAM read and write test
- d) EEPROM sum test
- e) VITERBI decoder test

If the unit finds no fault it goes into normal operation.

## Testing the communication unit through the keyboard

This test can only be initiated from the main DTE. The communication unit must be idle.

1. Press [F7] to display the Options menu.
2. Press [6] to display the Test menu.
3. Press [3]. The Communication Unit (self test) screen appears.

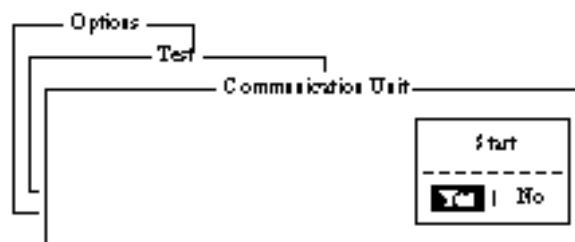

Figure 8-1 Communication unit screen

4. Press [Enter] to start the test.

The message “Now Communication Unit-testing” appears in blinking reverse video during testing.

- When the test is completed the screen shows the results of the test.

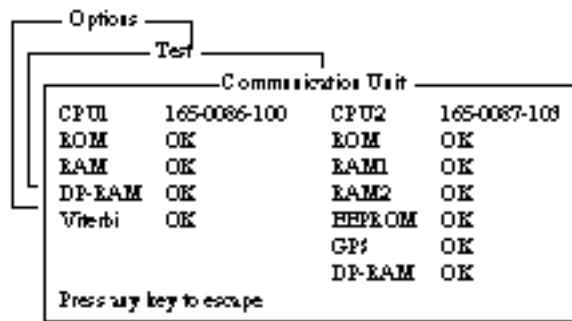

Figure 8-2 Sample communication unit self test results

Either “OK” or “NG” (No Good) appears next to each ROM and RAM tested. NG display releases the audible alarm. For defective ROM, RAM, DP-RAM, EEPROM or VITERBI replace the CPU Board. For GPS, NG appears when there is no GPS board or it is faulty.

- Press any key to finish the communication unit test.

## Performance Verification (PV) Test

After the FELCOM 12 is installed, the installing technician usually confirms that the unit is functioning properly and is logged in with the Inmarsat C system by conducting the PV test.

The PV test consists of the message reception test, message transmission test and distress alert test.

The results of the test appear on the PV test result display.

Note that the test cannot be conducted from a 2nd DTE. Note also that the test can be initiated by a LES.

### PV test sequence

- Select PV Test on the Test menu.
- The NCS acknowledges request for testing.
- The MES, upon receiving acknowledgment from NCS, goes into pending state.
- NCS will select a (not busy) LES to perform the test.
- The LES transmits a test message to the MES.
- MES transmits a test message to the designated LES.
- LES receives test message.



8. The MES automatically transmits the distress alert test within two minutes after completion of step 8.
9. When the distress alert test is finished the results of the test are sent to MES.

**The entire PV test can be conducted automatically (taking about 15 minutes in total).**

## PV test procedure

1. Confirm that the communication unit is in idle condition and logged in.
2. Press [F7] to display the Options menu.
3. Press [6] to display the Test menu.
4. Press [1] to select PV Test.

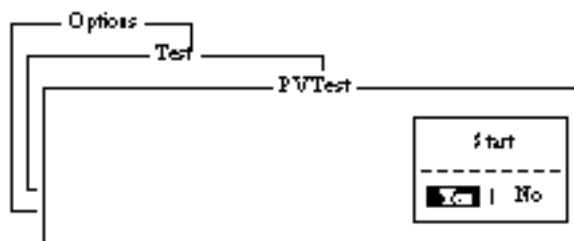

Figure 8-3 PV test screen

**Note:** If the communication unit is not idle when the test is initiated the screen displays “MES is not idle now. Cannot start PV Test.” And if not logged in, “Cannot start PV Test. (not Logged-in)” appears.

5. Press [Enter] to transmit the PV test request to NCS.

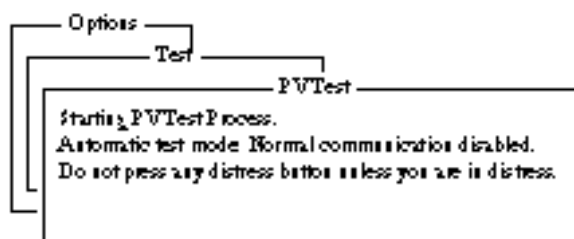

Figure 8-4 PV test screen

6. Press [Esc] to return to the standby display.
7. The screen displays “Current State: Idle (pending!)” when the acknowledge signal is received from the NCS.
8. When testing begins the screen displays “Current State: TESTING”.
9. Transmit a message to the LES. The LES, after acknowledging receipt of your message, transmits a message to you.

10. Though a prompt asks you to test distress alert, do not press any key. The alert test is automatically conducted two minutes later.
11. When testing is completed the indication TESTING is replaced by IDLE.
12. The test results appear on the PV Test Result screen. (The next section shows how to interpret the results.)

## Results of PV test

1. At the standby display, press [F7] to display the Options menu.
2. Press [6] to display the Test menu.

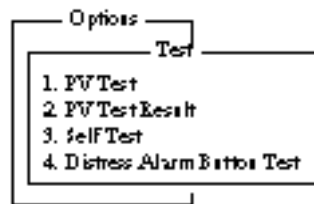

Figure 8-5 Test menu

3. Press [2] to display the results of the PV test.

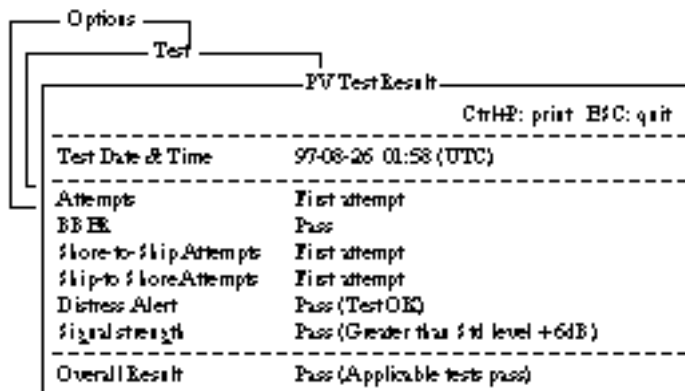

Figure 8-6 Sample PV test results

**Note:** If the communication unit is off or malfunctioning, “DCE error: No response from DCE!!” appears. Check the connection between the communication unit and the terminal unit.

4. To escape, press any key. The standby display appears.

## Interpreting the PV tests results display

- Test Date & Time:** Date and time of test
- Attempts:** Number of times the PV test was conducted.

- BBER:** Bulletin Board Error Rate (%). Pass appears for no error.
- Shore-to-Ship Attempts:** Number of tests initiated by LES.
- Ship-to-Shore Attempts:** Number of tests initiated by MES.
- Distress Alert:** "Pass (Test OK)" appears for successful testing.
- Signal Strength:** "Pass" appears if signal strength is greater than standard level.
- Overall Result:** "Pass" appears for satisfactory completion of test.

## System Status Monitor

The system status monitor, which is always displayed, provides date, time, equipment status and navigation data on one screen.

File	Edit	Transmit	BGC	Reports	logs	Options	Setup	Position	StopAlarm
Date			97-08-21			BBER		004	
Time			06:12(UTC)			C/N		OK( 38dB)	
						Send Level		OK( 0)	
Position			LAT 35:00.00N			RxIFAGC Level		OK(133)	
			LON 135:00.00E			RHF Offset Freq		OK( 0Hz)	
Waypoint			LAT			Synthe 1st1 Local		OK	
			LON			1st2 Local		OK	
Course			DBG			RX2nd Local		OK	
Speed			KT%						
CurrentNC%			344 (DE)	LOGIN		Antenna Power Supply		OK	
CurrentChannel			LB% TDM						
CurrentTDM			LB% TDM			Water Temperature		DBG	
ME% Status			Busy			Water Current			
GP% Status			----			Direction		DBG	
						Speed		KT%	
DCE Memory			32818 Bytes Free			Depth			
-----									
Current State:	TESTING					YNC (LB%)		97-08-21 06:12(UTC)	
TEST-RECEIVING	ME%AGE					NC%: IOK	LOGIN	LAT: 35:00.00N	
DCE Ver	03 Oct1996							LON 135:00.00E	

Figure 8-7 System status monitor display

## Interpreting the system status monitor

<b>Date:</b>	Current date
<b>Time:</b>	Current time
<b>Position:</b>	Vessel's position (either manual entry or automatic input by navigation aid)
<b>Waypoint:</b>	Destination
<b>Course:</b>	Heading
<b>Speed:</b>	Ship's speed
<b>Current NCS:</b>	NCS your vessel is logged in with
<b>Current Channel:</b>	Channel in use
<b>Current TDM:</b>	Channel TDM
<b>MES Status:</b>	Operational status of MES
<b>GPS Status:</b>	Receiving signal status from GPS receiver. CST: Cold Start ACK: Acquired; Almanac data acquired IMP: Impossible; cannot receive GPS signal INT: Interrupted; object interfering reception of GPS signal ALM: Receiving the almanac 2D, 3D: Position-fixing method by 2 or 3 dimension

*Note: The above status indication depends on the GPS receiver connected.*

<b>DCE memory:</b>	Memory remaining in communication unit
<b>BBER:</b>	Bulletin Board Error Rate (%)
<b>C/N:</b>	Check of circuit status with LES, receiving circuit in antenna unit, RF CON Board and CPU Board (DEMOD section). OK appears for figure greater than 31.
<b>Send Level:</b>	TX level check. At transmission, OK appear for more than 123. At reception OK appears for figure less than 32.
<b>RX IF AGC Level:</b>	Check the receiving circuit of the antenna unit and the RF CON Board in the communication unit. OK appears for figure greater than 80.

<b>REF Offset Freq:</b>	Operating normally. If it does not light check RX Synthesizer or REF OSC in the RF CON Board. OK appears for figure less than 150.
<b>Synthe 1st Local:</b>	Check of RF CON Board.
<b>RX 2nd Local:</b>	Check of RF CON Board 2nd local oscillator.
<b>Antenna Power Supply:</b>	NG appears for discontinuity or short in cable.
<b>Temperature*:</b>	Water temperature
<b>Water Current*</b>	
<b>Direction:</b>	Tidal current direction
<b>Speed:</b>	Tidal current speed
<b>Depth*:</b>	Depth of water

*Note: \* requires data from the navigation device.*

## Replacing Internal Battery

A lithium battery in the communication unit is used to backup system settings. The life of this battery is about five years, however actual life depends on usage when the battery is dead the communication unit automatically reverts to default system settings. Contact your dealer to request replacement of the battery.

Name: BTT(L1)  
Code No.: 000-103-769  
Type: CR1/2 8.L-F

This page is intentionally left blank.

## International Telex/Telephone Country Code List

Area and Country	Telephone Country Code	Telex Country Code	Remarks for Telex Code
Afghanistan	93	79	
Alaska	1	200	
Albania	355	604	
Algeria	21	408	
American Samoa	684	770	
American Virgin Is.	1	208	Telex calls to former WUI subscribers, insert the figure "9" after the destination code "208".
Andorra	33	590	
Angola	244	991	
Anguilla	1	391	
Antigua & Barbuda	2	393	
Argentina	54	33	Disregard the figure "0" at head of subscriber number.
Armenia	7	684	
Aruba	297	303	Subscriber numbers are 2XXXX or 5XXXX
Ascension	247	939	Manual calls 3XXXX
Australia	61	71	
Australian External Territories	672	766	
Austria	43	47	
Azerbaijani	994	784	
Azores Is.	351	404	Destination code is the same as for Portugal.
Bahamas	1	297	
Bahrain	973	490	
Bangladesh	880	780	
Barbados	1	392	
Belarus	7	681	
Belgium	32	46	
Belize	501	371	
Benin	229	972	
Bermuda	1	290	
Bhutan	975	890	
Bolivia (Rep. of)	591	371	
Bolivia (ENTAL)		309	
Bosnia-Herzegovina	387	600	
Botswana	267	962	
Brazil	55	38	Disregard the figure "0" at head of subscriber number.
British Virgin Is.	1	292	
Brunei Darussalam	673	809	
Bulgaria	359	67	
Burkina Faso	226	978	
Burundi	257	903	

Area and Country	Telephone Country Code	Telex Country Code	Remarks for Telex Code
Cambodia	855	807	Kampuchea Rep.
Cameroon	237	970	
Canada	1	{ 21 26	Disregard the figure "0" at head of subscriber number.
Canary Is.	34	52	Destination code is the same as for Spain.
Cape Verde	238	993	
Cayman Is.	1	293	
Central Africa Rep.	236	971	
Chad	235	976	
Chile	56	34	{ TCH subscribers 2XXXXXX ENTEL subscribers 5XXXXXX TRA subscribers 3XXXXXX TECOM subscribers 6XXXXXX YTR CM subscribers 4XXXXXX
China	86	85	
Christmas Is. (Aus)	672	766	
CIS (formerly USSR)	7	64	
Cocos-Keeling Is.	672	766	
Colombia	57	35	Disregard the figure "0" at head of subscriber number.
Comoros	269	994	Manual calls
Congo	242	981	
Cook Is.	682	772	
Costa Rica	506	376	
Cote d' Ivoire	225	983	Ivory Coast
Croatia	385	599	
Cuba	53	28	
Cyprus	357	605	
Czechoslovakia	42	66	
Denmark	45	55	
Diego Garcia	246	938	
Djibouti	253	979	
Dominica	1	394	
Dominican Rep.	1	{ 201 202 241	RCA subscribers 4XXXXXX For subscriber number beginning with 346, disregard "346" at head of subscriber number. AGEM IR subscribers 61XX
Ecuador	593	308	
Egypt	20	91	
El Salvador	503	373	
Estonia (formerly USSR)	372	537	
Ethiopia	251	980	



Area and Country	Telephone Country Code	Telex Country Code	Remarks for Telex Code
Falkland Is. (Malvinas)	500	306	
Faroe Is.	298	502	
Fiji	679	701	
Finland	358	57	
France	33	42	
French Guiana	594	300	
French Polynesia	689	702	
Gabon	241	973	
Gambia	220	996	
Georgia	7	683	
Germany (Fed, Rep. of)	49	{ 69 { 41 94	formerly East Germany
	49		formerly West Germany
Ghana	233		
Gibraltar	350	405	
Greece	30	601	
Greenland	299	503	
Grenada	1	395	
Guadeloupe	590	299	
Guam (RCA)	671	700	
Guatemala	502	372	
Guiana	594	300	
Guinea Conakry	224	995	Manual calls
Guinea Bissau	245	969	
Guyana	592	295	
Haiti	509	203	RCA subscribers 9XXX
		{ 704 { 705 { 708 { 709 (773)	RCA subscribers 8XXX or 2968XX
			ITT subscribers 743XXX
Hawaii	1		WUI subscribers 63XXX or 63XXXX
			WUH subscribers 39XXXX
			Telex calls to HTC subscribers can be made using Semi-automatic calls.
Honduras	504	374	
Hong Kong	852	802	
Hungary	36	61	
Iceland	354	501	
India	91	81	
Indonesia	62	73	Disregard the figure "0" at head of subscriber number.
Iran	98	88	
Iraq	964	491	
Ireland	353	500	
Israel	972	606	Disregard the figure "0" at head of subscriber number.
Italy	39	43	

Area and Country	Telephone Country Code	Telex Country Code	Remarks for Telex Code
Jamaica	1	291	
Japan		72	KDD (for 5 digits)
	81	720	NTT
Jordan	962	493	
Kazakhstan	7	785	
Kenya	254	987	
Kiribati	686	761	Subscriber numbers are 770XX
Korea (Demo, People's Rep. of)	850	(899)	
Korea (Rep. of)	82	801	
Kuwait	965	496	
Kyrgyzstan	7	788	
Lao	856	804	
Latvia (formerly USSR)	371	538	
Lebanon	961	494	
Lesotho	266	963	
Liberia	231	997	
Libya	21	901	
Liechtenstein	41	45	
Lithuania (formerly USSR)	370	539	
Luxembourg	352	402	
Macao	853	808	
Macedonia	389	597	
Madagascar	261	986	Subscriber number beginning with 4, 5, 7, 8 and 9 can be reached by Manual Calls.
Madeira Is.	351	404	Destination code is the same as for Portugal.
Malawi	265	904	
Malaysia	60	84	
Maldives Is.	960	896	
Mali	223	985	
Malta	356	{ 406 403	Subscriber number beginning with 11XX can be reached by Semi-automatic calls.
Mariana Is.	671	760	
Marshall Is.	692	765	
Martinique	596	298	
Mauritania	222	974	
Mauritius	230	966	
Mexico	52	22	Disregard the figure "0" at head of subscriber number.
Micronesia	691	764	
Moldova	373	682	
Monaco	33	42	Destination code is the same as for France.
Mongolia	976	800	

Area and Country	Telephone Country Code	Telex Country Code	Remarks for Telex Code
Montserrat	1	396	
Morocco	21	407	
Mozambique	258	992	
Myanmar (formerly Burma)	95	83	
Namibia	264	908	
Nauru	674	775	
Nepal	977	891	
Netherlands	31	44	
Netherlands Antilles	599	390	
New Caledonia	687	706	
New Zealand	64	74	
Nicaragua	505	375	
Niger	227	975	2XXXX other numbers are for Semi-automatic calls.
Nigeria	234	905	
Niue Is.	683	776	
Northern Mariana Is.	670		
Norfolk Is.	672	766	
Norway	47	56	
Oman	968	498	
Pakistan	92	82	
Palau	680	763	
Panama	507	377	TRT subscribers
		378	AACR subscribers
		379	INTEL subscribers
Papua New Guinea	675	703	
Paraguay	595	305	
Peru	51	36	
Philippines	63	75	PH LCOM subscribers 2XXXX
			RCPI subscribers 7XXXX
			GMCR subscribers 4XXXX
			ETPI subscribers 6XXXX
			CAPWIRE subscribers 1XXXX
			For PTT subscribers, insert the figure "8" after the destination code "75".
Poland	48	63	Disregard the figure "0" at head of subscriber number.
Portugal	351	404	
Puerto Rico	1	205	RCA subscribers 2XXX
		206	ITT subscribers 345XXXX
		207	C&W, WUI subscribers
		209	AC PR (PRCA) subscribers
Qatar	974	497	

Area and Country	Telephone Country Code	Telex Country Code	Remarks for Telex Code
Reunion	262	961	Subscriber numbers are 916XXX
Romania	40	65	Disregard the figure "0" at head of subscriber number.
Russian Federation	7	64	
Rwanda	250	909	
Saipan	670	760	
San Marino	378	505	
Sao Tome & Principe	239	967	Manual calls
Saudi Arabia	966	495	
Senegal	221	906	
Seychelles	248	965	
Sierra Leone	232	998	
Singapore	65	87	
Slovak	42	66	
Slovenia	386	598	
Solomon Is.	677	778	
Somalia	252	900	
South Africa	27	95	{ Cape Town subscribers XXXXXX Bophuthatswana subscribers 08XXXX Transkei subscribers 09XXXX
Spain	34	52	
Spanish North Africa	34	52	
Sri Lanka	94	803	
St. Helena	290	(960)	Manual calls 4XXX
St. Kitts & Nevis	1	397	
St. Lucia	1	398	
St. Pierre & Miquelon	508	204	
St. Vincent & the Grenadines	1	399	
Sudan	249	984	
Suriname	597	304	
Swaziland	268	964	
Sweden	46	54	
Switzerland	41	45	
Syria	963	492	
Tajikistan	7	787	
Taiwan	886	769	
Tanzania	255	989	
Thailand	66	86	
Togo	228	977	
Tokelau	690	762	
Tonga	676	777	
Trinidad & Tobago	296	294	
Tunisia	21	409	
Turkey	90	607	
Turkmenistan	7	789	

Area and Country	Telephone Country Code	Telex Country Code	Remarks for Telex Code
Turks & Caicos Is.	1	296	
Tuvalu	688	774	
U. A. E.	971	893	
Abu Dhabi			2XXXX, 3XXXX, 5XXXX
Ajman			695XX
Dubai			4XXXX
Fujairah			8XXXX
Ras Al Khaimah			9XXXX
Sharjah			68XXX
Umm Al Qaiwain			697XX
Uganda	256	988	
Ukraine	7	680	
United Kingdom	44	51	
United Arab Emirates	971	893	
Upper Volta	226	978	Same as "Burkina Faso".
Uruguay	598	32	
Uzbekistan	7	786	
U. S. A.	1	23	CCI subscribers 7XXXXXX ITT subscribers 4XXXX, 4XXXXXX, 4XXXXXXXXXX RCA subscribers 2XXXXX WUI subscribers 6XXXX, 6XXXXX, 6XXXXXX TRT subscribers 1XXXXX, 1XXXXXXXXXX FTCC subscribers 8XXXX, 8XXXXX GR PHNET subscribers 36XXXXX, 37XXXXX For WUT subscribers, insert the figure "0" after the destination code "23".
U. S. A. (Mainland)		23	
		25	Telex calls to TWX subscribers whose numbers do not contain "0" as the third figure of the 10 figure code can be made as Semi-automatic calls.
U. S. S. R. (Former)	7	640	Russian Federation
Vanuatu	678	771	
Vatican	379	504	
Venezuela	58	31	
Viet Nam	84	805	Subscriber number beginning with 561XXX can be made using manual calls
Wallis & Futuna Is.	681	707	
Western Samoa	685	779	
Yemen (Rep. of)	969	806	Formerly Yemen (P. D. Rep. of)
Yugoslavia (Former)	967	895	Formerly Yemen (Arab Rep.)

<b>Area and Country</b>	<b>Telephone Country Code</b>	<b>Telex Country Code</b>	<b>Remarks for Telex Code</b>
Zaire	243	982	Telex calls to places other than Kinshasa Subscriber beginning with 2XXXXX can be made as Semi-automatic calls.
Zambia	260	902	
Zanzibar	259	990	
Zimbabwe	263	907	
<b>Ocean Area</b>	<b>Telephone Ocean Region Access Code</b>	<b>Telex Ocean Region Access</b>	<b>Remarks</b>
AOR-W	874	584	Atlantic Ocean-W
AOR-E	871	581	Atlantic Ocean-E
POR	872	582	Pacific Ocean
IOR	873	583	Indian Ocean

# International Telex Abbreviations

Abbreviation	Meaning
ADV	Advise
ACK	Acknowledge
AGN	Again
BI (GS)	Good bye
BK	I cut off.
CFN	Confirm
COL	Collation
CRV	How do you receive?
DER	Out of order
DWN	Down
EEE	Error
FM	From
GA	Go ahead.
MNS	Minutes
MOM	Wait (Waiting)
MUTI	Mutilated
NA	Correspondence to this subscriber is not admitted.
NC	No circuits
NCH	Subscriber's number has been changed.
NP	The called party is not or no longer is a subscriber.
NR	Indicate your call number.
OCC	Subscriber is engaged.
OK	Agreed.
P (or 0)	Stop your transmission.
PLS (PSE)	Please
PPR	Paper
P (RCD)	Received
RAP	I will call you again.
RD	Reed
RE	Referring to
RPT	Repeat
SRY	Sorry
SVP	Please
TAX	What is the charge?
TEST MSG	Please send a test message?
THRU	You are in communication with telex position
TKS (TNX)	Thanks
TLX	Telex

# Glossary of Acronyms

Acronym	Meaning
AOR-E	Atlantic Ocean Region-East
AOR-W	Atlantic Ocean Region-West
BB	Bulletin Board
BBER	Bulletin Board Error Rate
BPSK	Binary Phase Shift Keying
BS	Back Space
C/N0	Carrier to Noise Power Spectral Density
CNID	Close Network ID
CPU	Central Processing Unit
CSDN	Circuit Switched Data Network
DCE	Data Circuit Terminating Equipment
DP-RAM	Dual-Port Random Access Memory
DTE	Data Terminal Equipment
EGC	Enhanced Group Call
EIRP	Equivalent Isotropically Radiated Power
FD	Floppy Disk
GPS	Global Positioning System
G/T	Gain to Noise Temperature Ratio
HPA	High Power Amplifier
IA5	International Alphabet No.5
ID	Identity
IMO	International Maritime Organization
INMARSAT	International Mobile Satellite Organization
IOR	Indian Ocean Region
ISDN	Integrated Services Digital Network
ITA2	No.2 International Telegraphy Alphabet
ITU	International Telecommunications Union
LES	Land Earth Station
LNA	Low Noise Amplifier
MES	Mobile Earth Station
MSI	Maritime Safety Information
NAVAREA	Navigational Area
NAVTEX	MF Navigational Broadcast Service
NCS	Network Coordination Station
NMEA	National Maritime Electronics Association
OCC	Operation Control Center
PEP	Packet Error Probability
POR	Pacific Ocean Region
PSDN	Packet Switched Data Network
PSTN	Public Switched Telephone Network
PVT	Performance Verification Test
RAM	Random Access Memory
RCC	Rescue Coordination Center
ROM	Read Only Memory
SCC	Satellite Control Center
SFU	Store and Forward Unit
SOLAS	Safety of Life at Sea
TDM	Time Division Multiplex
TDMA	Time Division Multiple Access
UTC	Coordinated Universal Time
WMO	World Meteorological Organization



# International Telegraphy Alphabet

No.	FIGURES	LETTERS	No.	FIGURES	LETTERS
1	—	A	17	1	Q
2	?	B	18	4	R
3	:	C	19	'	S
4	+	D	20	5	T
5	3	E	21	7	U
6	□	F	22	=	V
7	■	G	23	2	W
8	▣	H	24	/	X
9	8	I	25	6	Y
10	BELL	J	26	+	Z
11	(	K	27	CARRIAGE RETURN	
12	)	L	28	LINE FEED	
13	.	M	29	LETTERS	
14	,	N	30	FIGURES	
15	9	O	31	SPACE	
16	0	P	32	BLANK	

## Error Messages and Alerts

**A file by that name already exists on FD.**

This message appears when you attempt to copy a file from the internal memory to a floppy disk and a file by that name already exists on the disk.

**Cannot use this LES. Please check network configuration.**

You input an invalid LES ID.

**Cannot abort current process.**

The terminal unit displays this message if you try to stop the DCE in operating condition other than sending, receiving or scanning.

**Cannot activate distress alert test.**

Distress alert testing cannot be done without permission from LES.

**Cannot enter this message to sending Queue.**

This message appears when a message is sent to the message queue and it is full (two messages maximum).

**Cannot start PV Test. (not Logged-in)**

You cannot start PV testing without first logging in.

**Cannot start to send. (EGC Receiver)**

Transmission is not possible when the FELCOM 12 operates as a EGC-only receiver.

**Cannot start to send. (not Logged-in)**

A message cannot be transmitted without first logging in.

**Close a file in use to make a new file.**

The working areas are full (capacity: two files). Close a file to load a file to a working area.

**Communication Unit is not Idle now. Cannot start login.**

Cannot login when the communication unit is not idle.

**Communication unit is not Idle now. Cannot start scan.**

This message appears when the FELCOM 12 operates as a EGC-only receiver and scanning is initiated when the communication unit is not idle. Wait until the unit is idle before starting scanning.

**Communication Unit is not Idle now. Cannot start logout.**

Cannot logout when communication unit is not idle.

**Current State : Idle (pending!)**

This message appears when a LES affirmatively acknowledges your request for PV testing.

**Current State : Testing** You will see this display during PV testing.

**DCE Error : No response from DCE!!**

This message appears when you try to display the PV test results and there was no response from the communication unit because it is off or its interconnection cable is disconnected or damaged.

**Distress Message updated. Press any key.**

This message appears after you have correctly updated the distress message.

**Distress Alert Acknowledgment Received**

This alert will appear when the LES transmits the distress acknowledge signal to your vessel.

**FD not inserted in drive.**

You need to insert a floppy disk into the drive.

**FD not inserted in drive. Press any key to escape.**

This message appears if you attempt to format a disk and there is no disk in the drive.

**File by that name already exists. OK to overwrite?**

This alert asks you if it is alright to write over an existing file name.

**Formatting Completed.** This alert appears upon completion of floppy disk formatting.

**Input Error : Message File**

You have manually input an invalid file name.

**Internal GPS unit failure.**

This message appears when the internal installed GPS unit is not working or is faulty. When the navigation port is not set to "INT", this message does not appear.

**Invalid Frequency Code.**

This message appears when a wrong frequency code is entered in the EGC Channel List or NCS Channel List.

**Invalid NCS ID Code.**

This alert appears when a wrong NCS ID code is entered.

**Loading**

Appears during loading of a file to a working area.

**Message file is too big (partial transmission possible).**

The size of the file you want to send is larger than 31,500 bytes. (The file can be sent, but only the first 32,000 bytes of information will be received.)

**Message is entered in sending buffer.**

Before a message is transmitted it is sent to the message queue. This alert informs you the message has been accepted by the message queue.

**Message Send failed.** Could no send message because of satellite malfunction, etc.

**Message Send pending.** All circuits occupied at LES.

**Message Send rejected.** This alert appears when the LES rejects a message because of unpaid subscriber's fee or other reasons.

**No response from communication unit!**

This message will appear if the communication unit is turned off or its interconnection cable is disconnected or damaged.

**Now Self-testing Terminal. (cannot abort)**

Appears during testing of terminal unit.

**Now printing**

Appears during printing.

**Now Formatting**

Appears during formatting of floppy disk.

**OK to delete file?**

This alert verifies if it is alright to delete a file.

**OK to format FD?**

This alert verifies if it is alright to format a floppy disk.

**Printer error!!**

The printer is off or malfunctioning.

**Request started**

This message appears when requesting delivery status of a message.

**SAVING**

You will see this message when saving a file.

**SES is not idle now. Cannot start PV Test.**

This message means you will have to wait until the communication unit is idle to start the PV test.

**Starting Scan Process Press any key to escape.**

This prompt appears before scanning NCS.

**Update error! Retry again. Press RET to update end.**

This message appears if the distress alert message was updated incorrectly.

## LES IDs List

LES menu	AOR West	AOR East	IOR	POR
Perth			322	222
Goonhilly	002	102	302	
NETELY/BY/TELEN				202
Aussaquel		121	321	
Burum	022			
Blaavand		131		
Eik/Telenor	004	104	304	
Sentosa			328	210
Tangua	014	114		
Odessa		107	307	
Maadi		103		
Arvi			306	
Umm al Aish		106		
Fucino		105	335	
Thermopylae		120	305	
Jeddah			315	
Yamaguchi	003	103	303	203
Santa Paula				201
Sintra		118		
Southbury	001	101		
Ata		110	310	
Kumsan			308	208
Raisting		115	333	
Beijing			311	211
Psary		116	316	
Boumehen			314	
Nonthaburi			319	
Station 12	012	112	312	212
Station 12/Telstra		122		

This page is intentionally left blank.

# SPECIFICATIONS OF THE GMDSS RADIO RACK CONSOLE RC-1500-1T

## 1. RACK CONFIGURATION

- |                            |                       |
|----------------------------|-----------------------|
| (1) SSB Radiotelephone:    | FS-1562-25 or FS-5000 |
| (2) DSC/Watch Receiver:    | DSC-60                |
| (3) NBDP Terminal:         | DP-6                  |
| (4) Inmarsat C MES:        | FELCOM 12             |
| (5) Printer                | PP-510 (2 sets)       |
| (6) AC/DC Change-over Unit |                       |
| Battery Charger            | BC-6158               |
| Power Source               | PR-850AR              |
| Duplex Battery             | PR-300                |

## 2. POWER SUPPLY

- |  |                                      |
|--|--------------------------------------|
| (1) Main Source/ Battery Charger Source: | 100 VAC, 1 phase, 50/60Hz, 34 A max. |
| (2) Reserve Source:                      | 24 VDC, 50 A max.                    |

## 3. ENVIRONMENTAL CONDITION

- |                         |                 |
|-------------------------|-----------------|
| (1) Ambient Temperature |                 |
| Above deck equipment:   | -35°C to +55°C  |
| Below deck equipment:   | -15°C to +55°C  |
| (2) Relative Humidity:  | 93% at +40°C    |
| (3) Vibration           | IEC 60945       |
| (4) Waterproof          |                 |
| Above deck equipment:   | IEC 60945: IPX5 |
| Below deck equipment:   | IEC 60945: IPX2 |

## 4. COATING COLOR

- |                  |                               |
|------------------|-------------------------------|
| (1) Cabinet:     | Munsell 7.5BG7/2              |
| (2) Front Panel: | Munsell N3.0                  |
| (3) Unit Panel:  | See respective specifications |

# SPECIFICATIONS OF THE SSB RADIOTELEPHONE FS-1562-25

## 1. GENERAL

- (1) Communication System                      Simplex or semi-duplex
- (2) Frequency Range                            Transmit: 1.6 MHz to 26.175 MHz (100 Hz steps)  
Receive: 0.1 MHz to 30.0 MHz (10 Hz steps)
- (3) Class of Emission                         J3E, J3C (for intership facsimile),  
H2B, H3E (AM compatible), A3E (reception only)  
F1B = J2B (for DSC, NBDP terminal),  
F3C (for weather facsimile, reception only)
- (4) Number of Channels                        User channel: 200  
ITU SSB/TELEX channels  
2182 kHz (single action)
- (5) Power Supply                                24 VDC: 2 A (reception), 40 A (transmission) max.

## 2. TRANSMITTER

- (1) Frequency Range                            1.6 MHz to 27.5 MHz (100Hz steps)
- (2) RF Output Power                           75/100/200 W<sub>pep</sub> (1.6 to 4 MHz)  
250 W<sub>pep</sub> (4 to 27.5 MHz)
- (3) Power Reduction                           60 W
- (4) Frequency Deviation                       ±10 Hz
- (5) Modulation AF Response                 350 Hz to 2700 Hz within 6 dB
- (6) AF Input                                     -46 dBm/600 ohms
- (7) Line Input                                   0 dBm/600 ohms
- (8) Tone Frequency                            1500 Hz

## 3. RECEIVER

- (1) Receiving System                          Double-conversion superheterodyne
- (2) Frequency Range                           10 kHz 29.99999 MHz (10 Hz steps)
- (3) Sensitivity                                 Input level to produce SINAD 20dB, Unit: dB $\mu$ V

Frequency Range (MHz)	J3E	H3E	F1B
0.1 to 0.3	+40	+54	
0.3 to 1.6	+25	+39	
1.6 to 4	+16	+30	+6
4 to 30	+3		-7

- (4) Selectivity                                 0.1 to 4 MHz: at 10 ohms + 250 pF, 4 to 30 MHz: at 50 ohms  
J3E: 2.4 kHz at -6 dB  
H3E: 0.6 kHz at -6 dB  
F1B: 0.3 kHz at -6 dB
- (5) Spurious Response                        Better than 70 dB
- (6) Intermodulation                            Better than 80 dB
- (7) Audio Output                               Internal speaker: 1 W/ 8 ohms



- (8) Standard Features      Line output: 0 dBm/ 600 ohms  
Scan, Sweep, Noise Blanker, Voice-activated Squelch

#### 4. ANTENNA COUPLER

- (1) Tuning System      CPU controlled fully automatic tuning system  
(2) Frequency Range      1.6 MHz to 27.5 MHz  
(3) Input Impedance      50 ohms (viewed from transceiver)  
(4) Antenna      7 m to 30 m wire or whip antenna + wire  
(5) Required Power Capability      250 W<sub>pep</sub>  
(6) Tuning Power      10 W  
(7) VSWR      1.5 max  
(8) Tuning Time      within 2 to 15 seconds.  
(9) Dummy Load      10 ohms + 250 pF mounted in the coupler  
(10) Power Source      15 VDC: 0.8 A supplied from transceiver unit

#### 5. POWER AMP UNIT

- (1) Input Power      60 W  
(2) Output Power      250 W  
(3) I/O Impedance      50 ohms  
(4) Power Source      24 VDC, 30 A

# SPECIFICATIONS OF FS-5000 SSB RADIOTELEPHONE

## 1. GENERAL

- |                                       |   |
|---------------------------------------|---|
| (1) Communication System              | Full-duplex, semi-duplex or simplex   |
| (2) Class of Emission                 | J3E, A1A, F1B (J2B), J3C  |
| (3) Frequency Range                   | Transmit: 1.6MHz to 30MHz   |
| (4) Number of Channels                | User programmable: 400TX/RX pairs<br>All ITU channels incorporated. (Incl DSC channels) |
| (5) Frequency Accuracy                | ±10Hz (-20°C to 50°C)   |
| (6) Environmental Conditions          |   |
| Ambient Temperature Range             | -20°C to 55°C   |
| Relative Humidity                     | 93% max. (at 40°C)  |
| (7) Power Supply & Power Consumption  | 24VDC +30% to -10%<br>3A (RX)<br>60A (TX power peak)<br>37A (TX power reduced)          |
| (8) Coating Color<br>(not changeable) | Main unit front panel: N3.0<br>Main unit cabinet: 2.5GY5/1.5<br>Antenna Coupler: N9.5   |

## 2. TRANSMITTER

- |                            |  |
|----------------------------|--|
| (1) Frequency Range        | 1.6065 MHz to 29.9999 MHz (100 Hz steps)   |
| (2) RF Output Power        | 400 W <sub>pep</sub> +0/-1.4dB at 50 ohms load (at 24VDC, IEC rec.)<br>Reduction to 60W <sub>pep</sub> or less |
| (3) Modulation AF Response | 350Hz to 2700Hz  |
| (4) Keying Speed           | CW: 25 bauds, TELEX: 100 bauds   |
| (5) AF Input               | -46 dBm/600 ohms   |
| (6) Tone Frequency         | 1500 Hz  |

## 3. RECEIVER

- |                      |  |
|----------------------|--|
| (1) Receiving System | Double-conversion superheterodyne<br>IF: 45455 kHz and 455 kHz |
| (2) Frequency Range  | 10 kHz 29.99999 MHz (10 Hz steps)                              |
| (3) Sensitivity      | Input level at 50ohms to produce SINAD 20dB                    |

Frequency Range	J3E
100kHz to 300kHz	25 dB $\mu$ V
300kHz to 1.6MHz	15 dB $\mu$ V
1.6MHz to 30MHz	3 dB $\mu$ V

- |                      |                                  |
|----------------------|----------------------------------|
| (4) Intermodulation  | 90 dB $\mu$ V (CEPT method test) |
| (5) Cross Modulation | 94 dB $\mu$ V (CEPT method test) |

(6) Selectivity	J3E:	350 to 2700Hz
	A1A/F1B:	±150Hz
(7) Audio Output Power	Internal speaker:	2W/8ohms
	External speaker:	4W/4ohms
	Handset:	10mW/200ohms
(8) Standard Features	Scan, Sweep, Noise Blanker, Voice-activated Squelch, Pre-selector (for MF)	

#### 4. ANTENNA COUPLER

(1) Tuning System	CPU controlled fully automatic tuning system manual tuning possible for 2182kHz	
(2) Frequency Range	1.6MHz to 30MHz	
(3) Input Impedance	50 ohms	
(4) Antenna	7m to 18m wire or whip antenna (For MF band at 400 Wpep output: 8 m whip antenna plus 7 m long wire antenna in parallel)	
(5) Tuning Power	10 W	
(6) VSWR	1.5 max	
(7) Tuning Speed	0.2 to 2 sec. typical 15 sec max.	
(8) Dummy Load	10 ohms + 250 pF mounted in coupler	
(9) Ambient Temperature	-30°C to +70°C	
(10) Relative Humidity	93% max. at 35°C	

## SPECIFICATIONS OF THE DSC/WATCH RECEIVER DSC-60

### 1. DSC TERMINAL

- |                     |   |
|---------------------|---|
| (1) Line out        | 0 dBm (adjustable between -10 dBm and +10 dBm),<br>600 ohms, balanced |
| (2) Line in         | -10 to +10 dBm, 600 ohms, balanced                                    |
| (3) Frequency shift | Mark: 1615 Hz, Space: 1785 Hz   |
| (4) Baud rate       | 100 baud's $\pm 30 \times 10^{-6}$                                    |
| (5) Protocol        | Complies with ITU-R Rec.493-9, 541-8, 1082-1                          |

### 2. GMDSS DSC WATCH KEEPING RECEIVER

- |                            |   |
|----------------------------|---|
| (1) Receiving Frequency    |   |
| For MF spec:               | 2187.5 kHz  |
| For MF/HF spec:            | 2187.5 kHz, 4207.5 kHz, 6312 kHz, 8414.5 kHz,<br>12577 kHz and 16804.5 kHz          |
| (2) Class of Emission      | F1B, J2B  |
| (3) Frequency Stability    | within $\pm 10$ Hz  |
| (4) Intermediate Frequency | 1st: 54455 kHz, 2nd: 455 kHz  |
| (5) Selectivity            | -6 dB: 270 Hz or more<br>-30 dB: within $\pm 380$ Hz<br>-60 dB: within $\pm 550$ Hz |
| (6) RF Input Impedance     | 50 ohms   |
| (7) Receiving Sensitivity  | Better than $0\text{dB}\mu$ (at error rate within 1%)                               |
| (8) Warming-up Time        | 1 minute (oven 30 minutes)  |

### 3. GENERAL WATCH KEEPING RECEIVER (OPTION)

- |                            |   |
|----------------------------|---|
| (1) Receiving Frequency    | 1.6 MHz to 27.5   |
| (2) Class of Emission      | F1B, J2B  |
| (3) Frequency Stability    | within $\pm 10$ Hz  |
| (4) Intermediate Frequency | 1st: 54455 kHz, 2nd: 455 kHz  |
| (5) Selectivity:           | -6 dB: 270 to 300Hz<br>-30 dB: within $\pm 380$ Hz<br>-60 dB: within $\pm 550$ Hz |
| (6) RF Input Impedance:    | 50 ohms   |
| (7) Receiving Sensitivity: | Better than $0\text{dB}\mu$ (at error rate within 1%)                             |
| (8) Warming-up Time:       | 1 minute (oven 30 minutes)  |

#### 4. MF/HF SSB TRANSCEIVER REMOTE STATION

- (1) Line out: 0 dBm, 600 ohms, balanced
- (2) Line in: 0 dBm, 600 ohms, balanced
- (3) AF input (Microphone): -46 dBm, 600 ohms, unbalanced
- (4) AF output (Loudspeaker): 3 W, 4 ohms  
(Handset): 1 mW, 200 ohms

#### 5. DISPLAY

- (1) LCD Unit: 120 x 64 dots
- (2) Characters 20 characters x 8 lines (1 character: 5 x 7 dot) max.  
20 characters x 10 lines (1 character: 5 x 5 dot) max.
- (3) Back Light: Yellow, 8 tones
- (4) Contrast: 64 tones

#### 6. I/O DATA

- (1) Nav. Data input: IEC 61162-1, current loop; 1 pair/port
- (2) DMC: IEC 61162-1/RS232C or  
DMC OUT/IN/CTR H/C; 3 pairs/port
- (3) Received Call output: RCV BZ OUT/IN/CTR; 3 pairs/port
- (4) NBDP: IEC 61162-1/RS232C
- (5) Printer: Centronics (parallel)
- (6) RT (MF/HF Transceiver): IEC 61162-1/RS232C,  
Line in: 0dBm, 600 ohms,  
Line out: 0dBm, 600 ohms,  
and other control signals
- (7) Power Supply 24 VDC (backed up by battery), less than 24 W
- (8) Color Panel: N3.0 (not changeable)

## SPECIFICATIONS OF THE NBDP TERMINAL DP-6

### 1. COMMUNICATIONS

(1) Communication Mode	ARQ, FEC, DIRC (FSK)
(2) Communication Protocol	ITU-R Rec. 625, 476-3, 490, 491, 492
(3) ID Code	4 units, 5 units and 9 units
(4) Line Code	4B/3Y fixed mark (International)
(5) Modulation	AFSK
(6) Tone Frequency (mark/space)	1615/1785 Hz, 1415/1585 Hz 1815/1985 Hz ( $\pm 0.5$ Hz)
(7) Tone Frequency	Tracking Range: 80Hz
(8) Line Input/ Output	0 dBm (-30 dBm to +10 dBm, 600 ohms balanced)

### 2. COMMUNICATION FEATURES

(1) Automatic transmission	Timer Programming Automatic transmission and receiving (maximum 10 stations)
(2) Scramble operation	Maximum 5 different code sets
(3) Frequency scanning	maximum 10 groups, 20 channels/group
(4) Morse code conversion	Transmit only
(5) Storage channels	Storage for up to 100 user channels
(6) Application to MARITEX.	Available

### 3. TERMINAL UNIT (IB-581)

(1) Display	Monochrome 9.5" LCD, 80 x 25 characters (7 x 9 dots)
(2) Microprocessor	intel 80386SX 40 MHz
(3) Memory	Flash EPROM and 1 MB RAM
(4) Disk Drive	720kB or 1.44kB 3.5" FDD
(5) Keyboard	enhanced 82-key keyboard emulates the IBM PS/2 keyboard and includes embedded numeric and cursor control overlay and dedicated cursor control keys.
(6) Other Features	Text editing screen, Floppy disk management, Nav data input and display, Remote control of transceiver, Self-diagnosis
(7) Power Supply	
Main Unit:	24 VDC: 0.9 A
Terminal Unit:	24 VDC: 0.8 A

# SPECIFICATIONS OF THE INMARSAT MES FELCOM 12

## 1. GENERAL

(1) Transmitting Frequency	1626.5 to 1646.5 MHz
(2) Receiving Frequency	1530.0 to 1545.0 MHz
(3) Antenna	Omnidirectional
(4) G/T	Better than -23 dBW (elevation angle 5°)
(5) EIRP	12 to 16 dBW (elevation angle 5°)
(6) Modulation	BPSK
(7) Modulation Rate	1200 sps
(8) Convolution Coding	coding rate 1/2 and constraint length 7
(9) Decoding	Viterbi decoder
(10) Transmission Speed	600 bps
(11) Navigational data Interface	NMEA0183

## 2. POWER SUPPLY

(1) Antenna/communication Unit	24 VDC: 1.3 A (reception), 7.5 A (transmission)
(2) Terminal Unit	24 VDC, 0.8 A
(3) Printer	24 VDC, 1.4 A

## 3. ENVIRONMENTAL CONDITION

(1) Temperature	Above deck equipment: -35°C to +55°C Below deck equipment: -12°C to +55°C
(2) Relative Humidity	95% (at 40°C)

## 4. COATING COLOR

(1) Antenna unit	radome: N9.5, base: 2.5PB3.5/10
(2) Communication unit	N3.0
(3) Terminal unit	panel: N3.0
(4) Distress alert unit	2.5GY5/1.5
(5) Received call unit	2.5GY5/1.5

## SPECIFICATIONS OF THE PRINTER PP-510

### 1. GENERAL

(1) Printing System	Serial Impact dot matrix
(2) Character Composition	9 x 7 dot matrix
(3) Printing Speed	Draft: 200 characters/second, NLQ: 50 characters/second
(4) Emulation	Epson FX850 mode or IBM Proprinter II mode
(5) Type of Characters	324 letters (Epson FX850 mode) 262 letters (IBM Proprinter II mode)
(6) Type of Paper	Roll paper, type "1P", non-carbon paper 34 g/m <sup>2</sup>
(7) Paper Holder	
Maximum width	209 to 216mm
Maximum diameter	124mm
Internal diameter	25mm (winding core)
Paper end sensor	Provided
(8) Paper Advance Speed	1/6, 1/8 or 1/216 inch steps, 8.3 lines/sec (at 1/6" step)
(9) Data Buffer	21K bytes (Epson FX850 mode) 9.3K bytes (IBM Proprinter II mode)
(10) Number of Copies	Original plus 2 copies (Total thickness: 0.2mm or less)
(11) Ink Ribbon	Original fabric ribbon (13mm x 14m)
(12) Interface	Parallel interface (Centronics)
(13) Noise	Less than 59 dBA

### 2. ENVIRONMENTAL CONDITION

(1) Operating Temperature	5°C to 35°C
(2) Operating Relative Humidity	20% to 85% (non-condensing)

### 3. POWER SUPPLY

(1) Power Consumption	24 VDC: 1.5 A, 36 W max.
-----------------------	--------------------------



## **SPECIFICATIONS OF THE AC/DC CHANGE-OVER UNIT (RADIO SWITCH BOX)**

### **1. BATTERY CHARGER (BC-6158)**

- |                            |   |
|----------------------------|---|
| (1) Applicable Battery     | 200AH Normal ship battery                         |
| (2) Power Source           | 100/110/115/220/230 VAC, 1 phase, 60 Hz or 24 VDC |
| (3) Output for Battery     | 24 VDC, 30 A nominal                              |
| (4) Charge/discharge Meter | built in the radio console panel                  |
| (5) Control Panel          | built in the radio console                        |

### **2. RECTIFIER (PR-850AR)**

- |                           |   |
|---------------------------|---|
| (1) Power Source          | 100/110/200/220 VAC, 1 phase, 50-60 Hz or 24 VDC            |
| (2) Input Current         | 15 A or less (AC input), 30 A or less (DC input)            |
| (3) Rush Current          | 80 A or less  |
| (4) Output Voltage        | DC24 V $\pm$ 10%, 30 A                                      |
| (5) Peak Output Current   | 60 A (60 A output with 1 min AC or 40 A within 1 min DC)    |
| (6) Ripple Voltage        | 100 mVp-p or less   |
| (7) Insulation Resistance | 500 VDC, 50 M $\Omega$ or more between AC input and chassis |

### **3. RECTIFIER (PR-300)**

- |                           |   |
|---------------------------|---|
| (1) Power Source          | 100/110/200/220 VAC, 1 phase, 50-60 Hz or 24 VDC            |
| (2) Input Current         | 2 A or less (AC input), 3.1 A or less (DC input)            |
| (8) Rush Current          | 80 A or less  |
| (3) Output Voltage        | 24 VDC $\pm$ 10%, 7.5 A                                     |
| (4) Peak Output Current   | 20 A (10 A output within 2H or 20 A within 15 min)          |
| (5) Ripple Voltage        | 100 mVp-p or less   |
| (9) Insulation Resistance | 500 VDC, 50 M $\Omega$ or more between AC input and chassis |

